



**ELLIOTT**  
EQUIPMENT COMPANY

# MINEREACH

**TOUGH JOBS CALL FOR TOUGH EQUIPMENT**

Mining is hard work, which is why Elliott's products are built from the ground up with heavy-duty components that are built to last. Whether you are scaling, maintaining or placing explosives, Elliott's MineReach makes your job easier and more efficient than ever before, with its combination of a high capacity, multi-featured work platform, ANFO delivery system, and material handling capabilities on a single machine. Elliott's "Office In The Sky" accessory options bring your tools to the platform, where the work is performed, making you more efficient on the job.

*Every Elliott comes standard with the peace of mind of knowing that your investment is backed by the best warranty in the industry.*



## BUILT FOR YOU

We know that every job is different and requires unique solutions to get the job done right. Starting with a wide range of optional equipment, Elliott's distributors and engineers will work with you to build exactly what you need to do your job, your way.

BUILT FOR YOU

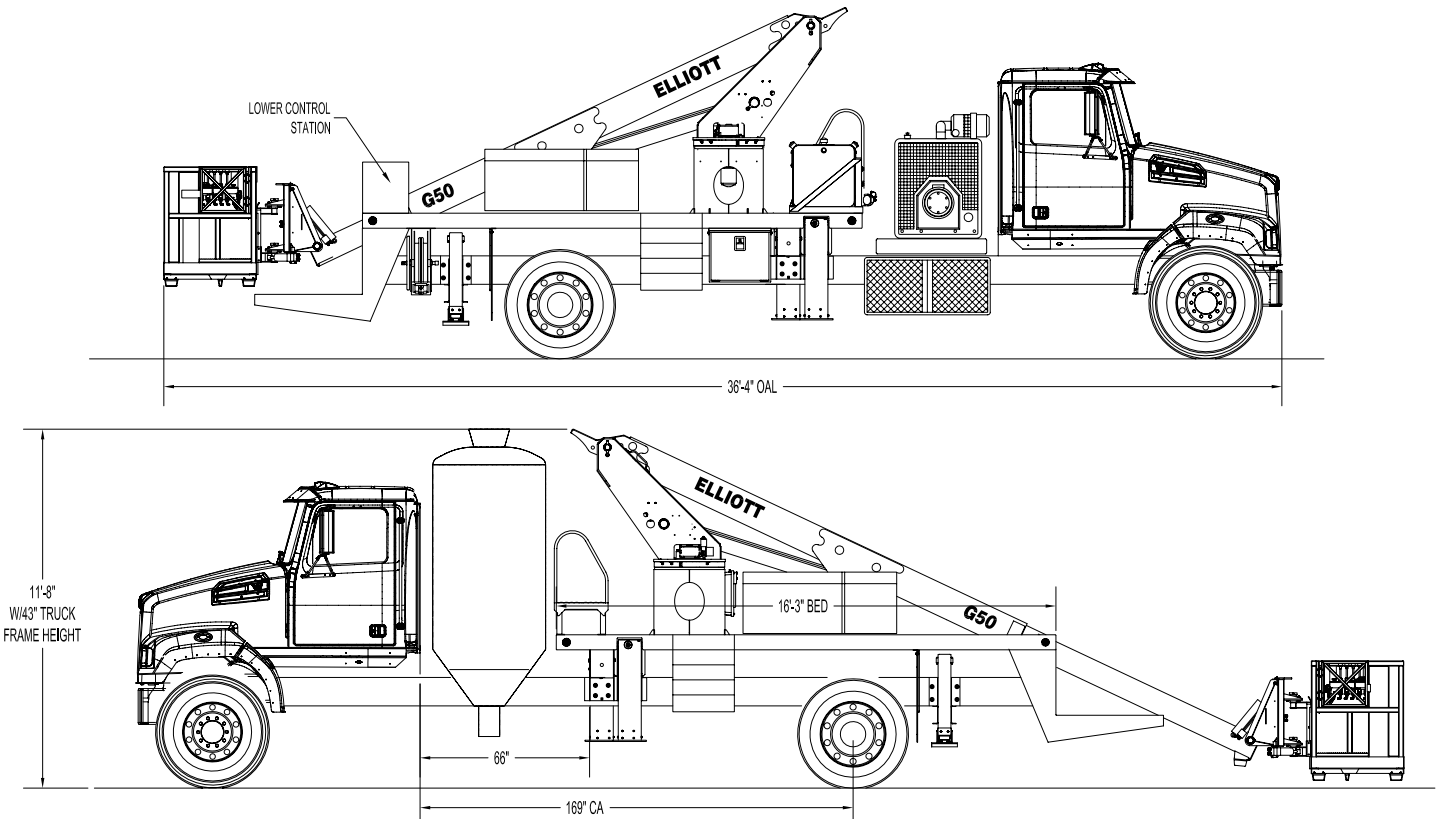

## STANDARD MINEREACH FEATURES

- Choose a 45 foot working height (G40F) or 55 foot working height (G50F)
- 40"x60" EZR platform with reinforced rails
- ANFO lines routed to platform through cable carrier
- 350 degree boom rotation
- 600 pound platform capacity
- Stainless steel platform floor
- Pilot pressure hydraulic upper controls with mine environment filter and heater
- Bed height lower controls for easy access
- Steel, aluminum or wood floor bed with integrated walk up steps
- Extra wide dropped rear tail shelf and work surface
- ANFO tanks installed behind cab
- "A" type hydraulically controlled outriggers (front and rear)
- ANFO tanks powered by hydraulic driven air compressor
- Walkway access to load ANFO pots
- 12 volt emergency pump with switch at upper and lower controls

## OPTIONAL MINEREACH FEATURES

- MineReach unit can be operated by PTO or secondary diesel engine
- 5,900 lb capacity main boom winch
- 1,000 lb capacity jib winch at platform
- Radio remote controls
- Out and down hydraulically controlled outriggers
- 40"x72" or 36"x96" oversized work platform
- Covered work platform
- 110v outlet at platform
- Air lines to platform
- Welding leads to platform
- ANFO lines can be externally routed
- Hydraulic oil cooler
- Various LED work light options mounted to turret, boom and platform
- Various LED strobe light options
- Multiple toolbox and day box sizes
- DuraBull extreme protective coating on platform, bed, boxes for corrosion resistance