

**ELLIOTT**  
EQUIPMENT COMPANY

BOOMTRUCKS  
**26-36 TON CAPACITY**

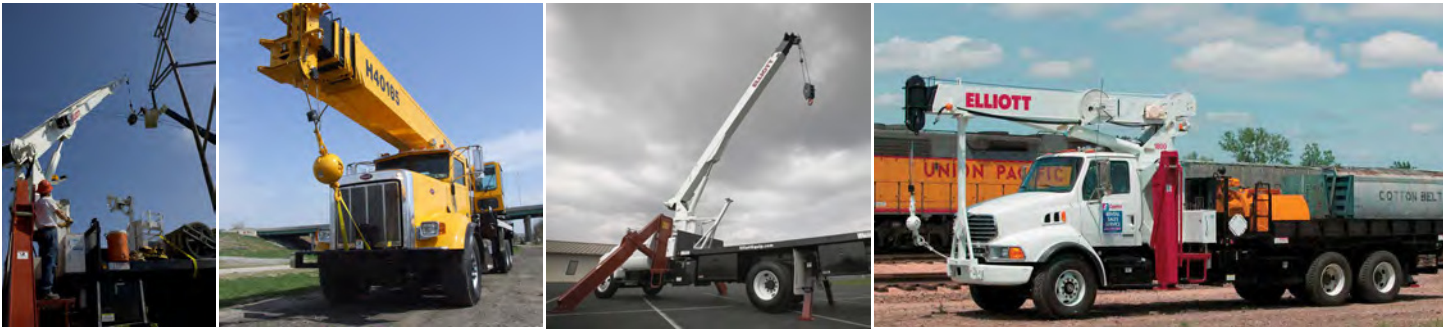



### 2651F SIDE VIEW DIAGRAM

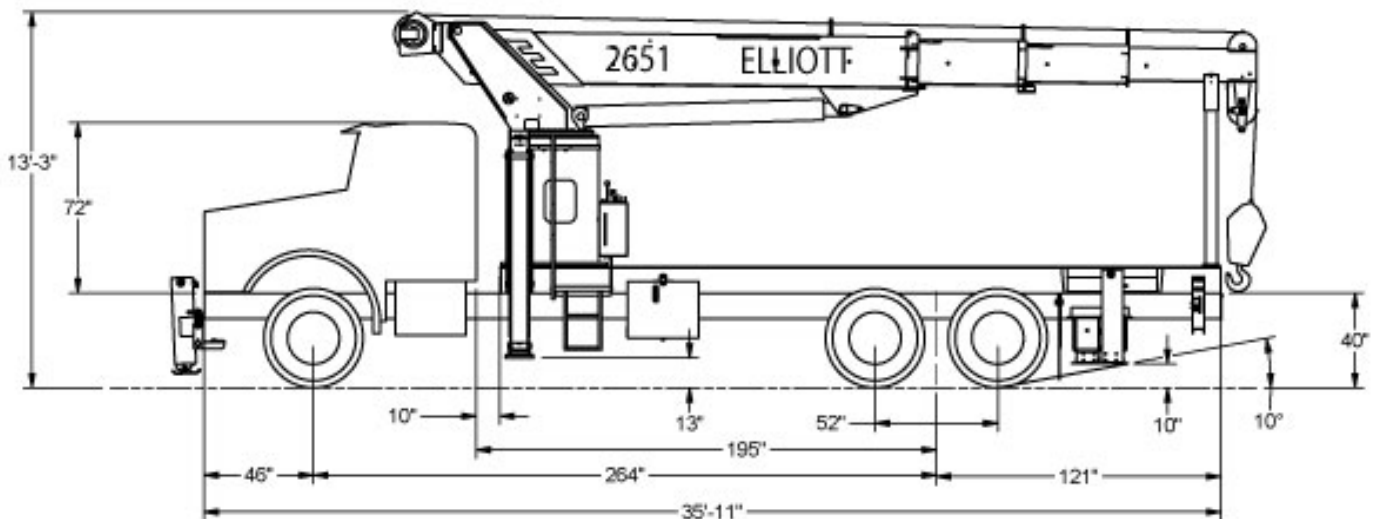

- |                                  |                      |                                  |                               |
|----------------------------------|----------------------|----------------------------------|-------------------------------|
| • <b>Maximum Vertical Reach</b>  | 61'18,6 m            | • <b>Powered Boom Sections</b>   | 4                             |
| • <b>Working Area</b>            | 360 Degrees          | • <b>Overall Height (42" FH)</b> | 13'5"/4 m                     |
| • <b>Lifting Capacity</b>        | 52,000 lbs/23 587 kg | • <b>Operator Controls</b>       | Dual Operator Standup Console |
| • <b>Boom Length</b>             | 51'15,5 m            | • <b>Outrigger Type Front</b>    | "A" Frame                     |
| • <b>Crane Weight (Standard)</b> | 22,000 lbs/9979 kg   | • <b>Outrigger Spread Front</b>  | 20'8"/6,3 m                   |
| • <b>Jib Lengths</b>             | N/A                  | • <b>Outrigger Type Rear</b>     | Out-Down                      |
| • <b>Winch Bare Drum Pull</b>    | 12,800 lbs/5806 kg   | • <b>Outrigger Spread Rear</b>   | 18'2"/5,5 m                   |

## TECHNICAL SPECIFICATIONS

**Crane Capacity:** 52,000 lbs at 5' load radius.

**Maximum Tip Height:** 61' height.

**Control Console:** Dual standup operator control stations with Dynasmooth controls, pressure gauge, LMI display, bubble level gauge, engine start/stop switch, signal horn button, variable speed foot throttle, lifting capacity chart, range diagram chart, boom angle indicator, system pressure gauge, 12V DC power source, and cup holder. Outrigger lever controls at control consoles.

**Boom:** Four-section fully proportional, high strength steel plated rectangular tube sections. A maximum boom tip height of 61'. The boom nose contains one floating upper sheave and three lower sheaves. Assembly includes heavy-duty cylinder fittings, pivot pins, and replaceable wear pads.

**Winch:** Mounted at the base of the boom for a long fleet angle and flat level spooling of cable. Winch is driven by a planetary reducer and powered by a hydraulic motor. Burst-of-speed winch provides increased line speed. The winch brake is spring applied, pressure release design. Supplied with 425' of 9/16" diameter rotation resistant wire rope with a single line pull of 9,060 pounds, and a downhaul ball with swivel hook for single part line.

**Load Moment Indicator System:**

System senses hoist cylinder pressures, boom length and boom angle with hydraulic function lockout. The display console is equipped with a bar graph showing crane utilization, boom angle or boom length, a mode select controls for main boom and jib operation, and an anti-two block with an audio/visual warning and shut-off functions to limit hook-boom point contact.

**Outriggers:** One set of 'A' Frame front outriggers with 20'10" span and one set of out and down underslung rear

outriggers with 18'2" span. Outriggers are configured for full span operation.

**Frame:** 4-plate design sub-frame inside track tub. Sub-frame allows for bolt-on addition of steel diamond plated bed with stake pockets.

**Turret:** Reverse offset turret is one-piece weldment. Turret rotates on large diameter ball bearing.

**Rotation:** Hydraulic motor drives turret through double reduction planetary swing drive for 372 degree non-continuous rotation. The swing drive system has a spring applied, pressure release brake.

**Lift:** One double-acting long stroke cylinder provides smooth and stable boom elevation. Holding valve prevent boom from falling in event of hose failure.

**Boom Extension:** Incorporates a 2-stage hydraulic extension cylinder, attached to the largest boom section, with a proportional cable extension system driving the outermost sections.

**Hoses:** All high pressure hoses are wire braid reinforced with a minimum safety factor of 4 to 1.

**Cylinders:** All cylinders use microhoned cylinder tubing, chrome shafts, top grade packing and protective rod wipers. Cylinder-mounted holding valves provided on all load-holding cylinders.

**Hydraulic System:** Equipped with three-section gear pump, SAE O-ring face seals on pressure lines, and a 10-micron return line filter. The control valve distributes all flow to hoist system, swing circuit, and other crane functions. System is open center type.

**Oil Tank Capacity:** 120 gallon mounted on side of truck frame.

**Cab Equipment:** U/L approved 5:BC dry chemical fire extinguisher installed in truck cab.

**Operators Manual & Video:** Two CD copies and one hard copy of operation, maintenance, safety and parts manual provided with each unit. Operational and safety video provided at delivery.

**Installation:** Unit installed on truck chassis, painted, system and tank filled with oil, tested, inspected, and ready to operate.

**Standard Paint:** Paint turret and boom white, outriggers red, and bed and boxes black.

**Weight:** Approximately 22,000 lbs. (crane only).

**Chassis Required:** 60,000 lb GVWR capacity, 12V electrical system with high capacity alternator. Contact factory for complete specification review.

**Options:**

Continuous Rotation.

Shortjacking With Superlink Outriggers.

18' Steel or Wood Bed.

Two-Person Gravity Leveled Work Platform.

Custom Toolboxes.

Hydraulic Tool Circuits on Bed.

Removable Boom Rest.

Front Recovery Winch.

Much more...

Elliott Equipment Company reserves the right to change the specification of any unit at any time without prior notice. This brochure is only a statement of general specifications on the date of this publication. For more detailed info on specific Elliott trucks go to [www.elliottequip.com](http://www.elliottequip.com)

**LOAD CHART - MAIN BOOM, FULL-SPAN OUTRIGGERS**

**MAIN BOOM LOAD RATINGS**

LOAD RATINGS IN LBS. WITH OUTRIGGERS AND STABILIZERS EXTENDED





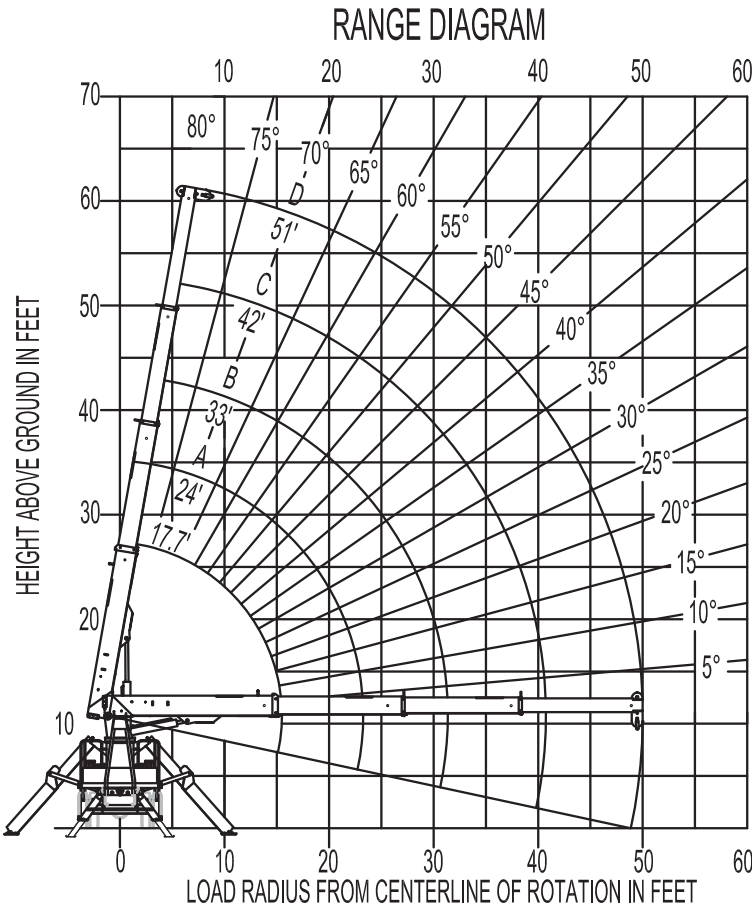

LOAD RADIUS IN FEET	LOADED BOOM ANGLE	17.7-ft	LOADED BOOM ANGLE	A 24-ft	LOADED BOOM ANGLE	B 33-ft	LOADED BOOM ANGLE	C 42-ft	LOADED BOOM ANGLE	D 51-ft
5	70.9	52,000								
8	59.6	35,000	68.6	31,000						
10	51.4	30,300	63.2	27,200	71.2	24,000	75.6	23,000	78.3	21,000
12	42	26,000	57.5	23,300	67.4	21,000	72.7	20,000	75.9	18,900
14	30.2	22,100	51.3	21,000	63.5	18,700	69.7	17,600	73.5	16,200
16			44.5	18,800	59.4	17,000	66.7	15,700	71.1	14,800
18			36.9	17,000	55.1	15,500	63.6	14,000	69.2	13,000
20			27.4	15,000	51.6	15,500	61.2	13,000	66.7	12,650
25					38.9	11,000	52.8	10,600	60.2	10,300
30					20.3	8,600	43.3	8,700	53.3	8,600
35							31.6	7,000	45.8	7,300
40							12.2	5,000	37	6,100
45									25.8	4,600
	0	10,000	0	6,150	0	3,800	0	3,500	0	2,800

**RANGE CHART - MAIN BOOM, FULL-SPAN OUTRIGGERS**

**ELLIOTT** MODEL 2600 51-FT. BOOM  
EQUIPMENT COMPANY



**ALLOWABLE LINE PULL**

1-PART LINE	2-PART LINE	3-PART LINE	4-PART LINE	5-PART LINE	6-PART LINE	NOTICE
						<ul style="list-style-type: none"> <li>- DO NOT DEADHEAD LINE BLOCK AGAINST BOOM TIP WHEN EXTENDING BOOM.</li> <li>- KEEP AT LEAST 5 WRAPS OF LOADLINE ON THE WINCH DRUM AT ALL TIMES.</li> <li>- USE ONLY 9/16" DIAMETER WIRE ROPE, AS SPECIFIED BELOW, WITH THE PROPER BREAKING STRENGTHS LISTED.</li> <li>- ANTI-TWO-BLOCK SYSTEM MUST BE IN GOOD OPERATING CONDITION BEFORE OPERATING CRANE. SEE OPERATOR'S SAFETY MANUAL.</li> <li>- MAXIMUM CAPACITY WITH "BURST OF SPEED" IS 500 LBS.</li> </ul>
MAX PULL: 9,600 lbs	19,200 lbs	28,800 lbs	38,400 lbs	48,000 lbs	52,000 lbs	9/16" -6 x 37 IWRC (3.5:1 S.F.) 33,600-lbs BREAKING STRENGTH
MAX PULL: 9,060 lbs	18,120 lbs	27,180 lbs	36,240 lbs	45,300 lbs	52,000 lbs	9/16" -SPIN RESISTANT (5:1 S.F.) 45,300-lbs BREAKING STRENGTH

DEDUCTIONS FROM RATED LOADS FOR HANDLING DEVICES SUPPLIED BY ELLIOTT EQUIPMENT CO,  
OVERHAUL BALL -----SEE OVERHAUL BALL MFGR. NAMEPLATE  
LOAD BLOCK -----SEE BLOCK MFGR. NAMEPLATE  
SWING AROUND JIB -----SEE LOAD RATING CHART

## CHASSIS SPECIFICATIONS

	2651F BoomTruck
Wheelbase (WB)	256" / 650 cm
Cab to Tandem (CT)	192" / 488 cm
Cab to End of Frame (EOF)	390" / 792 cm
Frame Section Modulus	15.9 in3-110,000 psi / 758,428 kPa
Front Axle Gross Weight Rating	20,000 lb / 9071 kg
Rear Axle Gross Weight Rating	40,000 lb / 18 143 kg
Integral Front Frame Rails	Required for Front Stabilizer

Chassis data is minimum general requirements-not for engineering.  
 Actual dimensions and truck data will depend on truck selection and axle configuration.  
 \*Minimum chassis weight is required to meet 85% stability requirements.

## OPTIONS



### Radio Remote Control

Interference protected radio remotes let you get closer to your work and have full control over your machine. Includes optional LMI screen.

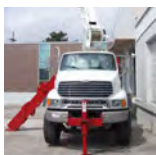

### Superlink Short Jack Outriggers

Reduce your outrigger spread with Elliott's patented Superlink outriggers that allow straight down outrigger deployment on one side and unrestricted lifting on the other.



### Continuous Boom Rotation

Add the convenience of 360 degree area of operation by adding a front stabilizer and continuous rotation mechanism.



### Hydraulic Oil Cooler

Add a bed-mounted hydraulic oil cooler to assist with high duty cycle job applications.



### Tool Boxes

Optional tool boxes and bed storage can accommodate any storage need for tools, work materials and more.

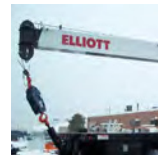

### Hook Block for Multi-Part Line

Elliott can install a 2-3 part hook block or a 4 part-hook block to improve lifting capabilities. The block can be stored at the rear of the bed.



### Gravity Levelled Basket

Elliott's pin-on work platform pins onto the boom for easy installation and removal. Gravity leveling and mechanical rotation makes it a great accessory for any worksite.

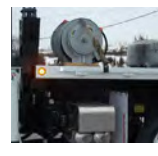

### Body Mounted Hose Reels and Circuits

Let us work with you to customize your tool compatability by adding hose reels or hydraulic circuits to the crane bed.

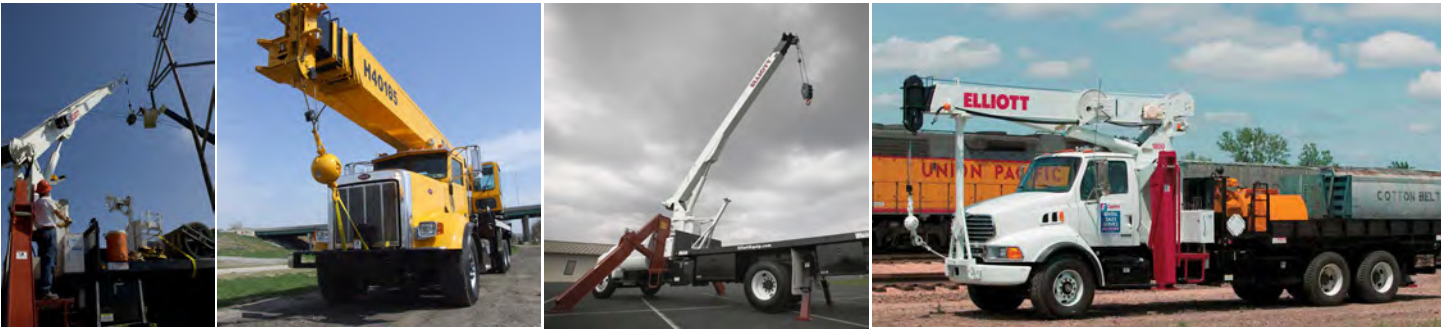

### 2695F SIDE VIEW DIAGRAM

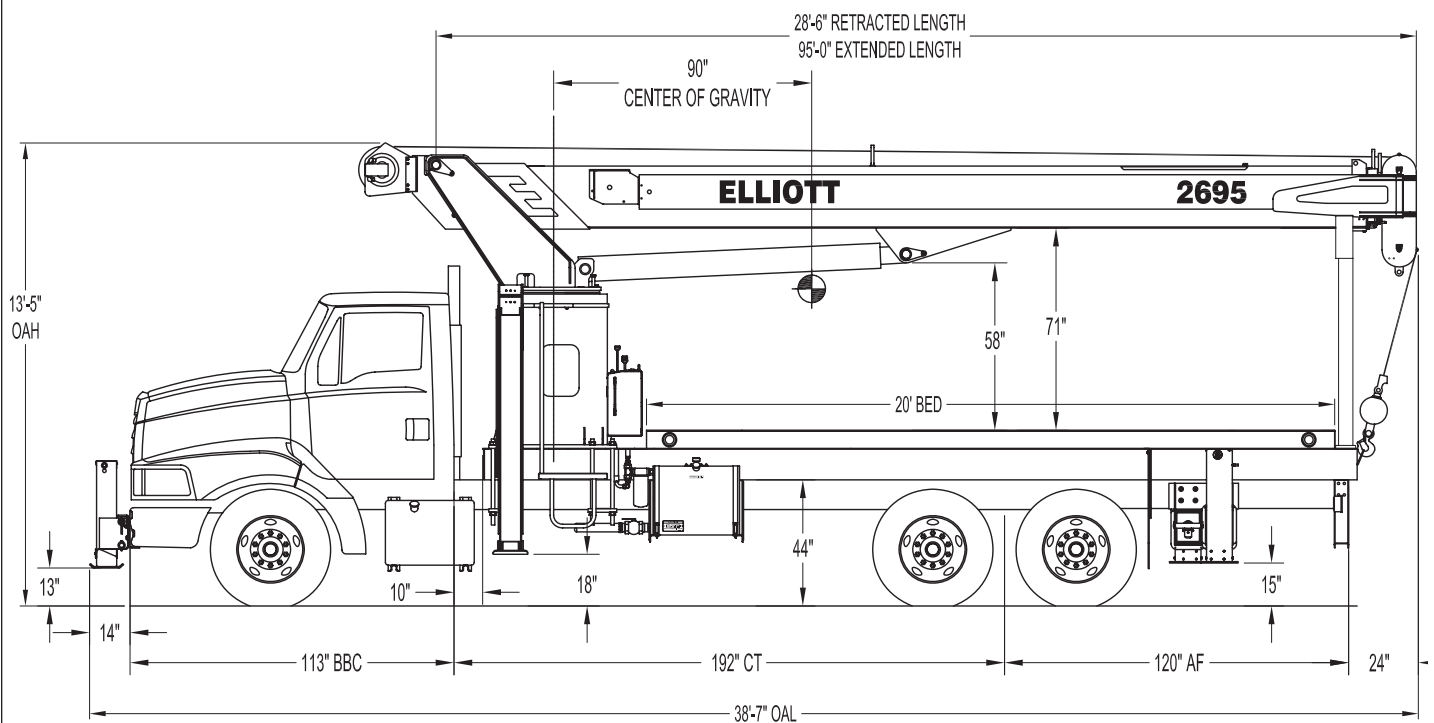

- |                                 |                                     |                                 |                       |
|---------------------------------|-------------------------------------|---------------------------------|-----------------------|
| • <b>Maximum Vertical Reach</b> | 152' / 46,3 m                       | • <b>Powered Boom Sections</b>  | 4                     |
| • <b>Working Area</b>           | 180 Degrees Standard (360 Optional) | • <b>Overall Height</b>         | 13'5" / 4,1 m         |
| • <b>Lifting Capacity</b>       | 52,000 lbs / 23 587 kg              | • <b>Operator Controls</b>      | Dual Operator Standup |
| • <b>Boom Length</b>            | 95' / 29 m                          | • <b>Outrigger Type Front</b>   | A-Frame               |
| • <b>Crane Weight (Dry)</b>     | 24,920 lbs / 11 303 kg              | • <b>Outrigger Spread Front</b> | 20'10" / 6,3 m        |
| • <b>Jib Length</b>             | 26', 26'-45' / 8 m, 8-13,7 m        | • <b>Outrigger Type Rear</b>    | Out-Down              |
| • <b>Winch Bare Drum Pull</b>   | 12,800 lbs / 5806 kg                | • <b>Outrigger Spread Rear</b>  | 18'2" / 5,5 m         |

## TECHNICAL SPECIFICATIONS

**Crane Capacity:** 52,000 lbs at 5' load radius.

**Maximum Tip Height:** 107' height (152' with optional 45' jib)

**Control Console:** Dual operator standup control stations equipped with four single axis control levers for the main crane controls. Operator station includes LMI display, bubble level gauge, engine start/stop switch, signal horn button, variable speed throttle switch, lifting capacity chart, range diagram chart, boom angle indicator, system pressure gauge, 12V DC power source, and cup holder. Outrigger lever controls at control consoles.

**Boom:** Four-section fully proportional, high strength steel plated rectangular tube sections. A maximum boom tip height of 107' mounted on a truck. The boom nose contains one floating upper sheave and three lower sheaves. Assembly includes heavy-duty cylinder fittings, pivot pins, and replaceable wear pads.

**Winch:** Mounted at the base of the boom for a long fleet angle and flat level spooling of cable. Winch is driven by a planetary reducer and powered by a hydraulic motor. Burst-of-speed winch provides increased line speed. The winch brake is spring applied, pressure release design. Supplied with 425' of 9/16" diameter rotation resistant wire rope with a single line pull of 9,060 pounds, and a downhaul ball with swivel hook for single part line.

**Load Moment Indicator System:**

System senses hoist cylinder pressures, boom length and boom angle with hydraulic function lockout. The display console is equipped with a bar graph showing crane utilization, boom angle or boom length, a mode select controls for main boom and jib operation, and an anti-two block with an audio/visual warning and shut-off functions to limit hook-boom point contact.

**Outriggers:** One sets of "A" Frame main outriggers with 20'10" span, and one set of out and down underslung auxiliary outriggers with 18'2" span.

**Frame:** Full length, all welded rigid 4-plate design sub-frame. Sub-frame allows for bolt-on addition of 20' bed.

**Turret:** Reverse offset turret is one-piece weldment. Turret rotates on large diameter ball bearing.

**Rotation:** Hydraulic motor drives turret through double reduction planetary swing drive for 372-degree non-continuous rotation. The swing drive system has a spring applied, pressure release brake.

**Lift:** One double-acting long stroke cylinder provides smooth and stable boom elevation. Holding valve prevents boom from falling in event of hose failure.

**Boom Extension:** Incorporates a 2-stage hydraulic extension cylinder, attached to the largest boom section, with a proportional cable extension system driving the outermost sections.

**Hoses:** All high pressure hoses are wire braid reinforced with a minimum safety factor of 4 to 1.

**Cylinders:** All cylinders use microhoned cylinder tubing, chrome shafts, top grade packing and protective rod wipers. Cylinder-mounted holding valves provided on all load-holding cylinders.

**Hydraulic System:** Equipped with cable-shift PTO, gear pump, SAE O-ring face seals on pressure lines, and a 10-micron return line filter. The control valve distributes all flow to hoist system, swing circuit, and other crane functions. System is open center type.

**Oil Tank Capacity:** 120 gallon mounted to truck frame on roadside.

**Cab Equipment:** PTO cable with indicator lights installed in truck cab. U/L approved 5:BC dry chemical fire extinguisher installed in truck cab.

**Operators Manual & Video:** Two CD copies and one hard copy of operation, maintenance, safety and parts manual provided with each unit. Operational and safety video provided at delivery.

**Installation:** Unit installed on chassis, painted, system and tank filled with oil, tested, inspected, and ready to operate.

**Standard Paint:** Paint turret and boom white, outriggers red, and bed and boxes black.

**Bumper:** Bureau of Motor Carrier Safety rear bumper.

**Weight:** Approximately 24,920 lbs. with 20' steel-floor bed less truck.

**Truck Chassis Required:** Approx. 192" C.A. RBM 1,749,000 in-lb. per rail, 20,000 lb. front axle and 40,000 lb. GVWR required. Trucks must have front frame extension, 12V electrical system with high capacity alternator, cab clearance stop/tail/backup lights, and I.D. lamps. Recommended GVWR is minimum for BOOMTRUCK with flatbed only. Contact factory when additional equipment is to be added.

**Options:**

26'-45' Telescopic Pin-on Jib.

Radio Remote Controls.

Superlink Shortjack Outriggers.

Gravity Leveled Steel Work Platform.

Front Jack for 360 Degree Area of Operation.

Hydraulic Tool Circuits on Bed.

Much More...

Elliott Equipment Company reserves the right to change the specification of any unit at any time without prior notice. This brochure is only a statement of general specifications on the date of this publication. For more detailed info on specific Elliott trucks go to [www.elliottequip.com](http://www.elliottequip.com)

**LOAD CHART - MAIN BOOM, FULL-SPAN OUTRIGGERS**

**MAIN BOOM LOAD RATINGS WITH FULLY EXTENDED OUTRIGGERS**

LOAD RADIUS IN FEET	LOADED BOOM ANGLE	28-FT.	LOADED BOOM ANGLE	A 43-FT.	LOADED BOOM ANGLE	B 56-FT.	LOADED BOOM ANGLE	C 69-FT.	LOADED BOOM ANGLE	D 82-FT.	LOADED BOOM ANGLE	E 95-FT.
5	78.5	52,000										
8	72	41,600	79	30,700								
10	67	35,100	76	30,500	80	24,000						
12	62.5	30,400	73.5	26,300	78	21,000						
14	57	26,500	70.5	23,200	75.5	18,700	79	19,000				
16	51.5	22,600	67.5	20,500	73.5	15,300	77.5	17,000	80	14,500		
20	39	18,300	61	18,000	69	12,400	74	13,900	77	12,500	79	10,200
25	11.5	13,000	52.5	13,700	63	10,400	69.5	11,100	73.5	10,500	76.5	9,100
30			42.5	10,700	57.5	8,800	65	9,650	70	9,000	73.5	8,100
35			31	8,700	50.5	7,250	60	8,250	66	7,550	70	7,050
40					43	6,050	55	7,150	62	6,650	66.5	6,150
45					34	4,900	49.5	6,000	57.5	5,700	63	5,350
50					21	3,750	43	4,950	53	4,700	59.5	4,650
55							35.5	4,100	48	4,050	56	4,050
60							26.5	3,350	43	3,400	51.5	3,450
65							11	2,650	37	2,850	47.5	2,850
70									30	2,350	42.5	2,350
75									20.5	1,950	37.5	1,950
80											31.5	1,550
85											24	950
	0	6,000	0	3,000	0	1,000	0	500				
DEDUCTIONS FOR STOWED JIB (lbs)	900		600		450		350		300		250	
	600		400		300		250		200		200	

**JIB LOAD RATINGS WITH FULLY EXTENDED OUTRIGGERS**

26-ft FIXED LENGTH JIB			26'-45' TWO SECTION JIB					
LOAD RADIUS IN FEET	LOADED BOOM ANGLE	26-ft JIB	RETRACTED 26' JIB		EXTENDED 45' JIB			
			LOAD RADIUS IN FEET	LOADED BOOM ANGLE	26-ft JIB	LOAD RADIUS IN FEET	LOADED BOOM ANGLE	45-ft JIB
25	77	5,550	25	77	5,300	25	79	3,000
30	74.5	4,750	30	74.5	4,500	30	77	2,800
35	72	4,250	35	72	4,000	35	74.5	2,550
40	69.5	3,750	40	69.5	3,500	40	72.5	2,300
45	66.5	3,150	45	66.5	2,900	45	70.5	2,050
50	64	2,700	50	64	2,450	50	68	1,900
55	61.5	2,150	55	61.5	1,900	55	66	1,650
60	58.5	1,900	60	58.5	1,550	60	63.5	1,400
65	55.5	1,600	65	55.5	1,350	65	61.5	1,100
70	52.5	1,400	70	52.5	1,150	70	59	1,000
75	49.5	1,050	75	49.5	800	75	56.5	800
80	46	850	80	46	600	80	54	600

**NOTICE**

- DO NOT DEADHEAD LINE BLOCK AGAINST BOOM TIP WHEN EXTENDING BOOM.
- KEEP AT LEAST 5 WRAPS OF LOADLINE ON THE WINCH DRUM AT ALL TIMES.
- USE ONLY 9/16" DIAMETER WIRE ROPE, AS SPECIFIED BELOW, WITH THE PROPER BREAKING STRENGTHS LISTED.
- ANTI-TWO-BLOCK SYSTEM MUST BE IN GOOD OPERATING CONDITION BEFORE OPERATING CRANE. SEE OPERATION & SAFETY MANUAL.

DEDUCTIONS FOR STOWED EXTENDABLE JIB (lbs)

DEDUCTIONS FOR STOWED FIXED LENGTH JIB (lbs)

**1-PART LINE**



**2-PART LINE**



**3-PART LINE**



**4-PART LINE**



**5-PART LINE**



**6-PART LINE**



**ELLIOTT EQUIPMENT CO. SUPPLIED LOADLINE EQUIPMENT DEDUCTIONS:**  
 DOWNHAUL WEIGHT .....180 lbs  
 ONE SHEAVE BLOCK.....375 lbs  
 TWO SHEAVE BLOCK.....640 lbs  
 THREE SHEAVE BLOCK.....870 lbs  
 AUXILIARY SHEAVE.....100 lbs

MAX PULL: 9,060 lbs	18,120 lbs	27,180 lbs	36,240 lbs	45,300 lbs	52,000 lbs	9/16" -SPIN RESISTANT 5:1 S.F.) 45,300-lbs. BREAKING STRENGTH
---------------------	------------	------------	------------	------------	------------	--

CRANE MEETS ASME B30.1 REQUIREMENTS AT TIME OF MANUFACTURE

DO NOT PAINT OVER ANY LABELS 111580-07106

**RANGE CHART - MAIN BOOM + JIB, FULL-SPAN OUTRIGGERS**

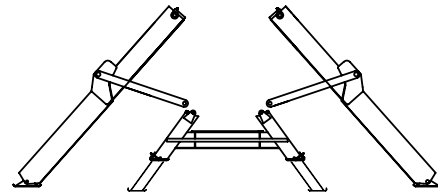
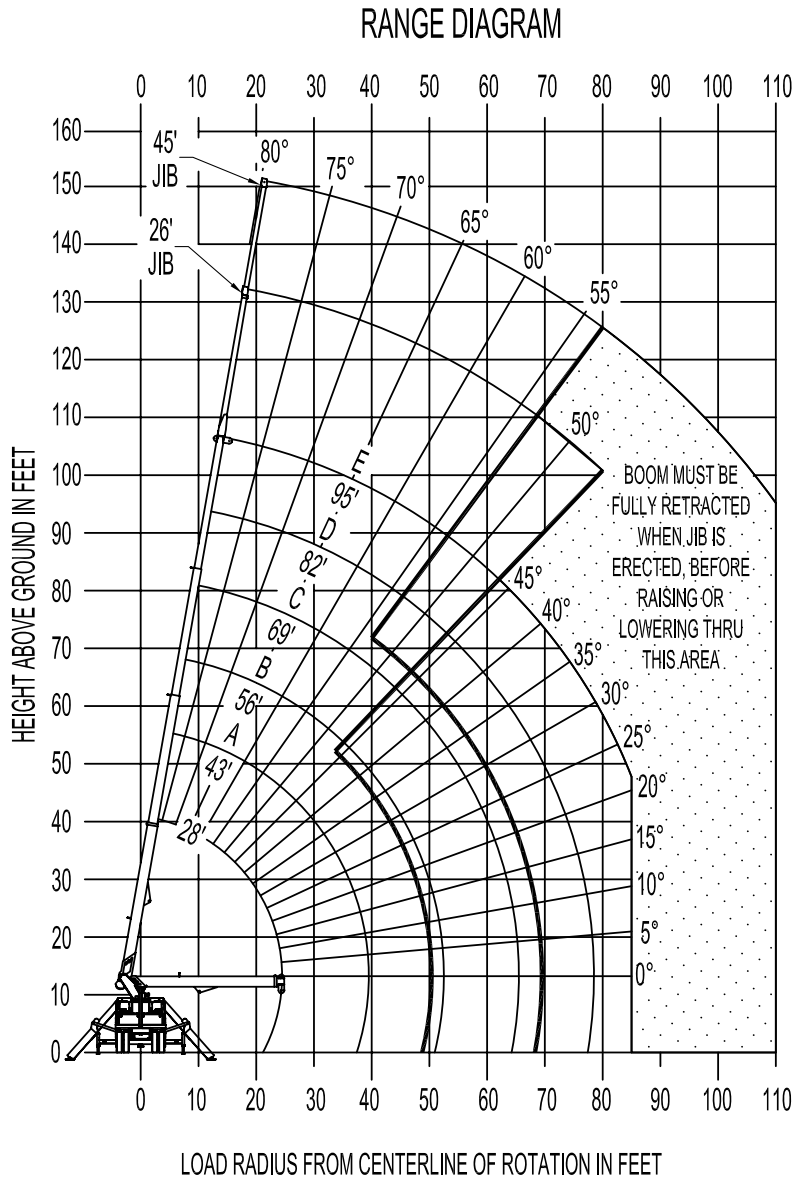

OUTRIGGERS AT FULL EXTENSION

**NOTE:**

1. OPERATE JIB BY RADIUS WHEN MAIN BOOM IS FULLY EXTENDED. INCREASE BOOM ANGLE IF NECESSARY TO MAINTAIN LOAD RADIUS.
2. WHEN BOOM IS RETRACTED, OPERATE JIB BY BOOM ANGLE. DO NOT EXCEED ANY RATED JIB CAPACITIES AT REDUCED BOOM LENGTHS.
3. CAPACITIES DO NOT EXCEED 85% STABILITY.
4. PERSONNEL HANDLING IS ALLOWED ONLY WITH FULL SPAN OUTRIGGERS.
5. LOAD RATINGS ABOVE BOLD LINE ARE STRUCTURALLY LIMITED.
6. BOOM LOAD RATINGS ARE BASED ON LOADED BOOM RADIUS.
7. LOADED BOOM ANGLES ARE GIVEN AS A REFERENCE ONLY.

**AREA OF OPERATION**

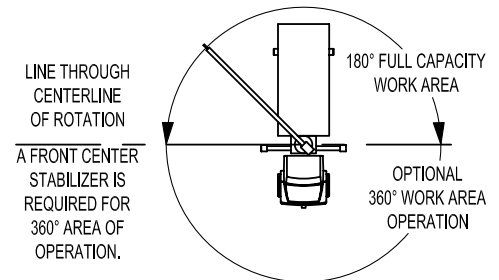

## CHASSIS SPECIFICATIONS

	2695F BoomTruck
Wheelbase (WB)	256" / 650 cm
Cab to Axle (CA)	192" / 488 cm
Cab to End of Frame (EOF)	316" / 803 cm
Frame Section Modulus	15.9 in3-110,000 psi / 758,428 kPa
Front Axle Gross Weight Rating	20,000 lb / 9072 kg
Rear Axle Gross Weight Rating	40,000 lb / 18 144 kg
Integral Front Frame Rails	Required for Front Stabilizer

Chassis data is minimum general requirements-not for engineering.  
 Actual dimensions and truck data will depend on truck selection and axle configuration.  
 \*Minimum chassis weight is required to meet 85% stability requirements.

## OPTIONS



### Radio Remote Control

Interference protected radio remotes let you get closer to your work and have full control over your machine. Includes battery charging feature and optional LMI screen.

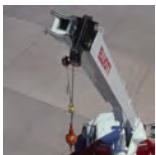

### Pin-On Jib Attachments

One piece & two piece telescoping or fixed jibs that stow on the side of the boom for easy placement while on the worksite.



### Continuous Boom Rotation

Add the convenience of 360 degree continuous rotation by adding a special boom rotation system for rotating without stops.



### Digger / Auger Attachment

Dig faster and deeper with Elliott's auger attachment, offering 41' of digging range and a hydraulically powered auger that stows on the boom.



### Tool Boxes

Optional tool boxes and bed storage can accommodate any storage need for tools, work materials and more.

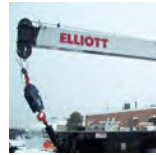

### Hook Block for Multi-Part Line

Elliott can install a 2-3 part hook block or a 4 part-hook block to improve lifting capabilities. The block can be stored at the rear of the bed.



### Gravity Levelled Basket

Elliott's pin-on work platform pins onto the boom for easy installation and removal. Gravity leveling and mechanical rotation makes it a great accessory for any worksite.

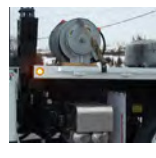

### Body Mounted Hose Reels and Circuits

Let us work with you to customize your tool compatibility by adding hose reels or hydraulic circuits to the crane bed.

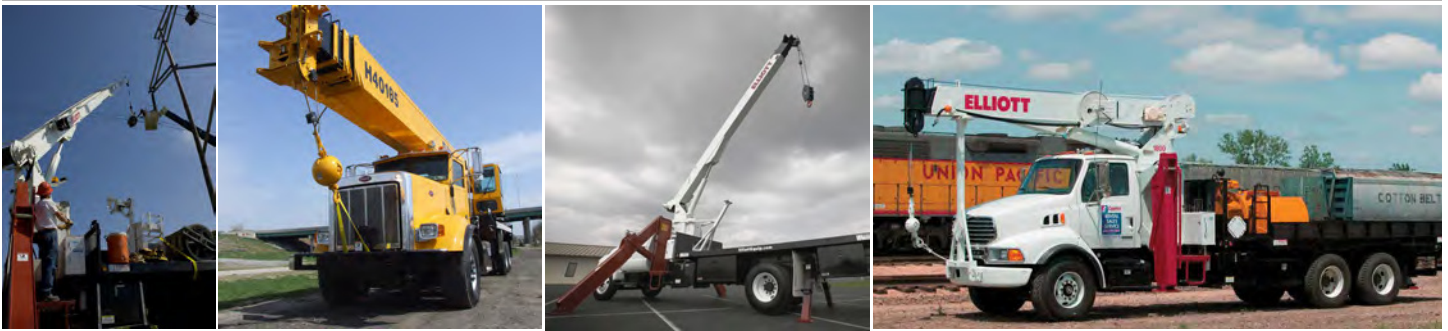

### 2695F-D SIDE VIEW DIAGRAM

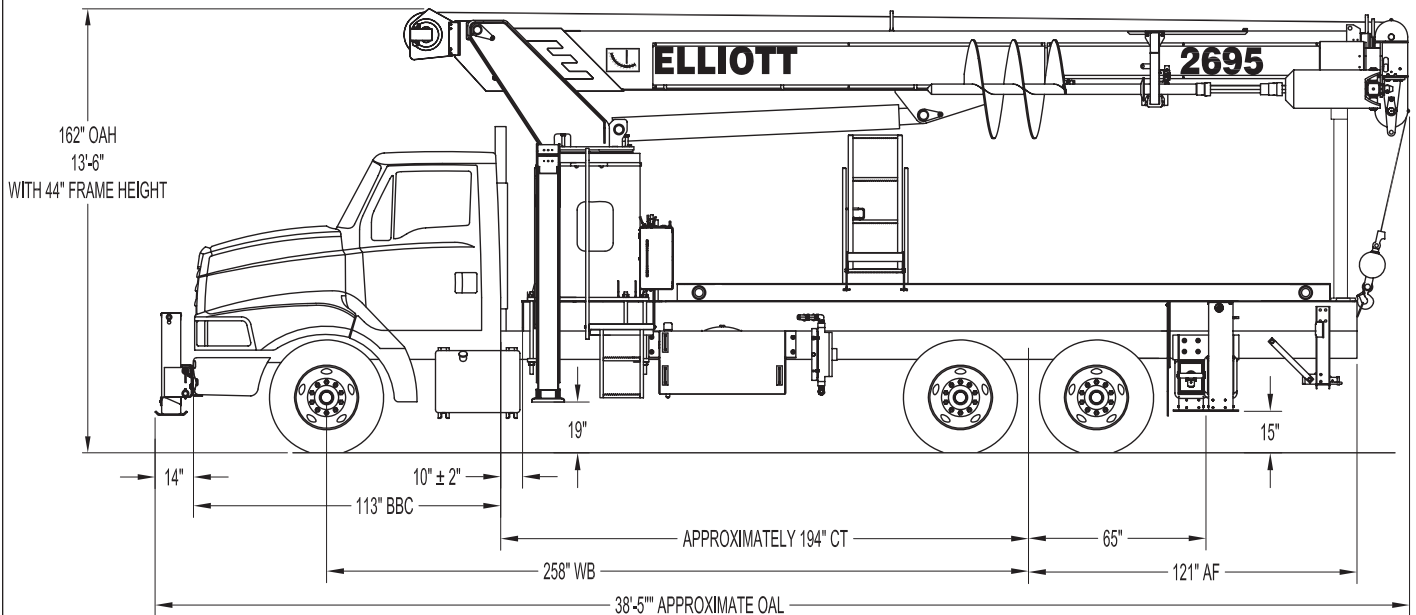

- **Maximum Vertical Reach** 152' / 46,3 m
- **Working Area** 180 Degrees Standard (360 Optional)
- **Lifting Capacity** 50,060 lbs / 22 707 kg
- **Boom Length** 95' / 29 m
- **Crane Weight (Standard)** 29,785 lbs / 13 510 kg
- **Jib Lengths** 26', 26-45' / 8-14 m
- **Winch Bare Drum Pull** 12,800 lbs / 5806 kg
- **Hydraulic Digger Radius** 41' / 12,5 m

- **Powered Boom Sections** 4
- **Overall Height** 13'6" / 4,1 m
- **Operator Controls** Dual Operator Standup
- **Outrigger Type Front** A-Frame
- **Outrigger Spread Front** 20'10" / 6,3 m
- **Outrigger Type Rear** Out-Down
- **Outrigger Spread Rear** 18'2" / 5,5 m

## TECHNICAL SPECIFICATIONS

**Crane Capacity:** 50,060 lbs at 5' load radius.

**Maximum Tip Height:** 107' height (152' with optional 45' jib)

**Control Console:** Dual operator standup control stations equipped with four single axis control levers for the main crane controls. Operator station includes LMI display, bubble level gauge, engine start/stop switch, signal horn button, variable speed throttle switch, lifting capacity chart, range diagram chart, boom angle indicator, system pressure gauge, 12V DC power source, and cup holder. Outrigger lever controls at control consoles.

**Boom:** Four-section fully proportional, high strength steel plated rectangular tube sections. A maximum boom tip height of 107' mounted on a truck. The boom nose contains one floating upper sheave and three lower sheaves. Assembly includes heavy-duty cylinder fittings, pivot pins, and replaceable wear pads.

**Winch:** Mounted at the base of the boom for a long fleet angle and flat level spooling of cable. Winch is driven by a planetary reducer and powered by a hydraulic motor. Burst-of-speed winch provides increased line speed. The winch brake is spring applied, pressure release design. Supplied with 425' of 9/16" diameter rotation resistant wire rope with a single line pull of 9,060 pounds, and a downhaul ball with swivel hook for single part line.

**Auger System:** 20,000 lb. automatic two-speed auger with 2 5/8" hex drive mounted at end of boom. Auger equipped with a 2 5/8" Kelly bar (auger extension bar) able to accept 24", 36", or 48" flightings. Auger and flighting to be stowed on side of boom from controls operated at main control station. Up to a 36" flighting to be stowed during transport. The auger provides a 41' digging radius. Auger will be provided with alternate radio remote control

Elliott Equipment Company reserves the right to change the specification of any unit at any time without prior notice. This brochure is only a statement of general specifications on the date of this publication. For more detailed info on specific Elliott trucks go to [www.elliottequip.com](http://www.elliottequip.com)

system with integral LMI display in radio transmitter.

**Load Moment Indicator System:** System senses hoist cylinder pressures, boom length and boom angle with hydraulic function lockout. The display console is equipped with a bar graph showing crane utilization, boom angle or boom length, a mode select controls for main boom and jib operation, and an anti-two block with an audio/visual warning and shut-off functions to limit hook-boom point contact.

**Outriggers:** One sets of "A" Frame main outriggers with 20'10" span, and one set of out and down underslung auxiliary outriggers with 18'2" span.

**Frame:** Full length, all welded rigid 4-plate design sub-frame. Sub-frame allows for bolt-on addition of 20' bed.

**Turret:** Reverse offset turret is one-piece weldment. Turret rotates on large diameter ball bearing.

**Rotation:** Hydraulic motor drives turret through double reduction planetary swing drive for 372-degree non-continuous rotation. The swing drive system has a spring applied, pressure release brake.

**Lift:** One double-acting long stroke cylinder provides smooth and stable boom elevation. Holding valve prevents boom from falling in event of hose failure.

**Boom Extension:** Incorporates a 2-stage hydraulic extension cylinder, attached to the largest boom section, with a proportional cable extension system driving the outermost sections.

**Hoses:** All high pressure hoses are wire braid reinforced with a minimum safety factor of 4 to 1.

**Cylinders:** All cylinders use microhoned cylinder tubing, chrome shafts, top grade packing and protective rod wipers. Cylinder-mounted holding valves provided on all load-holding cylinders.

**Hydraulic System:** Equipped with cable-shift PTO, gear pump, SAE O-ring face seals on pressure lines, and a 10-micron return line filter. The control valve distributes all flow to hoist system, swing circuit, and other crane functions. System is open center type.

**Oil Tank Capacity:** 120 gallon mounted to truck frame on roadside.

**Cab Equipment:** PTO cable with indicator lights installed in truck cab. U/L approved 5:BC dry chemical fire extinguisher installed in truck cab.

**Operators Manual & Video:** Two CD copies and one hard copy of operation, maintenance, safety and parts manual provided with each unit. Operational and safety video provided at delivery.

**Installation:** Unit installed on chassis, painted, system and tank filled with oil, tested, inspected, and ready to operate.

**Standard Paint:** Paint turret and boom white, outriggers red, and bed and boxes black.

**Bumper:** Bureau of Motor Carrier Safety rear bumper.

**Weight:** Approximately 29,785 lbs. with 22' steel-floor bed less truck.

**Truck Chassis Required:** Approx. 192" C.A. RBM 1,749,000 in-lb. per rail, 20,000 lb. front axle and 40,000 lb. GVWR required. Trucks must have front frame extension, 12V electrical system with high capacity alternator, cab clearance stop/tail/backup lights, and I.D. lamps. Recommended GVWR is minimum for BOOMTRUCK with flatbed only. Contact factory when additional equipment is to be added.

**Options:**

26'-45' Telescopic Pin-on Jib.

Superlink Shortjack Outriggers.

Gravity Leveled Steel Work Platform.

Much More...

## LOAD AND RANGE CHART - MAIN BOOM + JIB & DIGGER, FULL-SPAN OUTRIGGERS

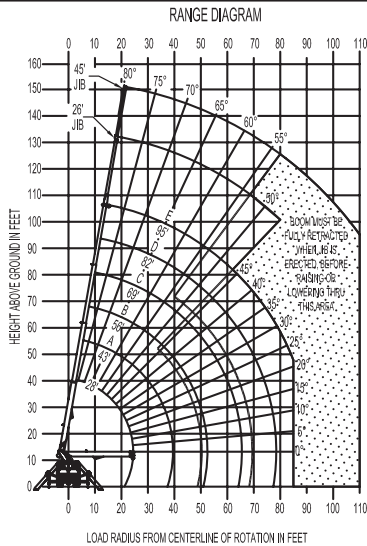

### ELLIOTT

EQUIPMENT COMPANY

### MODEL 2600 95-FT. BOOM WITH DIGGER

#### ALLOWABLE LINE PULL

1-PART LINE	2-PART LINE	3-PART LINE	4-PART LINE	5-PART LINE	6-PART LINE	NOTICE
						- DO NOT DEADHEAD LINE BLOCK AGAINST BOOM TIP WHEN EXTENDING BOOM. - KEEP AT LEAST 5 WRAPS OF LOADING ON THE WINCH DRUM AT ALL TIMES. - USE ONLY 9/16" DIAMETER WIRE ROPE AS SPECIFIED BELOW, WITH THE PROPER BREAKING STRENGTHS LISTED. - WITH THIS BLOCK SYSTEM MUST BE IN GOOD OPERATING CONDITION BEFORE OPERATING CRANE. SEE OPERATIONS & SAFETY MANUAL. - MAXIMUM CAPACITY WITH "BURST OF SPEED" IS 800 LBS.
MAX PULL: 9,600 lbs	19,200 lbs	28,800 lbs	38,400 lbs	48,000 lbs	52,000 lbs	
MAX PULL: 9,060 lbs	18,120 lbs	27,180 lbs	36,240 lbs	45,300 lbs	52,000 lbs	9/16" - SPIN RESISTANT (51 S.F.) 45,300-lbs BREAKING STRENGTH

DEDUCTIONS FROM RATED LOADS FOR HANDLING DEVICES SUPPLIED BY ELLIOTT EQUIPMENT CO.  
 OVERHAUL BALL ----- SEE OVERHAUL BALL MFR. NAMEPLATE  
 LOAD BLOCK ----- SEE BLOCK MFR. NAMEPLATE

#### BOOM LOAD RATINGS

LOAD RATINGS IN LBS. WITH OUTRIGGERS FULLY EXTENDED HORIZONTALLY AND VERTICALLY

LOAD RADIUS IN FEET	LOADED BOOM ANGLE	A		B		C		D		E		
		28-FT.	43-FT.	56-FT.	69-FT.	82-FT.	95-FT.					
5	78.5	50,060										
8	72	40,200	79	29,750								
10	67	33,700	76	29,550	80	23,300						
12	62.5	29,000	73.5	25,350	78	20,300						
14	57	25,400	70.5	22,250	75.5	18,000	79	18,400				
16	51.5	21,200	67.5	19,550	73.5	14,600	77.5	16,400	80	14,000		
20	39	16,900	61	17,050	69	13,700	74	13,300	77	12,000	79	9,750
25	11.5	11,600	52.5	12,750	63	9,700	69.5	10,500	73.5	10,000	76.5	8,650
30			42.5	9,750	57.5	8,100	65	9,050	70	8,500	73.5	7,650
35			31	7,750	50.5	6,550	60	7,650	66	7,050	70	6,600
40					43	5,350	55	6,550	62	6,150	66.5	5,700
45					34	4,200	49.5	5,400	57.5	5,200	63	4,900
50					21	3,050	43	4,350	53	4,200	59.5	4,250
55							35.5	3,500	48	3,550	56	3,600
60							26.5	2,750	43	2,900	51.5	3,000
65							11	2,050	37	2,350	47.5	2,450
70									30	1,850	42.5	1,900
75									20.5	1,450	37.5	1,500
80											31.5	1,100
85											24	500
0		6,000	0	3,000	0	1,000	0	500				
DEDUCTIONS FOR STOWED JIB (lbs)	900	600	450	350	300	250						
	600	400	300	250	200	200						

#### JIB LOAD RATINGS

LOAD RATINGS IN LBS WITH OUTRIGGERS AND STABILIZERS EXTENDED

26-ft FIXED LENGTH JIB			26'-45' TWO SECTION JIB					
LOAD RADIUS IN FEET	LOADED BOOM ANGLE	26-ft JIB	RETRACTED 26' JIB			EXTENDED 45' JIB		
			LOAD RADIUS IN FEET	LOADED BOOM ANGLE	26-ft JIB	LOAD RADIUS IN FEET	LOADED BOOM ANGLE	45-ft JIB
25	77	5,550	25	77	5,300	25	79	3,000
30	74.5	4,750	30	74.5	4,500	30	77	2,800
35	72	4,250	35	72	4,000	35	74.5	2,550
40	69.5	3,750	40	69.5	3,500	40	72.5	2,300
45	66.5	3,150	45	66.5	2,900	45	70.5	2,050
50	64	2,700	50	64	2,450	50	68	1,900
55	61.5	2,150	55	61.5	1,900	55	66	1,650
60	58.5	1,900	60	58.5	1,550	60	63.5	1,400
65	55.5	1,600	65	55.5	1,350	65	61.5	1,100
70	52.5	1,400	70	52.5	1,150	70	59	1,000
75	49.5	1,050	75	49.5	800	75	56.5	800
80	46	850	80	46	600	80	54	600

#### AREA OF OPERATION

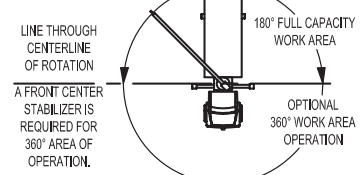

DEDUCTIONS FOR STOWED EXTENDABLE JIB (lbs)

DEDUCTIONS FOR STOWED FIXED LENGTH JIB (lbs)

- NOTE: 1. CAPACITIES DO NOT EXCEED 118% STABILITY. 2. PERSONNEL HANDLING IS ALLOWED ONLY WITH FULL SPAN OUTRIGGERS. 3. LOAD RATINGS ABOVE BOLD LINE ARE STRUCTURALLY LIMITED. 4. BOOM LOAD RATINGS ARE BASED ON LOADED BOOM RADIUS. 5. LOADED BOOM ANGLES ARE GIVEN AS A REFERENCE ONLY.

CRANE MEETS ASME B30.5 REQUIREMENTS AT TIME OF MANUFACTURE. DO NOT PAINT OVER ANY LABELS 1161550 012100

**DIGGING RANGE AND LOAD DIAGRAM (DATA ON FOLLOWING PAGE)**

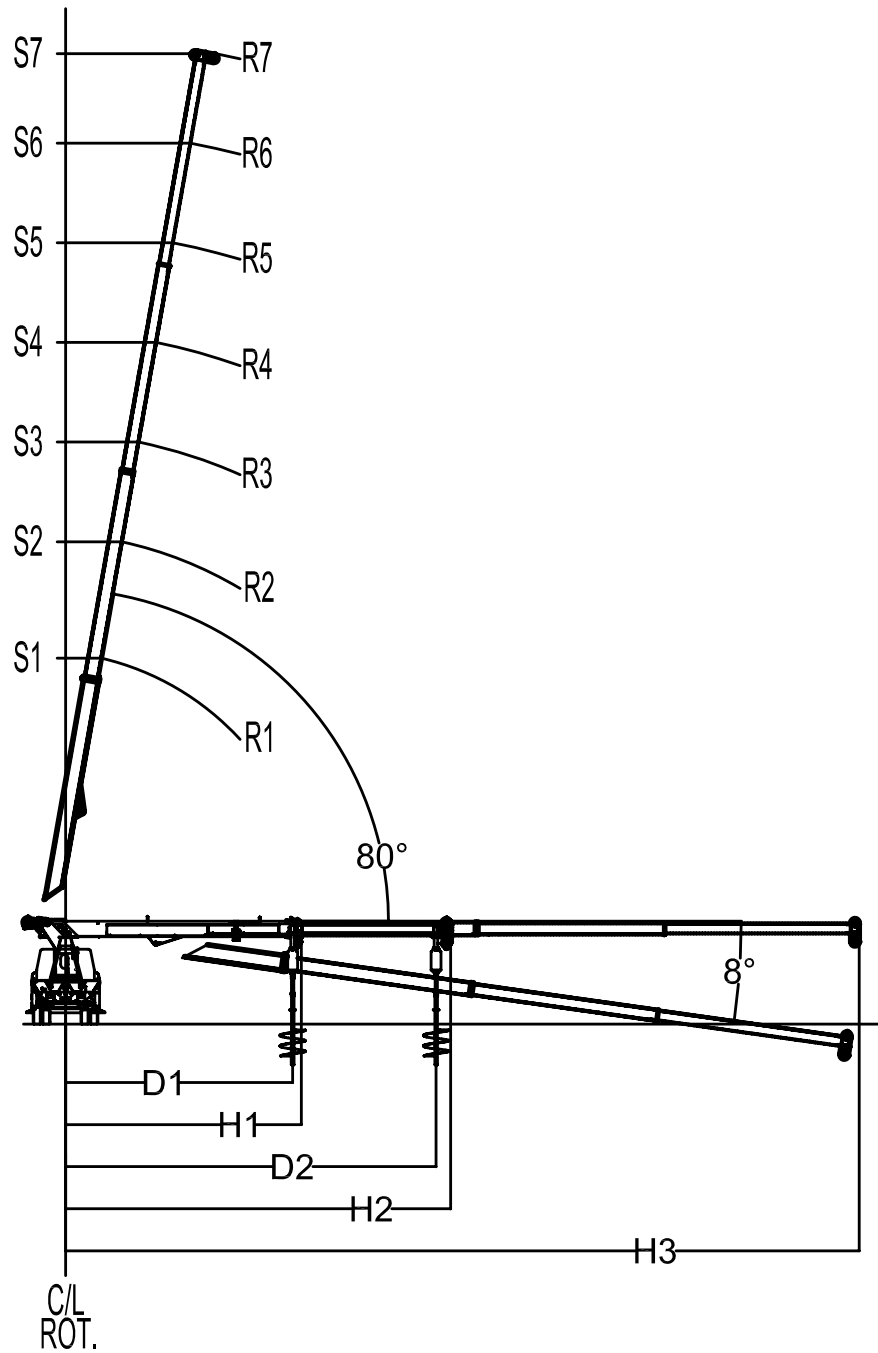

**DIGGING RANGE AND LOAD DATA (REFERENCE PREVIOUS PAGE)**

**CAPACITIES & DIMENSIONAL DATA**

<b>MODEL</b>	<b>30105F-D</b>	<b>3095F-D</b>	<b>26105F-D</b>	<b>2695F-D</b>
<b>MAX CAPACITY</b>	60,000 LB	60,000 LB	52,000 LB	52,000 LB
<b>CAPACITY @ 10 FT RADIUS</b>	30,650 LB	35,600 LB	29,650 LB	33,700 LB
<b>SHEAVE HEIGHT</b>				
<b>S1</b>	43 FT	40 FT	44 FT	41 FT
<b>S2</b>	58 FT	56 FT	59 FT	55 FT
<b>S3</b>	70 FT	67 FT	71 FT	68 FT
<b>S4</b>	82 FT	80 FT	83 FT	81 FT
<b>S5</b>	93 FT	93 FT	94 FT	94 FT
<b>S6</b>	105 FT	105 FT	106 FT	106 FT
<b>S7</b>	115 FT		116 FT	
<b>LOAD RADIUS</b>				
<b>R1</b>	31 FT	28 FT	31 FT	28 FT
<b>R2</b>	46 FT	43 FT	46 FT	43 FT
<b>R3</b>	58 FT	56 FT	58 FT	56 FT
<b>R4</b>	70 FT	69 FT	70 FT	69 FT
<b>R5</b>	82 FT	82 FT	82 FT	82 FT
<b>R6</b>	94 FT	95 FT	94 FT	95 FT
<b>R7</b>	105 FT		105 FT	
<b>HORIZONTAL REACH</b>				
<b>H1</b>	31 FT	28.5 FT	31 FT	28.5 FT
<b>H2</b>	48.5 FT	46 FT	48.5 FT	46 FT
<b>H3</b>	105 FT	95 FT	105 FT	95 FT
<b>DIGGING RADIUS</b>				
<b>D1</b>	27 FT	24.5 FT	27 FT	24.5 FT
<b>D2</b>	44 FT	41 FT	44 FT	41 FT

## TRUCK CHASSIS SPECIFICATIONS

	2695F-D BoomTruck
Wheelbase (WB)	268" / 681 cm
Cab to Tandem (CT)	192" / 487 cm
Cab to End of Frame (EOF)	312" / 792 cm
Frame Section Modulus	30.0 in3-110,000 psi
Front Axle Gross Weight Rating	20,000 lb / 9071 kg
Rear Axle Gross Weight Rating	40,000 lb / 18 143 kg
Integral Front Frame Rails	Required for Front Stabilizer

Chassis data is minimum general requirements-not for engineering.  
Actual dimensions and truck data will depend on truck selection and axle configuration.  
\*Minimum chassis weight is required to meet 85% stability requirements.

## OPTIONS



### Hydraulic Pole Claw

Combine Elliott's digger system with a hydraulic pole claw to dig holes and place poles with a single machine.

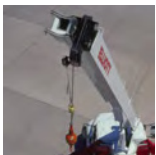

### Pin-On Jib Attachments

One piece & two piece telescoping or fixed jibs that stow on the side of the boom for easy placement while on the worksite.



### Continuous Boom Rotation

Add the convenience of 360 degree continuous rotation by adding a special boom rotation system for rotation without stops.



### Digger / Auger Flightings

Dig faster and deeper with Elliott's selection of auger flightings up to 48" in diameter that provide an industry-leading 41' digging radius and more power out of the hole.



### Tool Boxes

Optional tool boxes and bed storage can accommodate any storage need for tools, work materials and more.



### Hook Block for Multi-Part Line

Elliott can install a 2-3 part hook block or a 4 part-hook block to improve lifting capabilities. The block can be stored at the rear of the bed.



### Gravity Levelled Basket

Elliott's pin-on work platform pins onto the boom for easy installation and removal. Gravity leveling and mechanical rotation makes it a great accessory for any worksite.

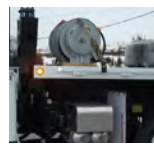

### Body Mounted Hose Reels and Circuits

Let us work with you to customize your tool compatibility by adding hose reels or hydraulic circuits to the crane bed.

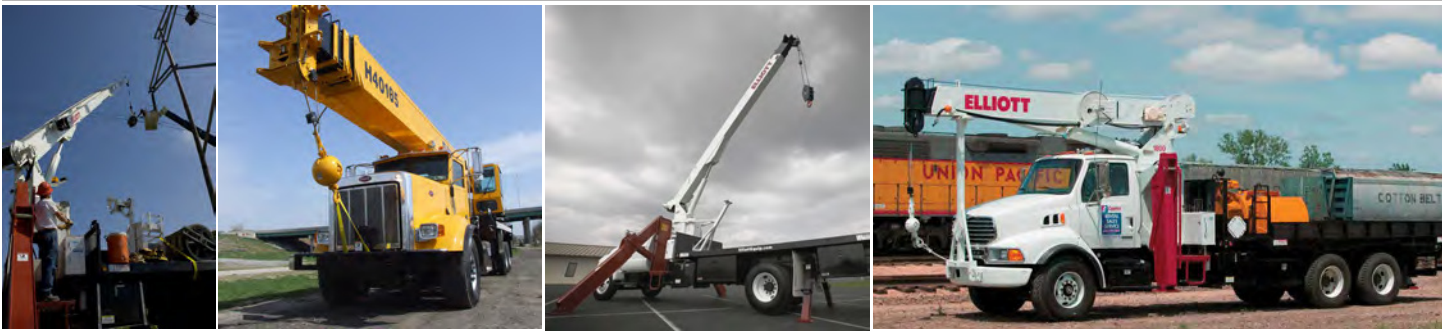

### 26105F SIDE VIEW DIAGRAM

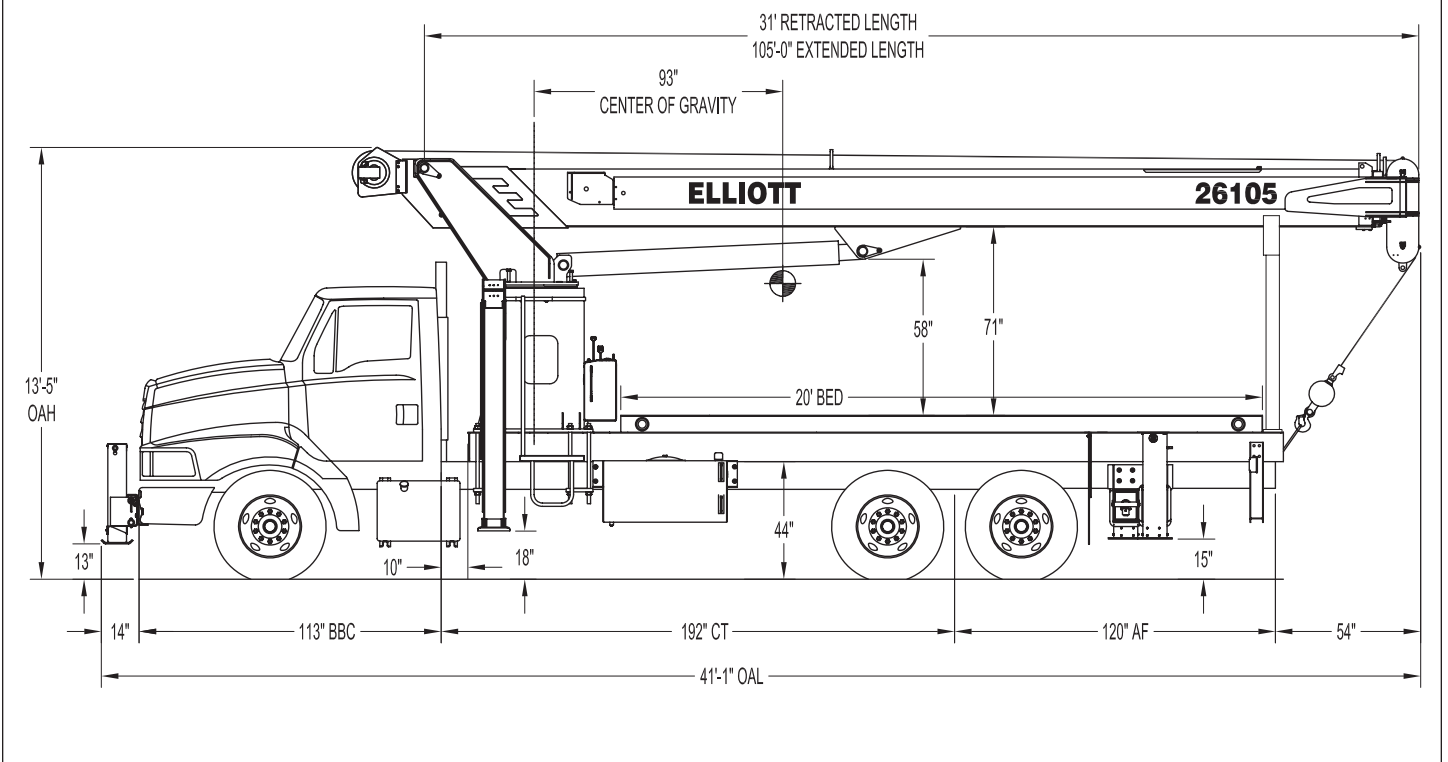

- |                                 |                                     |                                 |                                |
|---------------------------------|-------------------------------------|---------------------------------|--------------------------------|
| • <b>Maximum Vertical Reach</b> | 162' / 49,4 m                       | • <b>Powered Boom Sections</b>  | 4                              |
| • <b>Working Area</b>           | 180 Degrees Standard (360 Optional) | • <b>Overall Height</b>         | 13'5" / 4,1 m                  |
| • <b>Lifting Capacity</b>       | 52,000 lbs / 23 587 kg              | • <b>Operator Controls</b>      | Dual Operator Standup Controls |
| • <b>Boom Length</b>            | 105' / 32 m                         | • <b>Outrigger Type Front</b>   | A-Frame                        |
| • <b>Crane Weight (Dry)</b>     | 26,040 lbs / 11 811 kg              | • <b>Outrigger Spread Front</b> | 20'10" / 6,3 m                 |
| • <b>Jib Length</b>             | 26', 26'-45' / 8 m, 8-13,7 m        | • <b>Outrigger Type Rear</b>    | Out-Down                       |
| • <b>Winch Bare Drum Pull</b>   | 12,800 lbs / 5806 kg                | • <b>Outrigger Spread Rear</b>  | 18'2" / 5,5 m                  |

## TECHNICAL SPECIFICATIONS

**Crane Capacity:** 52,000 lbs at 5' load radius.

**Maximum Tip Height:** 117' height (162' with optional 45' jib)

**Control Console:** Rotating turret dual operator standup control station equipped with four single axis control levers for the main crane controls. Operator station includes LMI display, bubble level gauge, engine start/stop switch, signal horn button, variable foot throttle, lifting capacity chart, range diagram chart, boom angle indicator, system pressure gauge, 12V DC power source, and cup holder. Outrigger lever controls at control consoles.

**Boom:** Four-section fully proportional, high strength steel plated rectangular tube sections. A maximum boom tip height of 117' mounted on a truck. The boom nose contains one floating upper sheave and three lower sheaves. Assembly includes heavy-duty cylinder fittings, pivot pins, and replaceable wear pads.

**Winch:** Mounted at the base of the boom for a long fleet angle and flat level spooling of cable. Winch is driven by a planetary reducer and powered by a hydraulic motor. Burst-of-speed winch provides increased line speed. The winch brake is spring applied, pressure release design. Supplied with 425' of 9/16" diameter rotation resistant wire rope with a single line pull of 9,060 pounds, and a downhaul ball with swivel hook for single part line.

**Load Moment Indicator System:** System senses hoist cylinder pressures, boom length and boom angle with hydraulic function lockout. The display console is equipped with a bar graph showing crane utilization, boom angle or boom length, a mode select controls for main boom and jib operation, and an anti-two block with an audio/visual warning and shut-off functions to limit hook-boom point contact.

Elliott Equipment Company reserves the right to change the specification of any unit at any time without prior notice. This brochure is only a statement of general specifications on the date of this publication. For more detailed info on specific Elliott trucks go to [www.elliottequip.com](http://www.elliottequip.com)

**Outriggers:** One sets of "A" Frame mian outriggers with 20'10" span, and one set of out and down overframe rear outriggers with 18'2" span.

**Frame:** Full length, all welded rigid 4-plate design sub-frame. Sub-frame allows for bolt-on addition of 20' bed.

**Turret:** Reverse offset turret is one-piece weldment. Turret rotates on large diameter ball bearing.

**Rotation:** Hydraulic motor drives turret through double reduction planetary swing drive for 372-degree non-continuous rotation. The swing drive system has a spring applied, pressure release brake.

**Lift:** One double-acting long stroke cylinder provides smooth and stable boom elevation. Holding valve prevents boom from falling in event of hose failure.

**Boom Extension:** Incorporates a 2-stage hydraulic extension cylinder, attached to the largest boom section, with a proportional cable extension system driving the outermost sections.

**Hoses:** All high pressure hoses are wire braid reinforced with a minimum safety factor of 4 to 1.

**Cylinders:** All cylinders use microhoned cylinder tubing, chrome shafts, top grade packing and protective rod wipers. Cylinder-mounted holding valves provided on all load-holding cylinders.

**Hydraulic System:** Equipped with cable-shift PTO, three-section gear pump, SAE O-ring face seals on pressure lines, and a 10-micron return line filter. The control valve distributes all flow to hoist system, swing circuit, and other crane functions. System is open center type.

**Oil Tank Capacity:** 120 gallon mounted to truck frame on roadside.

**Cab Equipment:** PTO switch with indicator lights installed in truck cab. U/L approved 5:BC dry chemical fire

extinguisher installed in truck cab.

**Operators Manual & Video:** Two CD copies and one hard copy of operation, maintenance, safety and parts manual provided with each unit. Operational and safety video provided at delivery.

**Installation:** Unit installed on chassis, painted, system and tank filled with oil, tested, inspected, and ready to operate.

**Standard Paint:** Paint turret and boom white, outriggers red, and bed and boxes black.

**Bumper:** Bureau of Motor Carrier Safety rear bumper.

**Weight:** Approximately 26,040 lbs. with 20' steel-floor bed less truck.

**Truck Chassis Required:** Approx. 192" C.T. RBM 1,749,000 in-lb. per rail, 20,000 lb. front axle and 60,000 lb. GVWR required. Trucks must have front frame extension, 12V electrical system with high capacity alternator, cab clearance stop/tail/backup lights, and I.D. lamps. Recommended GVWR is minimum for BoomTruck with flatbed only. Contact factory when additional equipment is to be added.

**Options:**

26'-45' Telescopic Pin-On Jib.

Radio Remote Controls.

Superlink Short Jack Outriggers.

2 Person Gravity Leveled Steel Basket.

Front Jack for 360 Degree Crane Operation.

Rotation Resistant Wire Rope.

Hydraulic Tool Circuits on Bed.

Much More...

**LOAD CHART - MAIN BOOM, FULL-SPAN OUTRIGGERS**

**MAIN BOOM LOAD RATINGS WITH FULLY EXTENDED OUTRIGGERS**

LOAD RADIUS IN FEET	LOADED BOOM ANGLE	A		B		C		D		E		F		
		31-FT.	46-FT.	46-FT.	58-FT.	70-FT.	82-FT.	94-FT.	105-FT.					
5	80	52,000												
6	78	44,000												
8	74	36,600	79.5	30,000										
10	70	31,000	77	27,000	80	20,000								
12	66	26,500	74.5	24,900	78	19,800								
14	61.5	20,500	72	21,800	76	17,700	79.5	18,500						
16	57	18,500	69	19,500	74	16,000	77.5	16,000						
18	52	15,900	66	15,800	72	14,400	76	14,800	78.5	13,700				
20	47	14,300	63	12,800	69.5	11,500	74	13,400	77	12,500	79.5	11,500		
25	30.5	10,300	55.5	11,000	64.5	9,500	69.5	10,900	73.5	10,300	76	9,750	78.5	8,400
30			47.5	9,300	58.5	7,950	65.5	9,000	70	8,500	72.5	8,050	75.5	7,600
35			37.5	8,500	52.5	6,700	60.5	7,500	66	7,050	70	6,650	72.5	6,200
40			23	6,300	45.5	5,600	55.5	6,300	62	5,800	66.5	5,600	69.5	5,300
45					37	4,000	50	5,300	57.5	5,000	63	4,700	66.5	4,550
50					26.5	3,850	44	4,600	53	4,400	59	4,300	63.5	3,900
55							37	3,800	48.5	3,800	55.5	3,800	60	3,450
60							28.5	2,700	43	3,250	51.5	3,300	56.5	3,000
65							15.5	2,150	37	2,700	47	2,800	53	2,700
70									30	2,150	42.5	2,250	49.5	2,350
75									20.5	1,800	37	1,900	45.5	1,850
80											30.5	1,000	41	1,450
85											23	600	36	1,150
90													30.5	850
0		5,500	0	2,900	0	1,100	0	500						
DEDUCTIONS FOR STOWED JIB (lbs)		850		600		450		400		350		300		250
		550		350		300		250		200		150		150

**JIB LOAD RATINGS WITH FULLY EXTENDED OUTRIGGERS**

26-ft FIXED LENGTH JIB			26'-45' TWO SECTION JIB			
LOAD RADIUS IN FEET	LOADED BOOM ANGLE	26-ft JIB	RETRACTED 26' JIB		EXTENDED 45' JIB	
			LOAD RADIUS IN FEET	LOADED BOOM ANGLE	26-ft JIB	LOADED BOOM ANGLE
30	78.5	4,400	30	78.5	4,150	
35	76.5	4,000	35	76	3,750	77
40	74	3,600	40	74	3,350	75.5
45	72	3,100	45	71.5	2,850	74
50	69.5	2,700	50	69	2,450	72
55	67	2,300	55	66.5	2,050	70
60	64.5	2,000	60	64	1,750	68
65	62	1,700	65	61.5	1,450	66
70	59	1,500	70	59	1,250	64
75	56.5	1,300	75	56	1,050	61.5
80	53.5	1,100	80	53.5	850	59.5
85	50.5	900	85	50.5	650	57
90	47.5	700	90			55
			95			52

**NOTICE**

- DO NOT DEADHEAD LINE BLOCK AGAINST BOOM TIP WHEN EXTENDING BOOM.
- KEEP AT LEAST 5 WRAPS OF LOADLINE ON THE WINCH DRUM AT ALL TIMES.
- USE ONLY 9/16" DIAMETER WIRE ROPE, AS SPECIFIED BELOW, WITH THE PROPER BREAKING STRENGTHS LISTED.
- ANTI-TWO-BLOCK SYSTEM MUST BE IN GOOD OPERATING CONDITION BEFORE OPERATING CRANE. SEE OPERATION & SAFETY MANUAL.

DEDUCTIONS FOR STOWED EXTENDABLE JIB (lbs)  
DEDUCTIONS FOR STOWED FIXED LENGTH JIB (lbs)

**1-PART LINE**



**2-PART LINE**



**3-PART LINE**



**4-PART LINE**



**5-PART LINE**



**6-PART LINE**



ELLIOTT EQUIPMENT CO. SUPPLIED  
LOADLINE EQUIPMENT DEDUCTIONS:  
DOWNHAUL WEIGHT .....180 lbs  
ONE SHEAVE BLOCK.....375 lbs  
TWO SHEAVE BLOCK.....640 lbs  
THREE SHEAVE BLOCK.....870 lbs  
AUXILIARY SHEAVE.....100 lbs

MAX PULL: 9,060 lbs    18,120 lbs    27,180 lbs    36,240 lbs    45,300 lbs    52,000 lbs

9/16" -SPIN RESISTANT 5:1 S.F.) 45,300-lbs. BREAKING STRENGTH

CRANE MEETS ASME B30.5 REQUIREMENTS AT TIME OF MANUFACTURE

DO NOT PRINT OVER ANY LABELS 1113370 07106

**RANGE CHART - MAIN BOOM + JIB , FULL-SPAN OUTRIGGERS**

**RANGE DIAGRAM WITH FULL SPAN OUTRIGGERS**

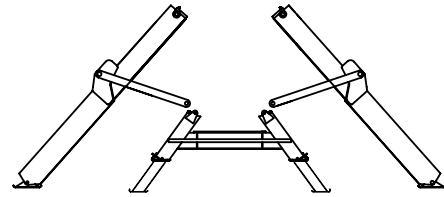
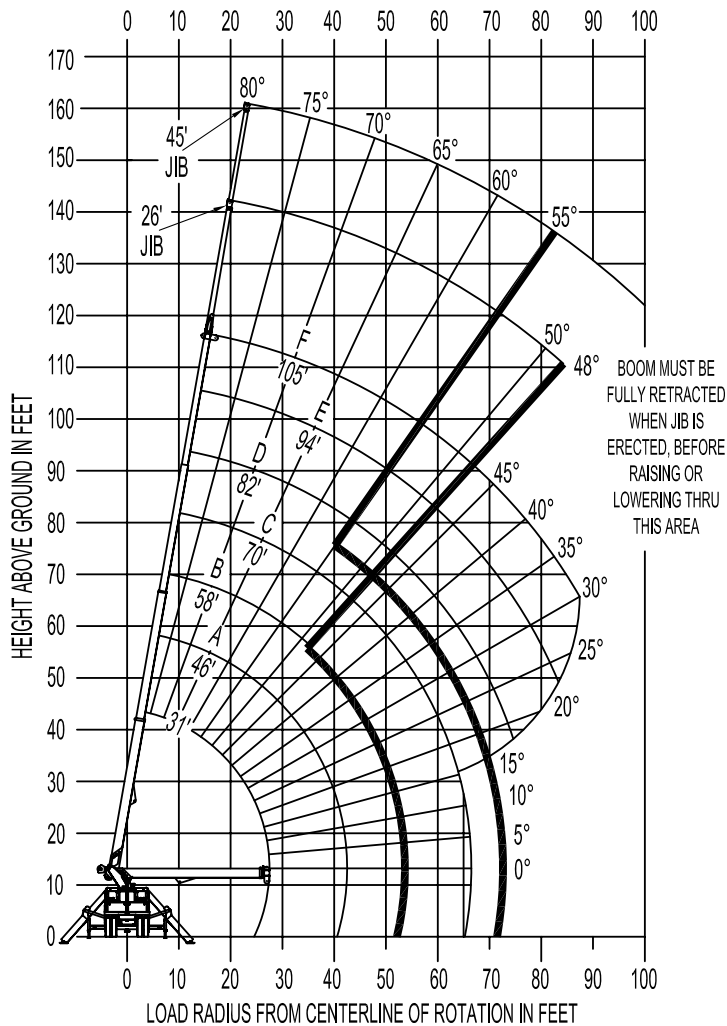

OUTRIGGERS AT FULL EXTENSION

**NOTE:**

1. OPERATE JIB BY RADIUS WHEN MAIN BOOM IS FULLY EXTENDED. INCREASE BOOM ANGLE IF NECESSARY TO MAINTAIN LOAD RADIUS.
2. WHEN BOOM IS RETRACTED, OPERATE JIB BY BOOM ANGLE. DO NOT EXCEED ANY RATED JIB CAPACITIES AT REDUCED BOOM LENGTHS.
3. CAPACITIES DO NOT EXCEED 85% STABILITY.
4. PERSONNEL HANDLING IS ALLOWED ONLY WITH FULL SPAN OUTRIGGERS
5. LOAD RATINGS ABOVE BOLD LINE ARE STRUCTURALLY LIMITED.
6. BOOM LOAD RATINGS ARE BASED ON LOADED BOOM RADIUS.
7. LOADED BOOM ANGLES ARE GIVEN AS A REFERENCE ONLY.

**AREA OF OPERATION**

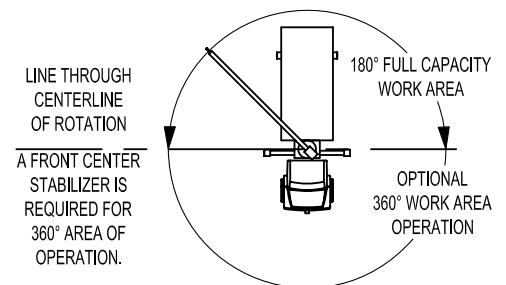

**CHASSIS SPECIFICATIONS**

	26105F BoomTruck
Wheelbase (WB)	256" / 650 cm
Cab to Tandem (CT)	192" / 488 cm
Cab to End of Frame (EOF)	312" / 792 cm
Frame Section Modulus	30.0 in3-110,000 psi / 492 cm3-758,428 kPa
Front Axle Gross Weight Rating	20,000 lb / 9072 kg
Rear Axle Gross Weight Rating	40,000 lb / 18144 kg
Integral Front Frame Rails	Required for Front Stabilizer

Chassis data is minimum general requirements-not for engineering.  
 Actual dimensions and truck data will depend on truck selection and axle configuration.  
 \*Minimum chassis weight is required to meet 85% stability requirements.

**OPTIONS**



**Radio Remote Control**

Interference protected radio remotes let you get closer to your work and have full control over your machine. Includes battery charging feature and optional LMI screen.

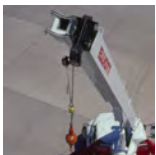

**Pin-On Jib Attachments**

One piece & two piece telescoping or fixed jibs that stow on the side of the boom for easy placement while on the worksite.



**Continuous Boom Rotation**

Add the convenience of 360 degree continuous rotation by adding a special boom rotation system for rotation without stops.



**Digger / Auger Attachment**

Dig faster and deeper with Elliott's auger attachment, offering 44' of digging range and a hydraulically powered auger that stows on the boom.



**Tool Boxes**

Optional tool boxes and bed storage can accommodate any storage need for tools, work materials and more.

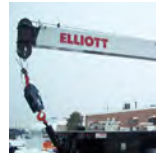

**Hook Block for Multi-Part Line**

Elliott can install a 2-3 part hook block or a 4 part-hook block to improve lifting capabilities. The block can be stored at the rear of the bed.



**Gravity Levelled Basket**

Elliott's pin-on work platform pins onto the boom for easy installation and removal. Gravity leveling and mechanical rotation makes it a great accessory for any worksite.

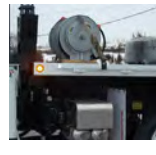

**Body Mounted Hose Reels and Circuits**

Let us work with you to customize your tool compatibility by adding hose reels or hydraulic circuits to the crane bed.

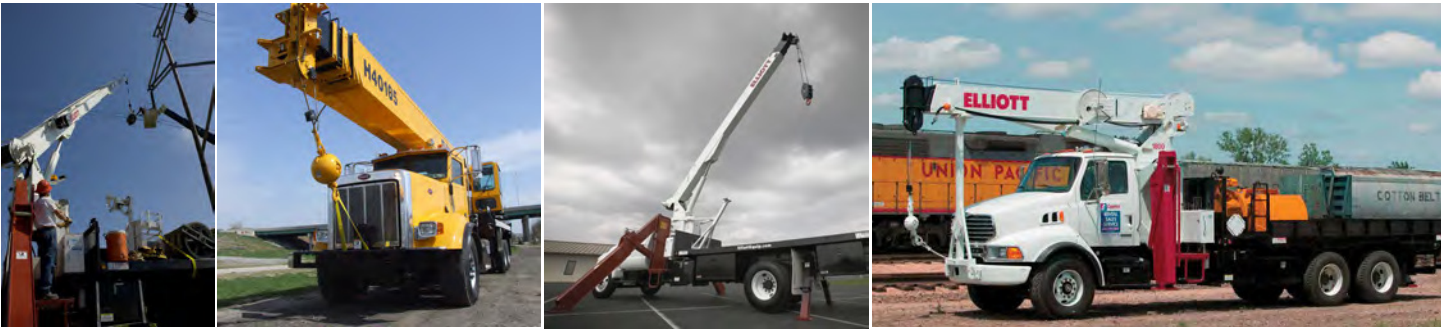

### 26105F-D SIDE VIEW DIAGRAM

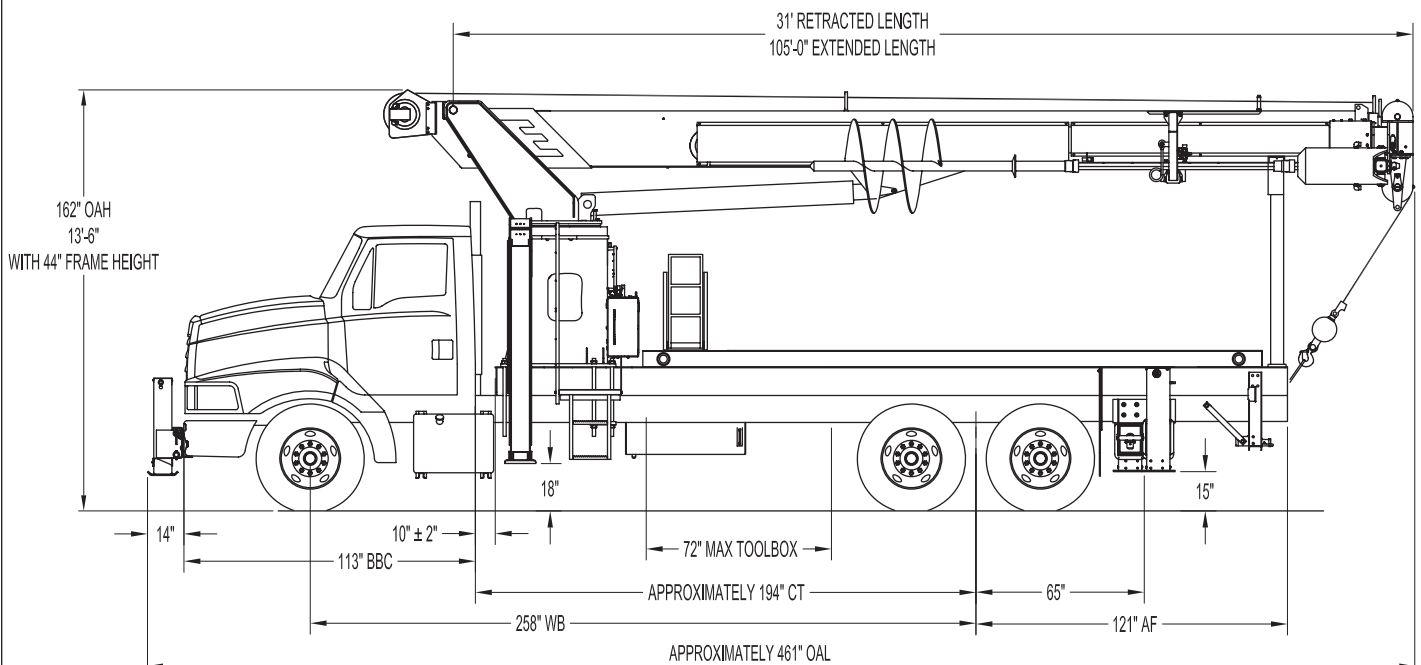

- **Maximum Vertical Reach** 162'/49,3 m
- **Working Area** 180 Degrees Standard (360 Optional)
- **Lifting Capacity** 52,000 lbs/23 587 kg
- **Boom Length** 105'/32 m
- **Crane Weight (Standard)** 29,785 lbs/13 510 kg
- **Jib Lengths** 26', 26-45'/ 8-13,7 m
- **Winch Bare Drum Pull** 12,800 lbs/5806 kg
- **Hydraulic Digger Radius** 44'/13,4 m

- **Powered Boom Sections** 4
- **Overall Height** 13'6\"/>
- **Operator Controls** Dual Operator Standup
- **Outrigger Type Front** A-Frame
- **Outrigger Spread Front** 20'10\"/>
- **Outrigger Type Rear** Out-Down
- **Outrigger Spread Rear** 18'2\"/>

## TECHNICAL SPECIFICATIONS

**Crane Capacity:** 52,000 lbs at 5' load radius.

**Maximum Tip Height:** 117' height (162' with optional 45' jib)

**Control Console:** Dual operator standup control stations equipped with four single axis control levers for the main crane controls. Operator station includes LMI display, bubble level gauge, engine start/stop switch, signal horn button, variable speed throttle switch, lifting capacity chart, range diagram chart, boom angle indicator, system pressure gauge, 12V DC power source, and cup holder. Outrigger lever controls at control consoles.

**Boom:** Four-section fully proportional, high strength steel plated rectangular tube sections. A maximum boom tip height of 117' mounted on a truck. The boom nose contains one floating upper sheave and three lower sheaves. Assembly includes heavy-duty cylinder fittings, pivot pins, and replaceable wear pads.

**Winch:** Mounted at the base of the boom for a long fleet angle and flat level spooling of cable. Winch is driven by a planetary reducer and powered by a hydraulic motor. Burst-of-speed winch provides increased line speed. The winch brake is spring applied, pressure release design. Supplied with 425' of 9/16" diameter rotation resistant wire rope with a single line pull of 9,060 pounds, and a downhaul ball with swivel hook for single part line.

**Auger System:** 20,000 lb. automatic two-speed auger with 2 5/8" hex drive mounted at end of boom. Auger equipped with a 2 5/8" Kelly bar (auger extension bar) able to accept 24", 36", or 48" flightings. Auger and flighting to be stowed on side of boom from controls operated at main control station. Up to a 36" flighting to be stowed during transport. The auger provides a 44' digging radius. Auger will be provided with radio remote control system with

integral LMI display in radio transmitter.

**Load Moment Indicator System:**

System senses hoist cylinder pressures, boom length and boom angle with hydraulic function lockout. The display console is equipped with a bar graph showing crane utilization, boom angle or boom length, a mode select controls for main boom and jib operation, and an anti-two block with an audio/visual warning and shut-off functions to limit hook-boom point contact.

**Outriggers:** One set of "A" Frame main outriggers with 20'10" span, and one set of out and down underslung auxiliary outriggers with 18'2" span.

**Frame:** Full length, all welded rigid 4-plate design sub-frame. Sub-frame allows for bolt-on addition of 20' bed.

**Turret:** Reverse offset turret is one-piece weldment. Turret rotates on large diameter ball bearing.

**Rotation:** Hydraulic motor drives turret through double reduction planetary swing drive for 372-degree non-continuous rotation. The swing drive system has a spring applied, pressure release brake.

**Lift:** One double-acting long stroke cylinder provides smooth and stable boom elevation. Holding valve prevents boom from falling in event of hose failure.

**Boom Extension:** Incorporates a 2-stage hydraulic extension cylinder, attached to the largest boom section, with a proportional cable extension system driving the outermost sections.

**Hoses:** All high pressure hoses are wire braid reinforced with a minimum safety factor of 4 to 1.

**Cylinders:** All cylinders use microhoned cylinder tubing, chrome shafts, top grade packing and protective rod wipers. Cylinder-mounted holding valves provided on all load-holding cylinders.

**Hydraulic System:** Equipped with

cable-shift PTO, gear pump, SAE O-ring face seals on pressure lines, and a 10-micron return line filter. The control valve distributes all flow to hoist system, swing circuit, and other crane functions. System is open center type.

**Oil Tank Capacity:** 120 gallon mounted to truck frame on roadside.

**Cab Equipment:** PTO with indicator lights installed in truck cab. U/L approved 5:BC dry chemical fire extinguisher installed in truck cab.

**Operators Manual & Video:** Two CD copies and one hard copy of operation, maintenance, safety and parts manual provided with each unit. Operational and safety video provided at delivery.

**Installation:** Unit installed on chassis, painted, system and tank filled with oil, tested, inspected, and ready to operate.

**Standard Paint:** Paint turret and boom white, outriggers red, and bed and boxes black.

**Bumper:** Bureau of Motor Carrier Safety rear bumper.

**Weight:** Approximately 29,785 lbs. with 20' steel-floor bed less truck.

**Truck Chassis Required:** Approx. 192" C.T., RBM 1,749,000 in-lb. per rail, 20,000 lb. front axle and 40,000 lb. GVWR required. Trucks must have front frame extension, 12V electrical system with high capacity alternator, cab clearance stop/tail/backup lights, and I.D. lamps. Recommended GVWR is minimum for BoomTruck with flatbed only. Contact factory when additional equipment is to be added.

**Options:**

26'-45' Telescopic Pin-on Jib.

Superlink Shortjack Outriggers.

Gravity Leveled Steel Work Platform.

Much More...

Elliott Equipment Company reserves the right to change the specification of any unit at any time without prior notice. This brochure is only a statement of general specifications on the date of this publication. For more detailed info on specific Elliott trucks go to [www.elliottequip.com](http://www.elliottequip.com)

## LOAD & RANGE CHART - MAIN BOOM + JIB, FULL-SPAN OUTRIGGERS

RANGE DIAGRAM WITH FULL SPAN OUTRIGGERS

HEIGHT ABOVE GROUND IN FEET

LOAD RADIUS FROM CENTERLINE OF ROTATION IN FEET

BOOM MUST BE FULLY RETRACTED WHEN JIB IS ERECTED, BEFORE RAISING OR LOWERING THROUGH THE AREA.

### ELLIOTT MODEL 2600 105-FT. BOOM

EQUIPMENT COMPANY

#### ALLOWABLE LINE PULL

1-PART LINE	2-PART LINE	3-PART LINE	4-PART LINE	5-PART LINE	6-PART LINE	NOTICE
						- DO NOT DEADEND LINE BLOCK AGAINST BOOM TIP WHEN EXTENDING BOOM. - KEEP AT LEAST 5 WRAPS OF LOADING ON THE WIND DRUM AT ALL TIMES. - USE ONLY 3/16" DIAMETER WIRE ROPE, AS SPECIFIED BELOW, WITH THE PROPER BREAKING STRENGTHS LISTED. - ANTI-SLACK SYSTEM MUST BE IN GOOD OPERATING CONDITION BEFORE OPERATING CRANE. SEE OPERATION & SAFETY MANUAL. - MAXIMUM CAPACITY WITH "BURST OF SPEED" IS 500 LBS.
MAX PULL: 9,600 lbs	19,200 lbs	28,800 lbs	38,400 lbs	48,000 lbs	52,000 lbs	
MAX PULL: 9,000 lbs	18,120 lbs	27,180 lbs	36,240 lbs	45,300 lbs	52,000 lbs	3/16" - SPIN RESISTANT (5:1 S.F.) 45,300-lbs. BREAKING STRENGTH

DEDUCTIONS FROM RATED LOADS FOR HANDLING DEVICES SUPPLIED BY ELLIOTT EQUIPMENT CO.

OVERHAUL BALL ----- SEE OVERHAUL BALL MFR. NAMEPLATE  
LOAD BLOCK ----- SEE BLOCK MFR. NAMEPLATE

#### BOOM LOAD RATINGS

LOAD RATINGS IN LBS. WITH OUTRIGGERS FULLY EXTENDED HORIZONTALLY AND VERTICALLY

LOAD RADIUS IN FEET	LOADED BOOM ANGLE	31-FT.	46-FT.	58-FT.	70-FT.	82-FT.	94-FT.	105-FT.
5	80	52,000						
6	78	44,000						
8	74	36,600	79.5	30,000				
10	70	31,000	77	27,000	80	20,000		
12	66	26,500	74.5	24,900	78	19,800		
14	61.5	20,500	72	21,800	76	17,700	79.5	18,500
16	57	18,500	69	19,500	74	16,000	77.5	16,000
18	52	15,900	66	15,800	72	14,400	76	14,800
20	47	14,300	63	12,800	69.5	11,500	74	13,400
25	30.5	10,300	55.5	11,000	64.5	9,500	69.5	10,900
30			47.5	9,300	58.5	7,950	65.5	9,000
35			37.5	8,500	52.5	6,700	60.5	7,500
40			23	6,300	45.5	5,600	55.5	6,300
45					37	4,000	50	5,300
50					26.5	3,850	44	4,600
55							37	3,800
60							28.5	2,700
65							15.5	2,150
70								30
75								20.5
80								
85								
90								
0		5,500	0	2,900	0	1,100	0	500
DEDUCTIONS FOR STOWED JIB (lbs)		850	600	450	400	350	300	250
DEDUCTIONS FOR STOWED FIXED LENGTH JIB (lbs)		550	350	300	250	200	150	150

#### JIB LOAD RATINGS

LOAD RATINGS IN LBS WITH OUTRIGGERS AND STABILIZERS EXTENDED

26-ft FIXED LENGTH JIB			26'-45' TWO SECTION JIB			
			RETRACTED 26' JIB		EXTENDED 45' JIB	
LOAD RADIUS IN FEET	LOADED BOOM ANGLE	26-ft JIB	LOAD RADIUS IN FEET	LOADED BOOM ANGLE	26-ft JIB	45-ft JIB
30	78.5	4,400	30	78.5	4,150	
35	76.5	4,000	35	76	3,750	77
40	74	3,600	40	74	3,350	75.5
45	72	3,100	45	71.5	2,850	74
50	69.5	2,700	50	69	2,450	72
55	67	2,300	55	66.5	2,050	70
60	64.5	2,000	60	64	1,750	68
65	62	1,700	65	61.5	1,450	66
70	59	1,500	70	59	1,250	64
75	56.5	1,300	75	56	1,050	61.5
80	53.5	1,100	80	53.5	850	59.5
85	50.5	900	85	50.5	650	57
90	47.5	700	90			55
			95			52

#### AREA OF OPERATION

LINE THROUGH CENTERLINE OF ROTATION

A FRONT CENTER STABILIZER IS REQUIRED FOR 360° AREA OF OPERATION.

180° FULL CAPACITY WORK AREA

OPTIONAL 360° WORK AREA OPERATION

DEDUCTIONS FOR STOWED EXTENDABLE JIB (lbs)

DEDUCTIONS FOR STOWED FIXED LENGTH JIB (lbs)

NOTE: 1. CAPACITIES DO NOT EXCEED 118% STABILITY. 2. PERSONNEL HANDLING IS ALLOWED ONLY WITH FULL SPAN OUTRIGGERS. 3. LOAD RATINGS ABOVE BOLD LINE ARE STRUCTURALLY LIMITED. 4. BOOM LOAD RATINGS ARE BASED ON LOADED BOOM RADIUS. 5. LOADED BOOM ANGLES ARE GIVEN AS A REFERENCE ONLY.

CRANE MEETS ASME B30.5 REQUIREMENTS AT TIME OF MANUFACTURE. DO NOT PAINT OVER ANY LABELS 1113570 111308

DIGGER RANGE CHART - FULL-SPAN OUTRIGGERS

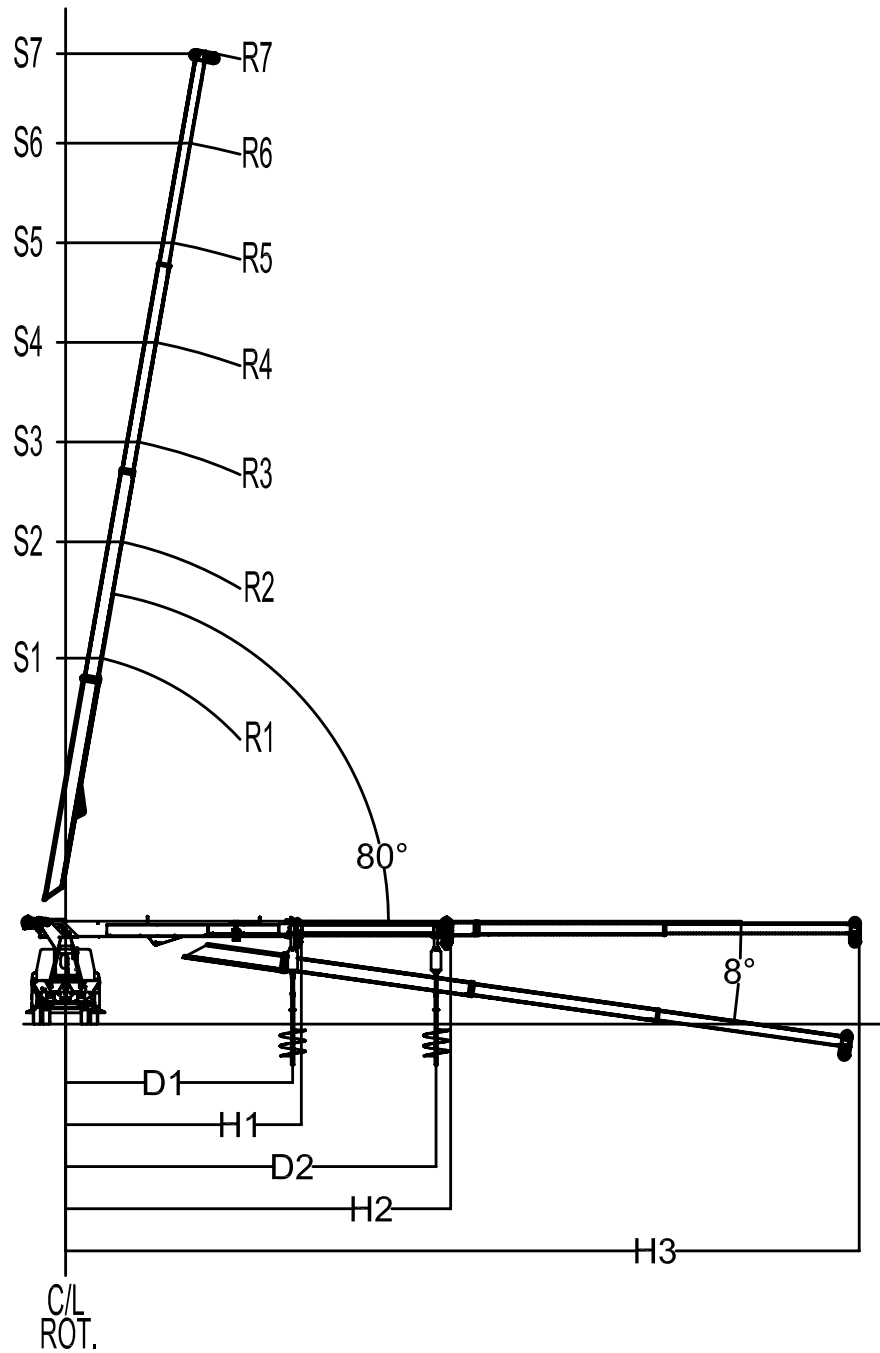

**DIGGING RANGE DATA (REFERENCE PREVIOUS PAGE)**

**CAPACITIES & DIMENSIONAL DATA**

<b>MODEL</b>	<b>30105F-D</b>	<b>3095F-D</b>	<b>26105F-D</b>	<b>2695F-D</b>
<b>MAX CAPACITY</b>	60,000 LB	60,000 LB	52,000 LB	52,000 LB
<b>CAPACITY @ 10 FT RADIUS</b>	30,650 LB	35,600 LB	29,650 LB	33,700 LB
<b>SHEAVE HEIGHT</b>				
<b>S1</b>	43 FT	40 FT	44 FT	41 FT
<b>S2</b>	58 FT	56 FT	59 FT	55 FT
<b>S3</b>	70 FT	67 FT	71 FT	68 FT
<b>S4</b>	82 FT	80 FT	83 FT	81 FT
<b>S5</b>	93 FT	93 FT	94 FT	94 FT
<b>S6</b>	105 FT	105 FT	106 FT	106 FT
<b>S7</b>	115 FT		116 FT	
<b>LOAD RADIUS</b>				
<b>R1</b>	31 FT	28 FT	31 FT	28 FT
<b>R2</b>	46 FT	43 FT	46 FT	43 FT
<b>R3</b>	58 FT	56 FT	58 FT	56 FT
<b>R4</b>	70 FT	69 FT	70 FT	69 FT
<b>R5</b>	82 FT	82 FT	82 FT	82 FT
<b>R6</b>	94 FT	95 FT	94 FT	95 FT
<b>R7</b>	105 FT		105 FT	
<b>HORIZONTAL REACH</b>				
<b>H1</b>	31 FT	28.5 FT	31 FT	28.5 FT
<b>H2</b>	48.5 FT	46 FT	48.5 FT	46 FT
<b>H3</b>	105 FT	95 FT	105 FT	95 FT
<b>DIGGING RADIUS</b>				
<b>D1</b>	27 FT	24.5 FT	27 FT	24.5 FT
<b>D2</b>	44 FT	41 FT	44 FT	41 FT

**TRUCK CHASSIS SPECIFICATIONS**

	26105F-D BoomTruck
Wheelbase (WB)	268" / 681 cm
Cab to Tandem (CT)	192" / 487 cm
Cab to End of Frame (EOF)	312" / 792 cm
Frame Section Modulus	30.0 in3-110,000 psi
Front Axle Gross Weight Rating	20,000 lb / 9071 kg
Rear Axle Gross Weight Rating	40,000 lb / 18 143 kg
Integral Front Frame Rails	Required for Front Stabilizer

Chassis data is minimum general requirements-not for engineering.  
 Actual dimensions and truck data will depend on truck selection and axle configuration.  
 \*Minimum chassis weight is required to meet 85% stability requirements.

**OPTIONS**



**Hydraulic Pole Claw**

Combine Elliott’s digger system with a hydraulic pole claw to dig holes and place poles with a single machine.



**Pin-On Jib Attachments**

One piece & two piece telescoping or fixed jibs that stow on the side of the boom for easy placement while on the worksite.

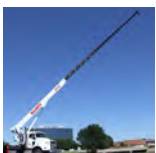

**Continuous Boom Rotation**

Add the convenience of 360 degree continuous rotation by adding a special boom rotation system for swinging without stops.



**Digger / Auger Flightings**

Dig faster and deeper with Elliott’s selection of auger flightings up to 48” in diameter that provide an industry-leading 44’ digging radius and more power out of the hole.



**Tool Boxes**

Optional tool boxes and bed storage can accommodate any storage need for tools, work materials and more.

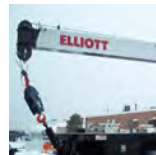

**Hook Block for Multi-Part Line**

Elliott can install a 2-3 part hook block or a 4 part-hook block to improve lifting capabilities. The block can be stored at the rear of the bed.



**Gravity Levelled Basket**

Elliott’s pin-on work platform pins onto the boom for easy installation and removal. Gravity leveling and mechanical rotation makes it a great accessory for any worksite.

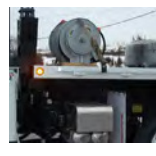

**Body Mounted Hose Reels and Circuits**

Let us work with you to customize your tool compatibility by adding hose reels or hydraulic circuits to the crane bed.

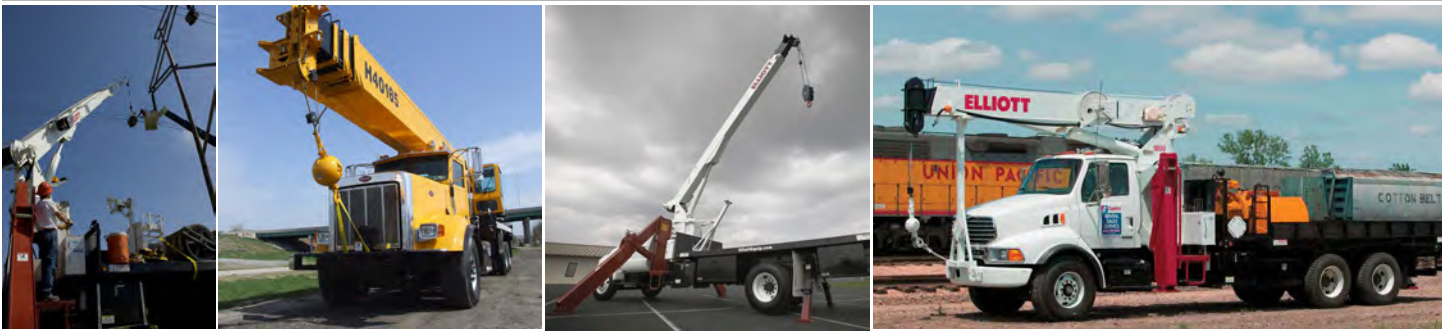

### 3095F SIDE VIEW DIAGRAM

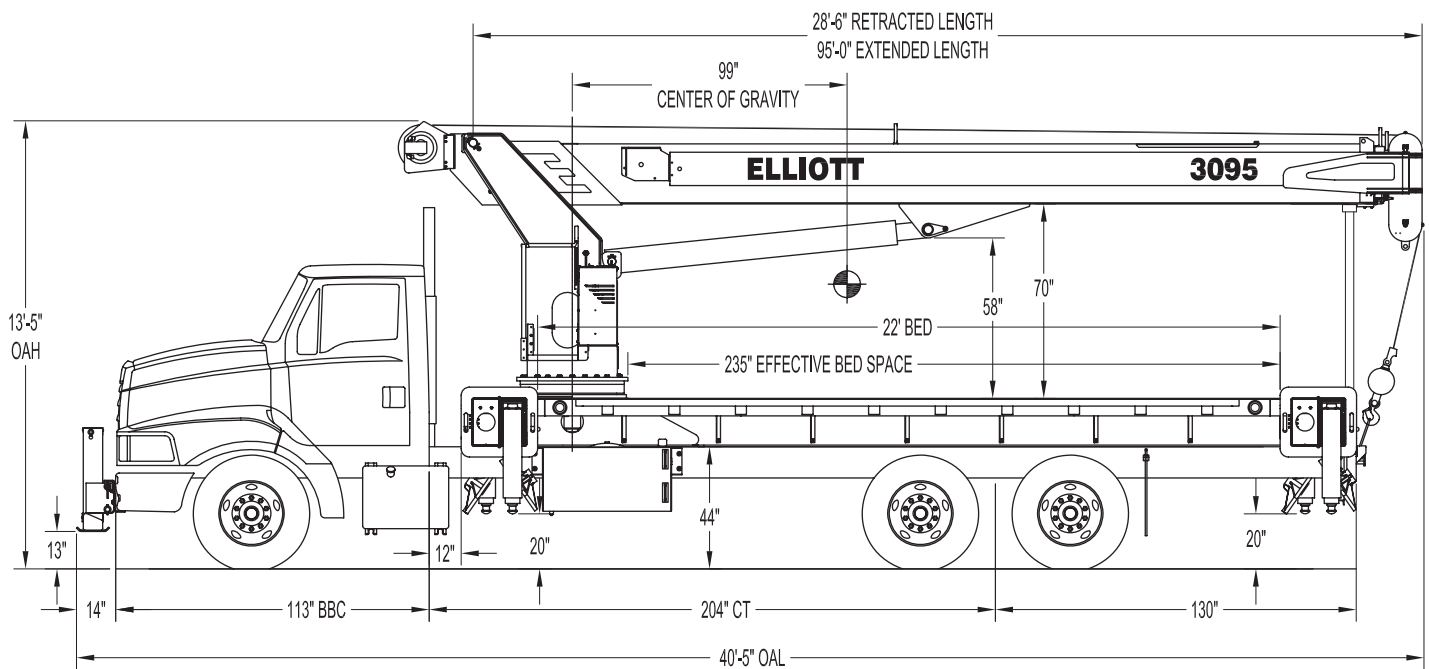

- |                                  |                                     |                                 |                  |
|----------------------------------|-------------------------------------|---------------------------------|------------------|
| • <b>Maximum Vertical Reach</b>  | 148'/45,1 m                         | • <b>Powered Boom Sections</b>  | 4                |
| • <b>Working Area</b>            | 180 Degrees Standard (360 Optional) | • <b>Overall Height</b>         | 13'5"/4,1 m      |
| • <b>Lifting Capacity</b>        | 60,000 lbs/27 215 kg                | • <b>Operator Controls</b>      | Rotating Standup |
| • <b>Boom Length</b>             | 95'/29 m                            | • <b>Outrigger Type Front</b>   | Out-Down         |
| • <b>Crane Weight (Standard)</b> | 27,750 lbs/12 587 kg                | • <b>Outrigger Spread Front</b> | 20'6 m           |
| • <b>Jib Lengths</b>             | 24'-41'/ 7,3-12,5 m                 | • <b>Outrigger Type Rear</b>    | Out-Down         |
| • <b>Winch Bare Drum Pull</b>    | 12,800 lbs/5806 kg                  | • <b>Outrigger Spread Rear</b>  | 20'6 m           |

## TECHNICAL SPECIFICATIONS

**Crane Capacity:** 60,000 lbs at 5' load radius.

**Maximum Tip Height:** 107' height (148' with optional 41' jib)

**Control Console:** Rotating turret single operator standup control station equipped with four single axis control levers for the main crane controls. Operator station includes LMI display, bubble level gauge, engine start/stop switch, signal horn button, variable speed throttle switch, lifting capacity chart, range diagram chart, boom angle indicator, system pressure gauge, 12V DC power source, and cup holder. Independent ground level electric operated outrigger controls.

**Boom:** Four-section fully proportional, high strength steel plated rectangular tube sections. A maximum boom tip height of 107' mounted on a truck. The boom nose contains one floating upper sheave and three lower sheaves. Assembly includes heavy-duty cylinder fittings, pivot pins, and replaceable wear pads.

**Winch:** Mounted at the base of the boom for a long fleet angle and flat level spooling of cable. Winch is driven by a planetary reducer and powered by a hydraulic motor. Burst-of-speed winch provides increased line speed. The winch brake is spring applied, pressure release design. Supplied with 425' of 9/16" diameter rotation resistant wire rope with a single line pull of 9,060 pounds, and a downhaul ball with swivel hook for single part line.

**Load Moment Indicator System:** System senses hoist cylinder pressures, boom length and boom angle with hydraulic function lockout. The display console is equipped with a bar graph showing crane utilization, boom angle or boom length, a mode select controls for main boom and jib operation, and an anti-two block with an audio/visual warning and shut-off functions to limit hook-boom point contact.

Elliott Equipment Company reserves the right to change the specification of any unit at any time without prior notice. This brochure is only a statement of general specifications on the date of this publication. For more detailed info on specific Elliott trucks go to [www.elliottequip.com](http://www.elliottequip.com)

**Outriggers:** Two sets of out and down overframe outriggers with 20' span. Outriggers are configured for full span, mid span, or retracted operation. Outriggers equipped with ball socket aluminum removable pads that stow on vertical outrigger legs.

**Frame:** Full length, all welded rigid 4-plate design sub-frame. Sub-frame allows for bolt-on addition of 22' bed wings, with top plate of subbase serving as a portion of the bed deck, to form a three-piece bed.

**Turret:** Reverse offset turret is one-piece weldment. Turret rotates on large diameter ball bearing.

**Rotation:** Hydraulic motor drives turret through double reduction planetary swing drive for 372-degree non-continuous rotation. The swing drive system has a spring applied, pressure release brake.

**Lift:** One double-acting long stroke cylinder provides smooth and stable boom elevation. Holding valve prevents boom from falling in event of hose failure.

**Boom Extension:** Incorporates a 2-stage hydraulic extension cylinder, attached to the largest boom section, with a proportional cable extension system driving the outermost sections.

**Hoses:** All high pressure hoses are wire braid reinforced with a minimum safety factor of 4 to 1.

**Cylinders:** All cylinders use microhoned cylinder tubing, chrome shafts, top grade packing and protective rod wipers. Cylinder-mounted holding valves provided on all load-holding cylinders.

**Hydraulic System:** Equipped with cable-shift PTO, piston pump, SAE O-ring face seals on pressure lines, and a 10-micron return line filter. The control valve distributes all flow to hoist system, swing circuit, and other crane functions. System is closed center type.

**Oil Tank Capacity:** 120 gallon mounted to truck frame on roadside.

**Cab Equipment:** PTO cable with indicator lights installed in truck cab. U/L approved 5:BC dry chemical fire extinguisher installed in truck cab.

**Operators Manual & Video:** Two CD copies and one hard copy of operation, maintenance, safety and parts manual provided with each unit. Operational and safety video provided at delivery.

**Installation:** Unit installed on chassis, painted, system and tank filled with oil, tested, inspected, and ready to operate.

**Standard Paint:** Paint turret and boom white, outriggers red, and bed and boxes black. Top of bed painted with black nonskid surface.

**Bumper:** Bureau of Motor Carrier Safety rear bumper.

**Weight:** Approximately 27,750 lbs. with 22' steel-floor bed less truck.

**Truck Chassis Required:** Approx. 204" C.T. RBM 3,300,000 in-lb. per rail, 20,000 lb. front axle and 40,000 lb. GVWR required. Trucks must have front frame extension, 12V electrical system with high capacity alternator, cab clearance stop/tail/backup lights, and I.D. lamps. Recommended GVWR is minimum for BoomTruck with flatbed only. Contact factory when additional equipment is to be added.

**Options:**

24' to 41' 2 Piece Telescopic Jib

Radio Remote Controls

Gravity-Leveled Steel Basket

Tool Box Configurations

Front Jack for 360 Degree Crane Operation

Much more...

**LOAD CHART - MAIN BOOM, FULL-SPAN OUTRIGGERS**



**MODEL 3000 95-ft BOOM**

**MAIN BOOM LOAD RATINGS WITH FULLY EXTENDED OUTRIGGERS**

**MAIN BOOM LOAD RATINGS**

LOAD RATINGS IN lbs WITH OUTRIGGERS AND STABILIZERS EXTENDED

LOAD RADIUS IN FEET	LOADED BOOM ANGLE	LOAD RATINGS IN lbs WITH OUTRIGGERS AND STABILIZERS EXTENDED										
		28-ft	43-ft	56-ft	69-ft	82-ft	95-ft	28-ft	43-ft	56-ft	69-ft	
5	79.5	60,000										
8	72.5	44,000	79.5	32,700								
10	68	37,000	76.5	31,500								
12	63	32,000	74	27,400	78.5	26,800						
14	58	28,100	71	25,400	76.5	24,900	79.5	22,200				
16	53	24,200	68	23,500	74	23,200	78	21,400	77.5	15,800		
20	40.5	20,100	62	19,300	70	19,500	74.5	18,200	74	13,700	79	10,700
25	10.5	14,900	53.5	15,600	64	15,000	70	14,600	70.5	11,800	76.5	10,500
30			43.5	12,300	57.5	12,100	65	11,900	66.5	9,700	73.5	9,400
35			32.5	9,200	51	10,000	60	9,900	62.5	8,300	70.5	8,400
40			7	6,200	44	8,350	55.5	8,300	58	5,700	67	7,350
45					35	6,050	49.5	6,000	53.5	4,700	64	6,950
50					22.5	4,900	43.5	4,950	48.5	4,050	59.5	4,650
55							36.5	4,100	42.2	3,400	56	4,050
60							27.5	3,350	37	2,850	52	3,450
65							13	2,650	30.5	2,350	47.5	2,850
70									21	1,950	43	2,350
75											38	1,950
80											32	1,550
85											25	1,250
90											14.5	950
0	10,000	0	7,600	0	4,350	0	2,600	0	1,550	0	800	
DEDUCTIONS FOR STOWED JIB (lb)	900		600		450		350		300		250	
	600		400		300		250		200		200	

**JIB LOAD RATINGS**

LOAD RATINGS IN lbs WITH OUTRIGGERS AND STABILIZERS EXTENDED

LOAD RADIUS IN FEET	LOADED BOOM ANGLE	LOAD RATINGS IN lbs WITH OUTRIGGERS AND STABILIZERS EXTENDED					
		24-ft FIXED LENGTH JIB			24-41 ft EXTENDABLE JIB		
		24-ft JIB	LOADED BOOM ANGLE	24-ft JIB RETRACTED	LOADED BOOM ANGLE	41-ft JIB EXTENDED	
30	74.5	5,450	74.5	5,200	76.5	3,200	
35	72	5,050	72	4,800	74.5	3,050	
40	69.5	4,600	69.5	4,350	72	2,850	
45	67	4,150	67	3,900	70	2,650	
50	64.5	3,750	64.5	3,500	67.5	2,450	
55	61.5	3,300	61.5	3,050	65.5	2,300	
60	58.5	2,800	58.5	2,550	63	2,150	
65	56	2,300	56	2,050	60.5	2,000	
70	53	1,850	53	1,600	58	1,850	
75	50	1,450	50	1,200	55.5	1,600	
80	46.5	1,100	46.5	850	53	1,350	
85	43	800	43	550	50.5	1,100	
90					47.5	850	
95					44.5	600	

ELLIOTT EQUIPMENT CO. SUPPLIED  
LOADLINE EQUIPMENT DEDUCTIONS:  
DOWNHAUL WEIGHT .....180 lbs  
ONE SHEAVE BLOCK.....375 lbs  
TWO SHEAVE BLOCK.....640 lbs  
THREE SHEAVE BLOCK.....870 lbs  
AUXILIARY SHEAVE.....100 lbs

DEDUCTIONS FOR STOWED EXTENDABLE JIB (lbs)

DEDUCTIONS FOR STOWED FIXED LENGTH JIB (lbs)

1-PART LINE	2-PART LINE	3-PART LINE	4-PART LINE	5-PART LINE	6-PART LINE	7-PART LINE	NOTICE
							-DO NOT DEADEND LINE BLOCK (SHORT) FROM TOP WHEN EXTENDING BOOM -KEEP AT LEAST 3 FEET OF LEADLINE ON THE WINCH DRUM AT ALL TIMES -USE ONLY 1/2" DIA. QUARTER WAVE ROPE AS SPECIFIED BELOW WITH THE PROPER BREAKING STRENGTHS LISTED -ANTI-BLOCK SYSTEM MUST BE USED -OPERATING CONFINED BEFORE OPERATING CRANE. SEE OPERATOR'S SAFETY MANUAL.
MAX PULL: 9,600 lbs	19,200 lbs	28,800 lbs	38,400 lbs	48,000 lbs	56,000 lbs	60,000 lbs	
MAX PULL: 9,060 lbs	18,120 lbs	27,180 lbs	36,240 lbs	45,300 lbs	54,360 lbs	60,000 lbs	

CRANE MEETS ASME B30.5 REQUIREMENTS AT TIME OF MANUFACTURE

DO NOT PRINT OVER AIR LABELS 115160 11/30



Elliott Equipment Company  
3514 South 25th Street  
Omaha, NE 68105  
Phone: 402-592-4500  
Fax: 402-592-4553  
Email: sales@elliottequip.com

**Built for You.**  
www.elliottequip.com

**LOAD CHART - MAIN BOOM, MID-SPAN OUTRIGGERS**



**MODEL 3000 95-ft BOOM**

**MAIN BOOM LOAD RATINGS WITH OUTRIGGERS AT MID-SPAN POSITION**

**MAIN BOOM LOAD RATINGS**

LOAD RATINGS IN lbs WITH OUTRIGGERS AND STABILIZERS EXTENDED

LOAD RADIUS IN FEET	LOADED BOOM ANGLE	28-ft	LOADED BOOM ANGLE	A 43-ft	LOADED BOOM ANGLE	B 56-ft	LOADED BOOM ANGLE	C 69-ft	LOADED BOOM ANGLE	D 82-ft	LOADED BOOM ANGLE	E 95-ft
5	79.5	60,000										
8	72.6	44,000	79.5	32,700								
10	68	37,000	76.6	31,500								
12	63.2	32,000	74	27,400	78.4	26,800						
14	58.1	28,100	71	25,400	76.3	24,900	79.6	22,200				
16	52.7	21,400	68	21,400	74	21,400	78	21,400				
20	40.2	13,700	61.5	13,700	69.2	13,700	74	13,700	77.3	13,700	79.1	10,700
25	16.3	9,000	53.5	9,000	63.7	9,000	69.5	8,950	73.5	8,950	76.4	10,000
30			43.9	6,300	57.4	6,300	65	6,300	69.5	6,300	73.1	7,250
35			31.8	4,550	50.7	4,550	60	4,550	65.4	4,550	69.7	5,500
40			7.1	3,000	43.1	3,350	54.5	3,550	61.2	3,350	65.8	3,200
45					34.1	2,500	49	2,500	57	2,500	62.2	2,400
50					22	1,850	43	1,850	52.4	1,800	58.6	2,000
55							35.5	1,300	47.5	1,300	54.9	1,600
60							27	900	42.3	850	50.9	1,250
65							12.3	500	36.5	500	46.7	950
70											42.1	750
DEDUCTIONS FOR STOWED JIB (lb)		900		600		450		350		300		250
		600		400		300		250		200		200

**JIB LOAD RATINGS**

LOAD RATINGS IN lbs WITH OUTRIGGERS AND STABILIZERS EXTENDED

LOAD RADIUS IN FEET	LOADED BOOM ANGLE	24-ft FIXED LENGTH JIB		24-41 ft EXTENDABLE JIB		
		24-ft JIB	LOADED BOOM ANGLE	24-ft JIB RETRACTED	LOADED BOOM ANGLE	41-ft JIB EXTENDED
30	74.5	5,450	74.5	5,200	76.5	3,200
35	72	4,000	72	3,600	74.5	3,050
40	69.5	2,800	69.5	2,400	72	2,850
45	67	1,950	67	1,600	70	2,650
50	64.5	1,300	64.5	900	67.5	2,150
55	61.5	750			65.5	1,300

ELLIOTT EQUIPMENT CO. SUPPLIED  
 LOADLINE EQUIPMENT DEDUCTIONS:  
 DOWNHAUL WEIGHT .....180 lbs  
 ONE SHEAVE BLOCK.....375 lbs  
 TWO SHEAVE BLOCK.....640 lbs  
 THREE SHEAVE BLOCK.....870 lbs  
 AUXILIARY SHEAVE.....100 lbs

DEDUCTIONS FOR STOWED EXTENDABLE JIB (lbs)

DEDUCTIONS FOR STOWED FIXED LENGTH JIB (lbs)

**1-PART LINE**



MAX PULL: 9,600 lbs

MAX PULL: 9,060 lbs

**2-PART LINE**



19,200 lbs

18,120 lbs

**3-PART LINE**



28,800 lbs

27,180 lbs

**4-PART LINE**



38,400 lbs

36,240 lbs

**5-PART LINE**



48,000 lbs

45,300 lbs

**6-PART LINE**



56,000 lbs

54,360 lbs

**7-PART LINE**



60,000 lbs

60,000 lbs

**NOTICE**

- DO NOT DEADHEAD LINE BLOCK AGAINST BOOM TIP WHEN EXTENDING BOOM.
- KEEP AT LEAST 5 WRAPS OF LOADLINE ON THE WINCH DRUM AT ALL TIMES.
- USE ONLY 9/16" DIAMETER WIRE ROPE, AS SPECIFIED BELOW, WITH THE PROPER BREAKING STRENGTHS LISTED.
- ANTI-TWO-BLOCK SYSTEM MUST BE IN GOOD OPERATING CONDITION BEFORE OPERATING CRANE. SEE OPERATION & SAFETY MANUAL.

9/16" - 6 x 37 IWRC (3.5:1 S.F.)  
 33,600-lbs, BREAKING STRENGTH  
 9/16" - SPIN RESISTANT (5:1 S.F.)  
 45,300-lbs, BREAKING STRENGTH

CRANE MEETS ASME B30.5 REQUIREMENTS AT TIME OF MANUFACTURE

DO NOT PAINT OVER ANY LABELS

1113160 111308



Elliott Equipment Company  
 3514 South 25th Street  
 Omaha, NE 68105

Phone: 402-592-4500  
 Fax: 402-592-4553  
 Email: sales@elliottequip.com

**Built for You.**  
 www.elliottequip.com

**LOAD CHART - MAIN BOOM, RETRACTED OUTRIGGERS**



**MODEL 3000**

**95-ft BOOM**

**MAIN BOOM LOAD RATINGS WITH OUTRIGGERS AT FULL HORIZONTAL RETRACTED POSITION**

**MAIN BOOM LOAD RATINGS**

LOAD RATINGS IN lbs WITH OUTRIGGERS AND STABILIZERS EXTENDED

LOAD RADUIS IN FEET	LOADED BOOM ANGLE	LOAD RATINGS IN lbs WITH OUTRIGGERS AND STABILIZERS EXTENDED										
		28-ft	LOADED BOOM ANGLE	A 43-ft	LOADED BOOM ANGLE	B 56-ft	LOADED BOOM ANGLE	C 69-ft	LOADED BOOM ANGLE	D 82-ft	LOADED BOOM ANGLE	E 95-ft
5	79.5	60,000										
8	72.5	22,000	78.9	22,000								
10	67.5	14,900	76.1	14,900								
12	62.8	10,800	73.5	10,800	77.5	10,800						
14	58.9	8,200	70.7	8,200	75.6	8,200	78.7	8,200				
16	53.7	6,500	67.7	6,500	73.5	6,500	76.9	6,500	79.5	6,500		
20	41.6	4,400	61.5	4,400	68.9	4,400	73.5	4,400	76.3	4,400	78.3	4,400
25	16.5	2,550	53.1	2,550	63.1	2,550	68.7	2,550	72.5	2,550	74.9	2,550
30			43.6	1,450	56.8	1,450	63.9	1,450	68.5	1,450	71.6	1,450
35			31.6	700	50.1	700	59.1	700	64.6	700	68.5	700
DEDUCTIONS FOR STOWED JIB (lb)		900		600		450		350		300		250
		600		400		300		250		200		200

ELLIOTT EQUIPMENT CO. SUPPLIED  
 LOADLINE EQUIPMENT DEDUCTIONS:  
 DOWNHAUL WEIGHT .....180 lbs  
 ONE SHEAVE BLOCK.....375 lbs  
 TWO SHEAVE BLOCK.....640 lbs  
 THREE SHEAVE BLOCK.....870 lbs  
 AUXILIARY SHEAVE.....100 lbs

DEDUCTIONS FOR STOWED EXTENDABLE JIB (lbs)

DEDUCTIONS FOR STOWED FIXED LENGTH JIB (lbs)

1-PART LINE	2-PART LINE	3-PART LINE	4-PART LINE	5-PART LINE	6-PART LINE	7-PART LINE	NOTICE
							- DO NOT DEADHEAD LINE BLOCK AGAINST BOOM TIP WHEN EXTENDING BOOM. - KEEP AT LEAST 5 WRAPS OF LOADLINE ON THE WINCH DRUM AT ALL TIMES. - USE ONLY 9/16" DIAMETER WIRE ROPE, AS SPECIFIED BELOW, WITH THE PROPER BREAKING STRENGTHS LISTED. - ANTI-TWO-BLOCK SYSTEM MUST BE IN GOOD OPERATING CONDITION BEFORE OPERATING CRANE. SEE OPERATION & SAFETY MANUAL.
MAX PULL: 9,600 lbs	19,200 lbs	28,800 lbs	38,400 lbs	48,000 lbs	56,000 lbs	60,000 lbs	
MAX PULL: 9,060 lbs	18,120 lbs	27,180 lbs	36,240 lbs	45,300 lbs	54,360 lbs	60,000 lbs	9/16" - 6 x 37 IWRC (3.51 S.F.) 33,600-lbs, BREAKING STRENGTH 9/16" - SPIN RESISTANT (5:1 S.F.) 45,300-lbs, BREAKING STRENGTH

CRANE MEETS ASME B30.5 REQUIREMENTS AT TIME OF MANUFACTURE

DO NOT PAINT OVER ANY LABELS

1113160 111308



Elliott Equipment Company  
 4427 South 76th Circle  
 Omaha, NE 68127  
 Phone: 402-592-4500  
 Fax: 402-592-4553  
 Email: sales@elliottequip.com

**Built for You.**  
 www.elliottequip.com

**RANGE CHART - MAIN BOOM + JIB, FULL-SPAN OUTRIGGERS**



**MODEL 3000 95-ft BOOM**

**RANGE DIAGRAM WITH FULL SPAN OUTRIGGERS**

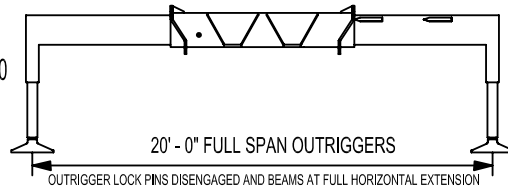
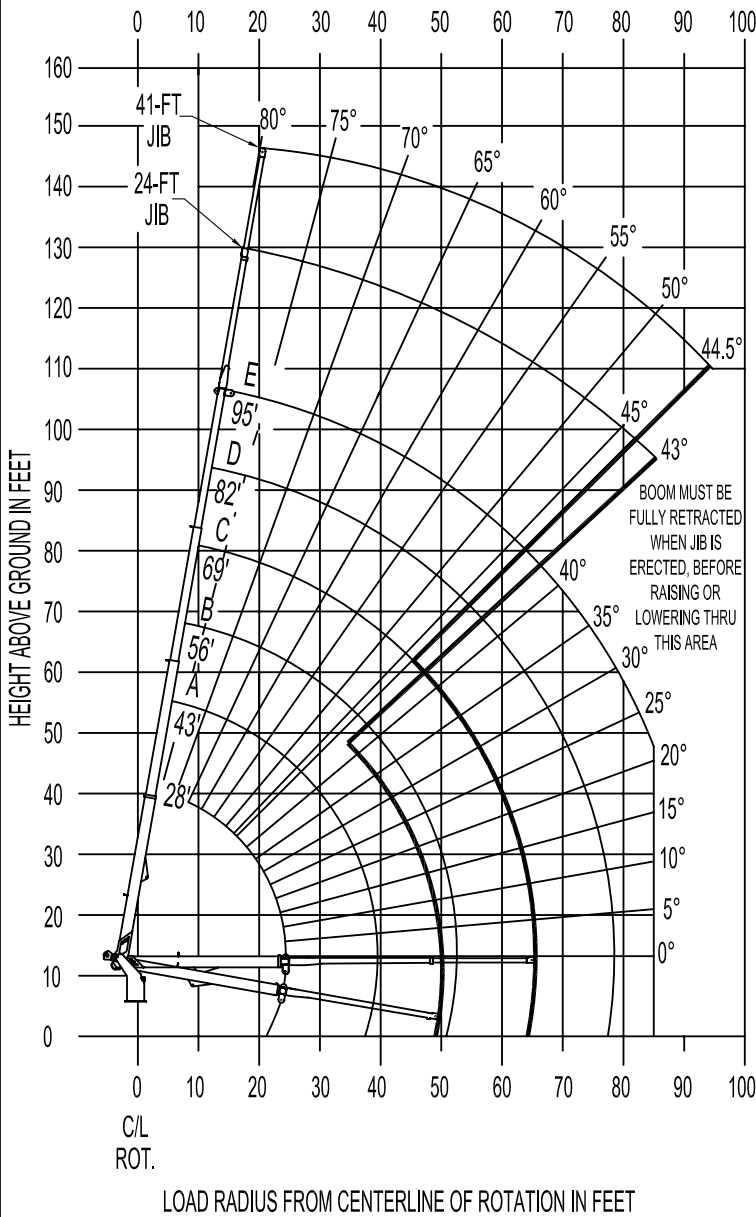

**NOTE:**

1. Operate jib by radius when main boom is full extended. Increase boom angle if necessary to maintain load radius.
2. When boom is retracted, operate jib by boom angles. Do not exceed any rated jib capacities at reduced boom lengths.
3. Capacities do not exceed 85% stability.
4. Load ratings above bold line are structurally limited.
5. Personnel handling is allowed only with full span outriggers.
6. Boom load ratings are based on loaded boom radius. Loaded boom angles are given as reference only.

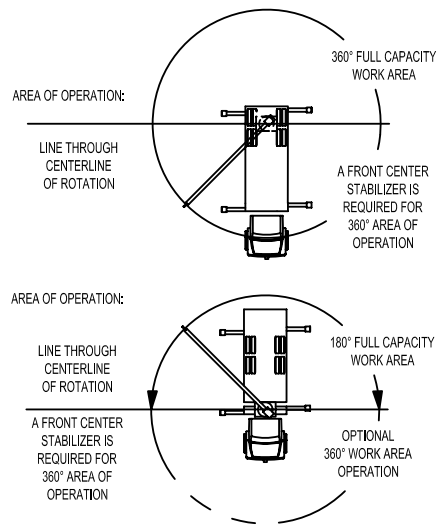

DO NOT PAINT OVER ANY LABELS 1113160 111308

**RANGE CHART - MAIN BOOM + JIB, MID-SPAN OUTRIGGERS**



**MODEL 3000 95-ft BOOM**

**RANGE DIAGRAM WITH OUTRIGGERS AT MID-SPAN POSITION**

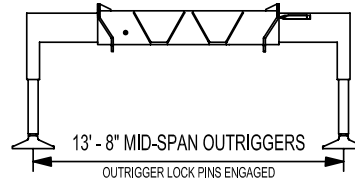
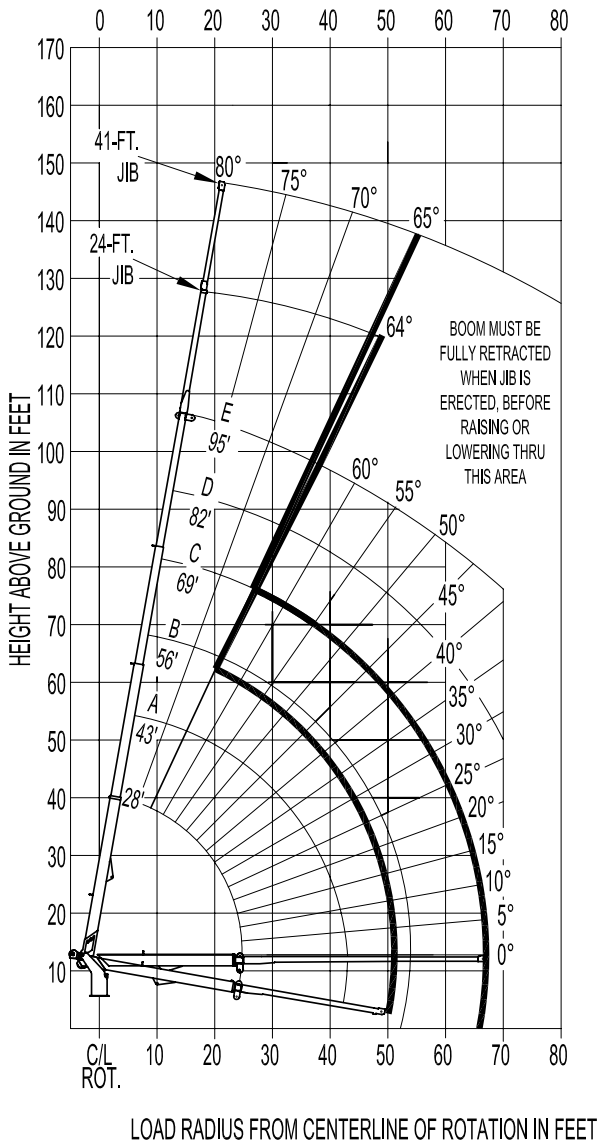

**NOTE:**

1. Operate jib by radius when main boom is full extended. Increase boom angle if necessary to maintain load radius.
2. When boom is retracted, operate jib by boom angles. Do not exceed any rated jib capacities at reduced boom lengths.
3. Capacities do not exceed stability based on ISO 4305-1991.
4. Load ratings above bold line are structurally limited.
5. Personnel handling is allowed only with full span outriggers.
6. Boom load ratings are based on loaded boom radius. Loaded boom angles are given as reference only.

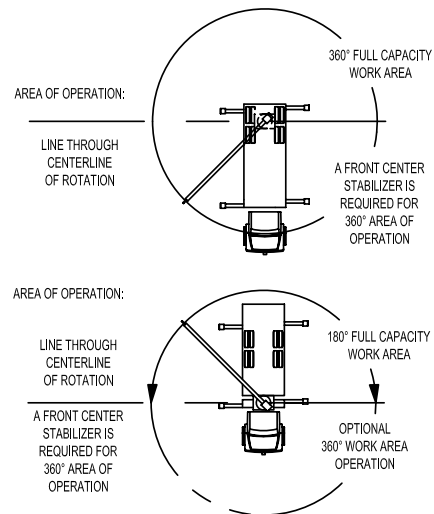

DO NOT PAINT OVER ANY LABELS 1113160 111308

**RANGE CHART - MAIN BOOM, RETRACTED OUTRIGGERS**



**MODEL 3000**

**95-ft BOOM**

**RANGE DIAGRAM WITH OUTRIGGERS  
AT FULL HORIZONTAL RETRACTED POSITION**

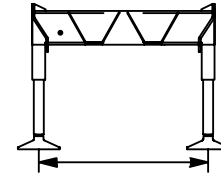
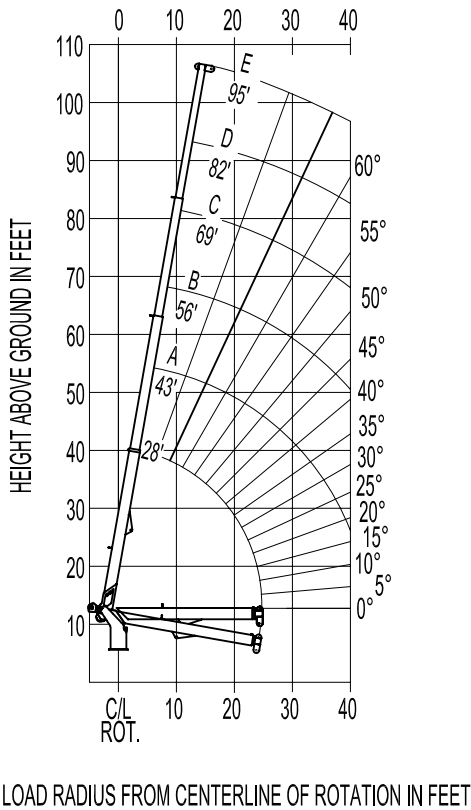

**7' - 5" NO-SPAN OUTRIGGERS**

**NOTE:**

1. Capacities do not exceed stability based on ISO 4305-1991.
2. Load ratings above bold line are structurally limited.
3. Personnel handling is allowed only with full span outriggers.
4. Boom load ratings are based on loaded boom radius.  
Loaded boom angles are given as reference only.

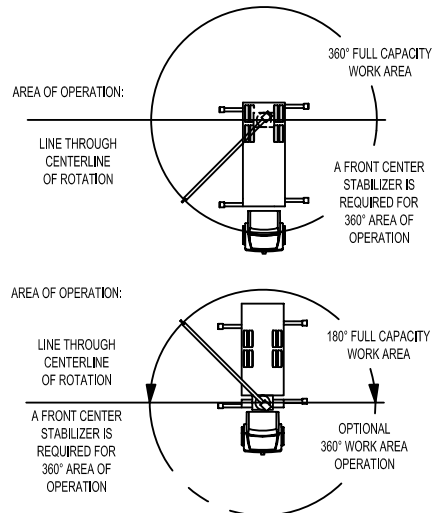

DO NOT PAINT OVER ANY LABELS 1113160 111308

**TRUCK CHASSIS SPECIFICATIONS**

	3095F BoomTruck
Wheelbase (WB)	268" / 681 cm
Cab to Tandem (CT)	204" / 518 cm
Cab to End of Frame (EOF)	334" / 848 cm
Frame Section Modulus	30.0 in3-110,000 psi / 492 cm3-758 428 kPa
Front Axle Gross Weight Rating	20,000 lb / 9072 kg
Rear Axle Gross Weight Rating	40,000 lb / 18 144 kg
Integral Front Frame Rails	Required for Front Stabilizer

Chassis data is minimum general requirements-not for engineering.  
 Actual dimensions and truck data will depend on truck selection and axle configuration.  
 \*Minimum chassis weight is required to meet 85% stability requirements.

**OPTIONS**



**Radio Remote Control**

Interference protected radio remotes let you get closer to your work and have full control over your machine. Includes battery charging feature and optional LMI screen.



**Tool Boxes**

Optional tool boxes and bed storage can accommodate any storage need for tools, work materials and more.



**Pin-On Jib Attachments**

One piece & two piece telescoping or fixed jibs that stow on the side of the boom for easy placement while on the worksite.

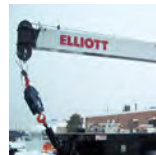

**Hook Block for Multi-Part Line**

Elliott can install a 2-3 part hook block or a 4 part-hook block to improve lifting capabilities. The block can be stored at the rear of the bed.



**Continuous Boom Rotation**

Add the convenience of 360 degree continuous rotation by adding a special boom rotation swivel for swinging without stops.



**Gravity Levelled Basket**

Elliott's pin-on work platform pins onto the boom for easy installation and removal. Gravity leveling and mechanical rotation makes it a great accessory for any worksite.



**Digger / Auger Attachment**

Dig faster and deeper with Elliott's auger attachment, offering 41' of digging range and a hydraulically powered auger that stows on the boom.

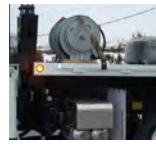

**Body Mounted Hose Reels and Circuits**

Let us work with you to customize your tool compatibility by adding hose reels or hydraulic circuits to the crane bed.

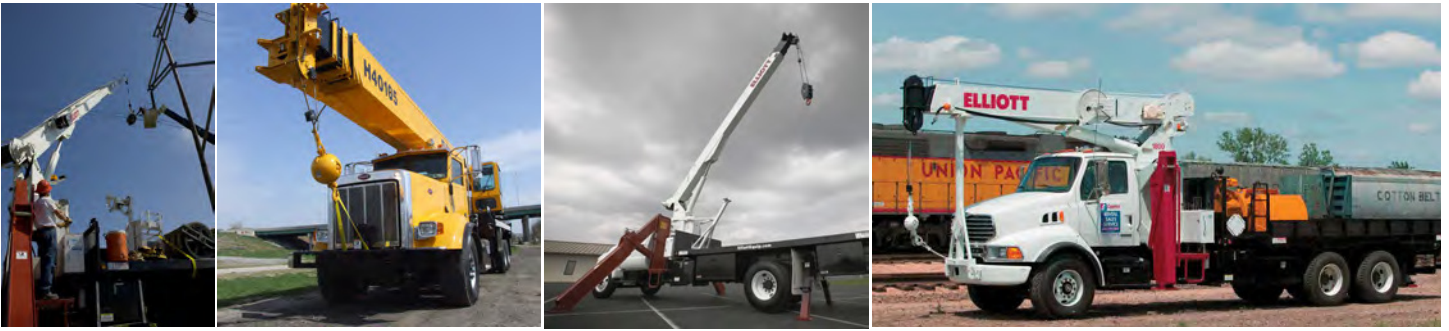

### 3095R SIDE VIEW DIAGRAM

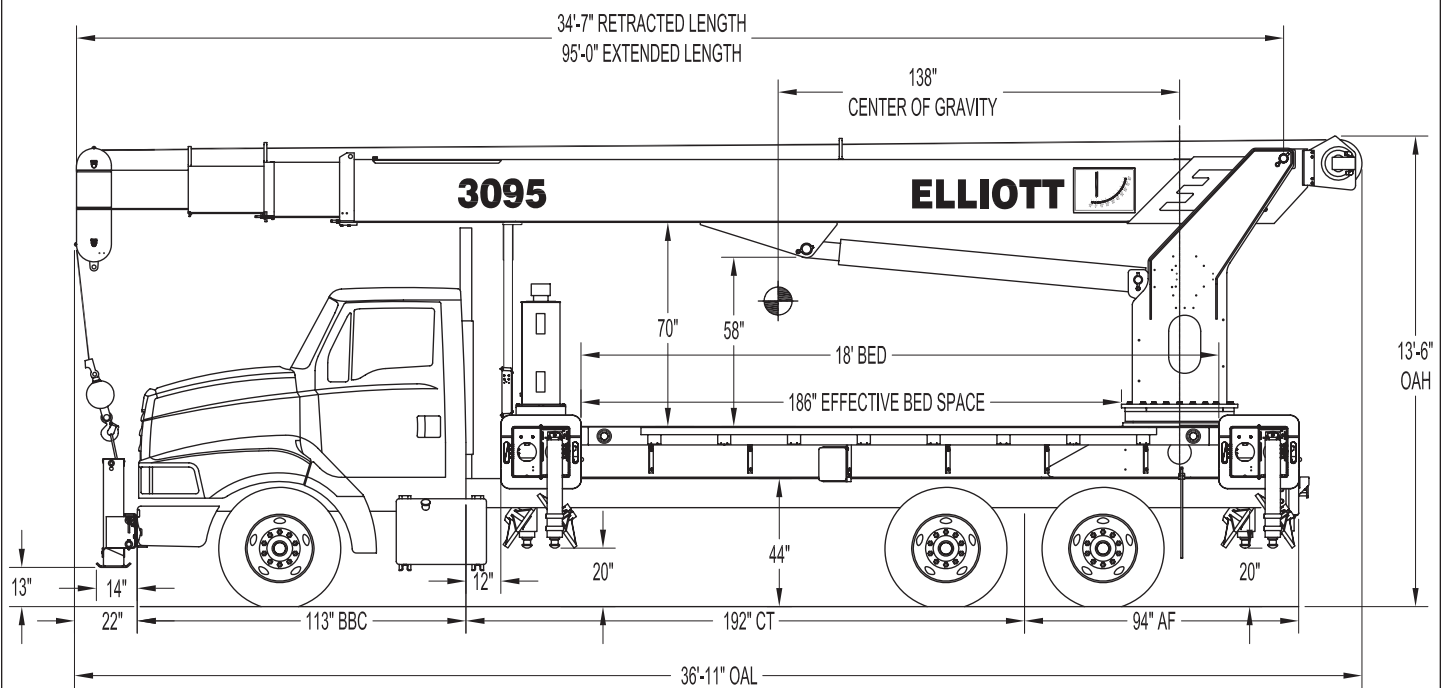

- |                                  |                       |                                 |                         |
|----------------------------------|-----------------------|---------------------------------|-------------------------|
| • <b>Maximum Vertical Reach</b>  | 148'/45,1 m           | • <b>Powered Boom Sections</b>  | 4                       |
| • <b>Working Area</b>            | 360 Degrees           | • <b>Overall Height</b>         | 13'6"/4,1 m             |
| • <b>Lifting Capacity</b>        | 60,000 lbs/27 216 kg  | • <b>Operator Controls</b>      | Rotating Standup or Cab |
| • <b>Boom Length</b>             | 95'/29 m              | • <b>Outrigger Type Front</b>   | Out-Down                |
| • <b>Crane Weight (Standard)</b> | 27,750 lbs/12 587 kg  | • <b>Outrigger Spread Front</b> | 20'6 m                  |
| • <b>Jib Lengths</b>             | 24', 41' / 7,3,12,5 m | • <b>Outrigger Type Rear</b>    | Out-Down                |
| • <b>Winch Bare Drum Pull</b>    | 12,800 lbs/5806 kg    | • <b>Outrigger Spread Rear</b>  | 20'6 m                  |

## TECHNICAL SPECIFICATIONS

**Crane Capacity:** 60,000 lbs at 5' load radius.

**Maximum Tip Height:** 107' height (148' with optional 41' jib)

**Control Console:** Rotating single operator standup control station or cab on turret equipped with four single axis control levers for the main crane controls. Operator station includes LMI display, bubble level gauge, engine start/stop switch, signal horn button, variable speed throttle switch, lifting capacity chart, range diagram chart, boom angle indicator, system pressure gauge, 12V DC power source, and cup holder. Independent ground level electric operated outrigger controls.

**Boom:** Four-section fully proportional, high strength steel plated rectangular tube sections. A maximum boom tip height of 107' mounted on a truck. The boom nose contains one floating upper sheave and three lower sheaves. Assembly includes heavy-duty cylinder fittings, pivot pins, and replaceable wear pads.

**Winch:** Mounted at the base of the boom for a long fleet angle and flat level spooling of cable. Winch is driven by a planetary reducer and powered by a hydraulic motor. Burst-of-speed winch provides increased line speed. The winch brake is spring applied, pressure release design. Supplied with 425' of 9/16" diameter rotation resistant wire rope with a single line pull of 9,060 pounds, and a downhaul ball with swivel hook for single part line.

**Load Moment Indicator System:** System senses hoist cylinder pressures, boom length and boom angle with hydraulic function lockout. The display console is equipped with a bar graph showing crane utilization, boom angle or boom length, a mode select controls for main boom and jib operation, and an anti-two block with an audio/visual warning and shut-off functions to limit hook-boom point contact.

Elliott Equipment Company reserves the right to change the specification of any unit at any time without prior notice. This brochure is only a statement of general specifications on the date of this publication. For more detailed info on specific Elliott trucks go to [www.elliottequip.com](http://www.elliottequip.com)

**Outriggers:** Two sets of out and down overframe outriggers with 20' span. Outriggers are configured for full span, mid span, or retracted operation. Outriggers equipped with ball socket aluminum removable pads that stow on vertical outrigger legs. Front stabilizer for 360 degree area of operation.

**Frame:** Full length, all welded rigid 4-plate design sub-frame. Sub-frame allows for bolt-on addition of 18' bed wings, with top plate of subbase serving as a portion of the bed deck, to form a three-piece bed.

**Turret:** Reverse offset turret is one-piece weldment. Turret rotates on large diameter ball bearing.

**Rotation:** Hydraulic motor drives turret through double reduction planetary swing drive for continuous rotation. The swing drive system has a spring applied, pressure release brake.

**Lift:** One double-acting long stroke cylinder provides smooth and stable boom elevation. Holding valve prevents boom from falling in event of hose failure.

**Boom Extension:** Incorporates a 2-stage hydraulic extension cylinder, attached to the largest boom section, with a proportional cable extension system driving the outermost sections.

**Hoses:** All high pressure hoses are wire braid reinforced with a minimum safety factor of 4 to 1.

**Cylinders:** All cylinders use microhoned cylinder tubing, chrome shafts, top grade packing and protective rod wipers. Cylinder-mounted holding valves provided on all load-holding cylinders.

**Hydraulic System:** Equipped with cable-shift PTO, piston pump, SAE O-ring face seals on pressure lines, and a 10-micron return line filter. The control valve distributes all flow to hoist system, swing circuit, and other crane functions. System is closed center type.

**Oil Tank Capacity:** 143 gallon mounted on top of truck frame.

**Cab Equipment:** PTO cable with indicator lights installed in truck cab. U/L approved 5:BC dry chemical fire extinguisher installed in truck cab.

**Operators Manual & Video:** Two CD copies and one hard copy of operation, maintenance, safety and parts manual provided with each unit. Operational and safety video provided at delivery.

**Installation:** Unit installed on chassis, painted, system and tank filled with oil, tested, inspected, and ready to operate.

**Standard Paint:** Paint turret and boom white, outriggers red, and bed and boxes black. Top of bed painted with black nonskid surface.

**Bumper:** Bureau of Motor Carrier Safety rear bumper.

**Weight:** Approximately 27,750 lbs. with 18' steel-floor bed less truck.

**Truck Chassis Required:** Approx. 192" C.T. RBM 3,300,000 in-lb. per rail, 20,000 lb. front axle and 40,000 lb. GVWR required. Trucks must have front frame extension, 12V electrical system with high capacity alternator, cab clearance stop/tail/backup lights, and I.D. lamps. Recommended GVWR is minimum for BoomTruck with flatbed only. Contact factory when additional equipment is to be added.

**Options:**

24' or 41' Fixed Jib.

Radio Remote Controls.

Gravity-Leveled Steel Basket.

Tool Box Configurations.

Much More...

**LOAD CHART - MAIN BOOM, FULL-SPAN OUTRIGGERS**



**MODEL 3000 95-ft BOOM**

**MAIN BOOM LOAD RATINGS WITH FULLY EXTENDED OUTRIGGERS**

**MAIN BOOM LOAD RATINGS**

LOAD RATINGS IN lbs WITH OUTRIGGERS AND STABILIZERS EXTENDED

LOAD RADIUS IN FEET	LOADED BOOM ANGLE	28-ft	LOADED BOOM ANGLE	A 43-ft	LOADED BOOM ANGLE	B 56-ft	LOADED BOOM ANGLE	C 69-ft	LOADED BOOM ANGLE	D 82-ft	LOADED BOOM ANGLE	E 95-ft
5	79.5	60,000										
8	72.5	44,000	79.5	32,700								
10	68	37,000	76.5	31,500								
12	63	32,000	74	27,400	78.5	26,800						
14	58	28,100	71	25,400	76.5	24,900	79.5	22,200				
16	53	24,200	68	23,500	74	23,200	78	21,400	77.5	15,800		
20	40.5	20,100	62	19,300	70	19,500	74.5	18,200	74	13,700	79	10,700
25	10.5	14,900	53.5	15,600	64	15,000	70	14,600	70.5	11,800	76.5	10,500
30			43.5	12,300	57.5	12,100	65	11,900	66.5	9,700	73.5	9,400
35			32.5	9,200	51	10,000	60	9,900	62.5	8,300	70.5	8,400
40			7	6,200	44	8,350	55.5	8,300	58	5,700	67	7,350
45					35	6,050	49.5	6,000	53.5	4,700	64	6,950
50					22.5	4,900	43.5	4,950	48.5	4,050	59.5	4,650
55							36.5	4,100	42.2	3,400	56	4,050
60							27.5	3,350	37	2,850	52	3,450
65							13	2,650	30.5	2,350	47.5	2,850
70									21	1,950	43	2,350
75											38	1,950
80											32	1,550
85											25	1,250
90											14.5	950
	0	10,000	0	7,600	0	4,350	0	2,600	0	1,550	0	800
DEDUCTIONS FOR STOWED JIB (lb)	900		600		450		350		300		250	
	600		400		300		250		200		200	

**JIB LOAD RATINGS**

LOAD RATINGS IN lbs WITH OUTRIGGERS AND STABILIZERS EXTENDED

LOAD RADIUS IN FEET	LOADED BOOM ANGLE	24-ft FIXED LENGTH JIB		24-41 ft EXTENDABLE JIB	
		24-ft JIB	LOADED BOOM ANGLE	24-ft JIB RETRACTED	LOADED BOOM ANGLE 41-ft JIB EXTENDED
30	74.5	5,450	74.5	5,200	76.5 3,200
35	72	5,050	72	4,800	74.5 3,050
40	69.5	4,600	69.5	4,350	72 2,850
45	67	4,150	67	3,900	70 2,650
50	64.5	3,750	64.5	3,500	67.5 2,450
55	61.5	3,300	61.5	3,050	65.5 2,300
60	58.5	2,800	58.5	2,550	63 2,150
65	56	2,300	56	2,050	60.5 2,000
70	53	1,850	53	1,600	58 1,850
75	50	1,450	50	1,200	55.5 1,600
80	46.5	1,100	46.5	850	53 1,350
85	43	800	43	550	50.5 1,100
90					47.5 850
95					44.5 600

ELLIOTT EQUIPMENT CO. SUPPLIED  
LOADLINE EQUIPMENT DEDUCTIONS:  
DOWNHAUL WEIGHT .....180 lbs  
ONE SHEAVE BLOCK.....375 lbs  
TWO SHEAVE BLOCK.....640 lbs  
THREE SHEAVE BLOCK.....870 lbs  
AUXILIARY SHEAVE.....100 lbs

DEDUCTIONS FOR STOWED EXTENDABLE JIB (lbs)

DEDUCTIONS FOR STOWED FIXED LENGTH JIB (lbs)

1-PART LINE	2-PART LINE	3-PART LINE	4-PART LINE	5-PART LINE	6-PART LINE	7-PART LINE	NOTICE
							* DO NOT DEADEND LINE BLOCK AGAINST BOOM TIP WHEN EXTENDING BOOM. * KEEP AT LEAST 3 WRAPS OF LOADLINE ON THE WHEEL DRUM AT ALL TIMES. * USE ONLY THE DIAMETER WIRE ROPE AS SPECIFIED BELOW WITH THE PROPER BREAKING STRENGTHS. * RATCHET-LOCK SYSTEM MUST BE ENGAGED BEFORE OPERATING CRANE. SEE OPERATOR SAFETY MANUAL. * RATED AT 100% OF SBC. ALL DIMENSIONS TO CENTERLINE. * RATED AT 100% OF SBC. ALL DIMENSIONS TO CENTERLINE.
MAX PULL: 9,600 lbs MAX PULL: 9,060 lbs	19,200 lbs 18,120 lbs	28,800 lbs 27,180 lbs	38,400 lbs 36,240 lbs	48,000 lbs 45,300 lbs	56,000 lbs 54,360 lbs	60,000 lbs 60,000 lbs	



Elliott Equipment Company  
3514 South 25th Street  
Omaha, NE 68105  
Phone: 402-592-4500  
Fax: 402-592-4553  
Email: sales@elliottequip.com

**Built for You.**  
www.elliottequip.com

**LOAD CHART - MAIN BOOM, MID-SPAN OUTRIGGERS**



**MODEL 3000 95-ft BOOM**

**MAIN BOOM LOAD RATINGS WITH OUTRIGGERS AT MID-SPAN POSITION**

**MAIN BOOM LOAD RATINGS**

LOAD RATINGS IN lbs WITH OUTRIGGERS AND STABILIZERS EXTENDED

LOAD RADIUS IN FEET	LOADED BOOM ANGLE	LOAD RATINGS IN lbs WITH OUTRIGGERS AND STABILIZERS EXTENDED										
		28-ft	LOADED BOOM ANGLE	A 43-ft	LOADED BOOM ANGLE	B 56-ft	LOADED BOOM ANGLE	C 69-ft	LOADED BOOM ANGLE	D 82-ft	LOADED BOOM ANGLE	E 95-ft
5	79.5	60,000										
8	72.6	44,000	79.5	32,700								
10	68	37,000	76.6	31,500								
12	63.2	32,000	74	27,400	78.4	26,800						
14	58.1	28,100	71	25,400	76.3	24,900	79.6	22,200				
16	52.7	21,400	68	21,400	74	21,400	78	21,400				
20	40.2	13,700	61.5	13,700	69.2	13,700	74	13,700	77.3	13,700	79.1	10,700
25	16.3	9,000	53.5	9,000	63.7	9,000	69.5	8,950	73.5	8,950	76.4	10,000
30			43.9	6,300	57.4	6,300	65	6,300	69.5	6,300	73.1	7,250
35			31.8	4,550	50.7	4,550	60	4,550	65.4	4,550	69.7	5,500
40			7.1	3,000	43.1	3,350	54.5	3,550	61.2	3,350	65.8	3,200
45					34.1	2,500	49	2,500	57	2,500	62.2	2,400
50					22	1,850	43	1,850	52.4	1,800	58.6	2,000
55							35.5	1,300	47.5	1,300	54.9	1,600
60							27	900	42.3	850	50.9	1,250
65							12.3	500	36.5	500	46.7	950
70											42.1	750
DEDUCTIONS FOR STOWED JIB (lb)		900		600		450		350		300		250
		600		400		300		250		200		200

**JIB LOAD RATINGS**

LOAD RATINGS IN lbs WITH OUTRIGGERS AND STABILIZERS EXTENDED

LOAD RADIUS IN FEET	LOADED BOOM ANGLE	LOAD RATINGS IN lbs WITH OUTRIGGERS AND STABILIZERS EXTENDED				
		24-ft FIXED LENGTH JIB		24-41 ft EXTENDABLE JIB		
		24-ft JIB	LOADED BOOM ANGLE	24-ft JIB RETRACTED	LOADED BOOM ANGLE	41-ft JIB EXTENDED
30	74.5	5,450	74.5	5,200	76.5	3,200
35	72	4,000	72	3,600	74.5	3,050
40	69.5	2,800	69.5	2,400	72	2,850
45	67	1,950	67	1,600	70	2,650
50	64.5	1,300	64.5	900	67.5	2,150
55	61.5	750			65.5	1,300

ELLIOTT EQUIPMENT CO. SUPPLIED  
 LOADLINE EQUIPMENT DEDUCTIONS:  
 DOWNHAUL WEIGHT .....180 lbs  
 ONE SHEAVE BLOCK.....375 lbs  
 TWO SHEAVE BLOCK.....640 lbs  
 THREE SHEAVE BLOCK.....870 lbs  
 AUXILIARY SHEAVE.....100 lbs

DEDUCTIONS FOR STOWED EXTENDABLE JIB (lbs)

DEDUCTIONS FOR STOWED FIXED LENGTH JIB (lbs)

**1-PART LINE**



**2-PART LINE**



**3-PART LINE**



**4-PART LINE**



**5-PART LINE**



**6-PART LINE**



**7-PART LINE**



**NOTICE**

- DO NOT DEADHEAD LINE BLOCK AGAINST BOOM TIP WHEN EXTENDING BOOM.
- KEEP AT LEAST 5 WRAPS OF LOADLINE ON THE WINCH DRUM AT ALL TIMES.
- USE ONLY 9/16" DIAMETER WIRE ROPE, AS SPECIFIED BELOW, WITH THE PROPER BREAKING STRENGTHS LISTED.
- ANTI-TWO-BLOCK SYSTEM MUST BE IN GOOD OPERATING CONDITION BEFORE OPERATING CRANE. SEE OPERATION & SAFETY MANUAL.

MAX PULL: 9,600 lbs

19,200 lbs

28,800 lbs

38,400 lbs

48,000 lbs

56,000 lbs

60,000 lbs

9/16" - 6 x 37 IWRC (3.5:1 S.F.)  
 33,600-lbs. BREAKING STRENGTH  
 9/16" - SPIN RESISTANT (6:1 S.F.)  
 45,300-lbs. BREAKING STRENGTH

MAX PULL: 9,060 lbs

18,120 lbs

27,180 lbs

36,240 lbs

45,300 lbs

54,360 lbs

60,000 lbs

CRANE MEETS ASME B30.5 REQUIREMENTS AT TIME OF MANUFACTURE

DO NOT PAINT OVER ANY LABELS

1113160 111308



Elliott Equipment Company  
 3514 South 25th Street  
 Omaha, NE 68105

Phone: 402-592-4500  
 Fax: 402-592-4553  
 Email: sales@elliottequip.com

**Built for You.**  
 www.elliottequip.com

**LOAD CHART - MAIN BOOM, RETRACTED OUTRIGGERS**



**MODEL 3000 95-ft BOOM**

**MAIN BOOM LOAD RATINGS WITH OUTRIGGERS AT FULL HORIZONTAL RETRACTED POSITION**

**MAIN BOOM LOAD RATINGS**

LOAD RATINGS IN lbs WITH OUTRIGGERS AND STABILIZERS EXTENDED

LOAD RADIUS IN FEET	LOADED BOOM ANGLE	28-ft	LOADED BOOM ANGLE	A 43-ft	LOADED BOOM ANGLE	B 56-ft	LOADED BOOM ANGLE	C 69-ft	LOADED BOOM ANGLE	D 82-ft	LOADED BOOM ANGLE	E 95-ft
5	79.5	60,000										
8	72.5	22,000	78.9	22,000								
10	67.5	14,900	76.1	14,900								
12	62.8	10,800	73.5	10,800	77.5	10,800						
14	58.9	8,200	70.7	8,200	75.6	8,200	78.7	8,200				
16	53.7	6,500	67.7	6,500	73.5	6,500	76.9	6,500	79.5	6,500		
20	41.6	4,400	61.5	4,400	68.9	4,400	73.5	4,400	76.3	4,400	78.3	4,400
25	16.5	2,550	53.1	2,550	63.1	2,550	68.7	2,550	72.5	2,550	74.9	2,550
30			43.6	1,450	56.8	1,450	63.9	1,450	68.5	1,450	71.6	1,450
35			31.6	700	50.1	700	59.1	700	64.6	700	68.5	700
DEDUCTIONS FOR STOWED JIB (lb)		900		600		450		350		300		250
		600		400		300		250		200		200

ELLIOTT EQUIPMENT CO. SUPPLIED  
 LOADLINE EQUIPMENT DEDUCTIONS:  
 DOWNHAUL WEIGHT .....180 lbs  
 ONE SHEAVE BLOCK.....375 lbs  
 TWO SHEAVE BLOCK.....640 lbs  
 THREE SHEAVE BLOCK.....870 lbs  
 AUXILIARY SHEAVE.....100 lbs

DEDUCTIONS FOR STOWED EXTENDABLE JIB (lbs)

DEDUCTIONS FOR STOWED FIXED LENGTH JIB (lbs)

1-PART LINE	2-PART LINE	3-PART LINE	4-PART LINE	5-PART LINE	6-PART LINE	7-PART LINE
MAX PULL: 9,600 lbs	19,200 lbs	28,800 lbs	38,400 lbs	48,000 lbs	56,000 lbs	60,000 lbs
MAX PULL: 9,060 lbs	18,120 lbs	27,180 lbs	36,240 lbs	45,300 lbs	54,360 lbs	60,000 lbs

**NOTICE**

- DO NOT DEADHEAD LINE BLOCK AGAINST BOOM TIP WHEN EXTENDING BOOM.
- KEEP AT LEAST 5 WRAPS OF LOADLINE ON THE WINCH DRUM AT ALL TIMES.
- USE ONLY 9/16" DIAMETER WIRE ROPE, AS SPECIFIED BELOW, WITH THE PROPER BREAKING STRENGTHS LISTED.
- ANTI-TWO-BLOCK SYSTEM MUST BE IN GOOD OPERATING CONDITION BEFORE OPERATING CRANE. SEE OPERATION & SAFETY MANUAL.

9/16" - 6 x 37 IWRC (3.5:1 S.F.)  
 33,600-lbs, BREAKING STRENGTH  
 9/16" - SPIN RESISTANT (5:1 S.F.)  
 45,300-lbs, BREAKING STRENGTH

CRANE MEETS ASME B30.5 REQUIREMENTS AT TIME OF MANUFACTURE

DO NOT PAINT OVER ANY LABELS

1113160 111308



Elliott Equipment Company  
 3514 South 25th Street  
 Omaha, NE 68105

Phone: 402-592-4500  
 Fax: 402-592-4553  
 Email: sales@elliottequip.com

**Built for You.**  
 www.elliottequip.com

**RANGE CHART - MAIN BOOM + JIB, FULL-SPAN OUTRIGGERS**



**MODEL 3000 95-ft BOOM**

**RANGE DIAGRAM WITH FULL SPAN OUTRIGGERS**

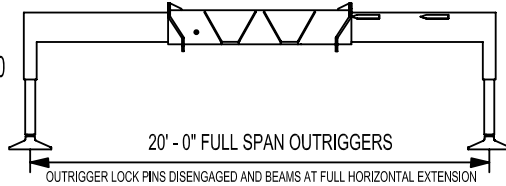
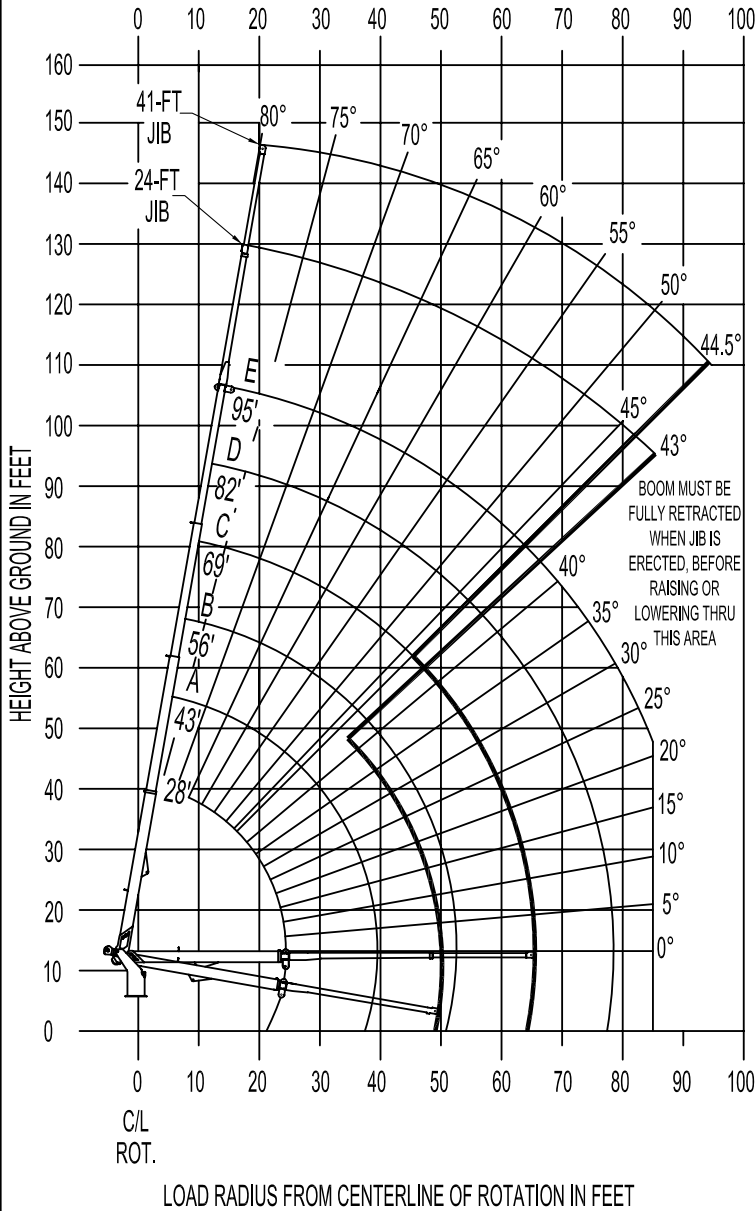

**NOTE:**

1. Operate jib by radius when main boom is full extended. Increase boom angle if necessary to maintain load radius.
2. When boom is retracted, operate jib by boom angles. Do not exceed any rated jib capacities at reduced boom lengths.
3. Capacities do not exceed 85% stability.
4. Load ratings above bold line are structurally limited.
5. Personnel handling is allowed only with full span outriggers.
6. Boom load ratings are based on loaded boom radius. Loaded boom angles are given as reference only.

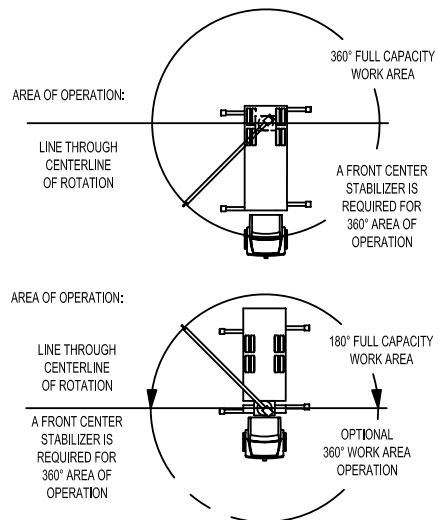

DO NOT PAINT OVER ANY LABELS 1113160 111308



Elliott Equipment Company  
3514 South 25th Street  
Omaha, NE 68105  
Phone: 402-592-4500  
Fax: 402-592-4553  
Email: sales@elliottequip.com

**Built for You.**  
www.elliottequip.com

**RANGE CHART - MAIN BOOM + JIB, MID-SPAN OUTRIGGERS**



**MODEL 3000 95-ft BOOM**

**RANGE DIAGRAM WITH OUTRIGGERS AT MID-SPAN POSITION**

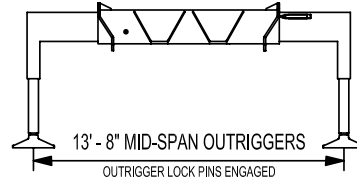
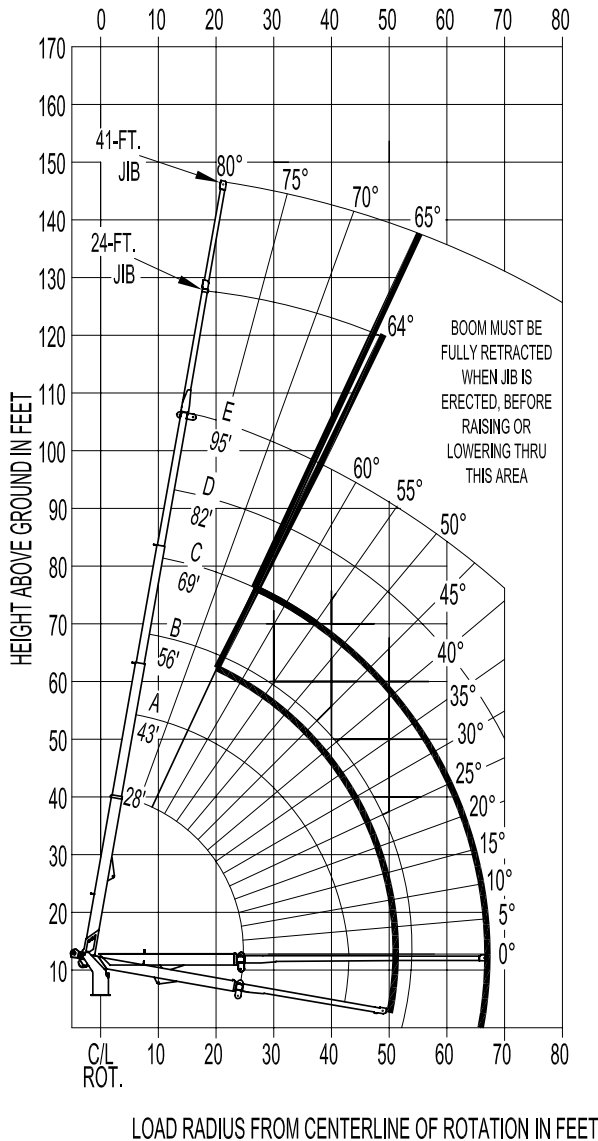

**NOTE:**

1. Operate jib by radius when main boom is full extended. Increase boom angle if necessary to maintain load radius.
2. When boom is retracted, operate jib by boom angles. Do not exceed any rated jib capacities at reduced boom lengths.
3. Capacities do not exceed stability based on ISO 4305-1991.
4. Load ratings above bold line are structurally limited.
5. Personnel handling is allowed only with full span outriggers.
6. Boom load ratings are based on loaded boom radius. Loaded boom angles are given as reference only.

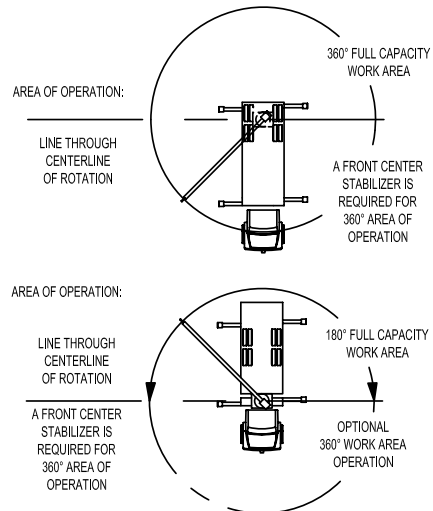

DO NOT PAINT OVER ANY LABELS 1113160 111308

**RANGE CHART - MAIN BOOM, RETRACTED OUTRIGGERS**



**MODEL 3000**

**95-ft BOOM**

**RANGE DIAGRAM WITH OUTRIGGERS  
AT FULL HORIZONTAL RETRACTED POSITION**

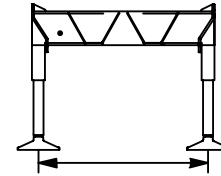
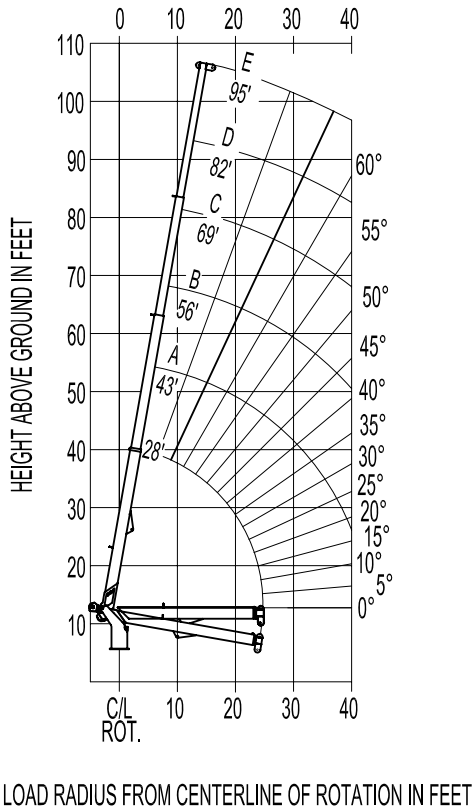

7' - 5" NO-SPAN OUTRIGGERS

**NOTE:**

1. Capacities do not exceed stability based on ISO 4305-1991.
2. Load ratings above bold line are structurally limited.
3. Personnel handling is allowed only with full span outriggers.
4. Boom load ratings are based on loaded boom radius.  
Loaded boom angles are given as reference only.

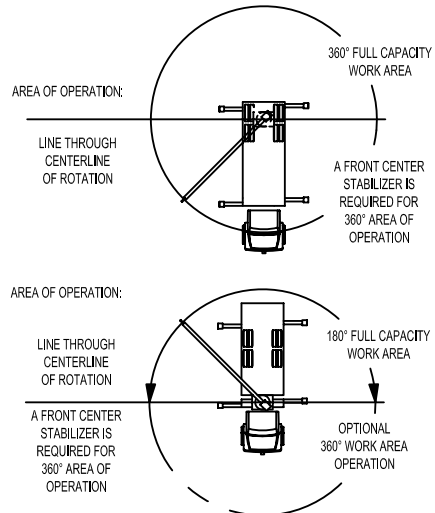

DO NOT PAINT OVER ANY LABELS

1113160

111308

## TRUCK CHASSIS SPECIFICATIONS

	3095R BoomTruck
Wheelbase (WB)	256" / 650 cm
Cab to Tandem (CT)	192" / 488 cm
Cab to End of Frame (EOF)	286" / 726 cm
Frame Section Modulus	30.0 in3-110,000 psi
Front Axle Gross Weight Rating	20,000 lb / 9071 kg
Rear Axle Gross Weight Rating	40,000 lb / 18 144 kg
Integral Front Frame Rails	Required for Front Stabilizer

Chassis data is minimum general requirements-not for engineering.  
 Actual dimensions and truck data will depend on truck selection and axle configuration.  
 \*Minimum chassis weight is required to meet 85% stability requirements.

## OPTIONS



### Radio Remote Control

Interference protected radio remotes let you get closer to your work and have full control over your machine. Includes battery charging feature and optional LMI screen.

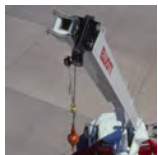

### Pin-On Jib Attachments

One piece & two piece telescoping or fixed jibs that stow on the side of the boom for easy placement while on the worksite.



### Custom Paint

Choose from a wide list of high quality paint applications including Elliott's standard white or red paint, metallic paints, or multiple colors.



### Digger / Auger Attachment

Dig faster and deeper with Elliott's auger attachment, offering 41' of digging range and a hydraulically powered auger that stows on the boom.



### Tool Boxes

Optional tool boxes and bed storage can accommodate any storage need for tools, work materials and more.



### Hook Block for Multi-Part Line

Elliott can install a 2-3 part hook block or a 4 part-hook block to improve lifting capabilities. The block can be stored at the rear of the bed.

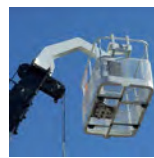

### Gravity Levelled Basket

Elliott's pin-on work platform pins onto the boom for easy installation and removal. Gravity leveling and mechanical rotation makes it a great accessory for any worksite.

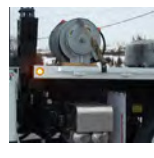

### Body Mounted Hose Reels and Circuits

Let us work with you to customize your tool compatibility by adding hose reels or hydraulic circuits to the crane bed.

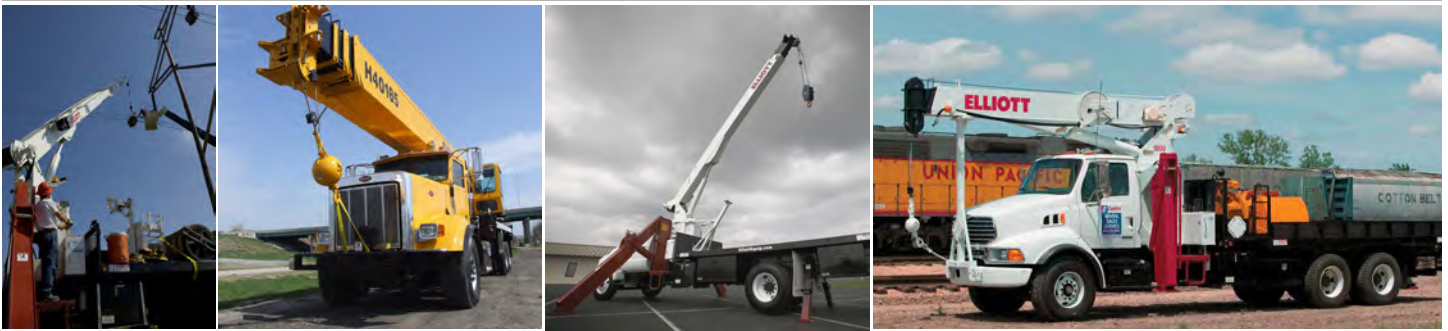

### 30105F SIDE VIEW DIAGRAM

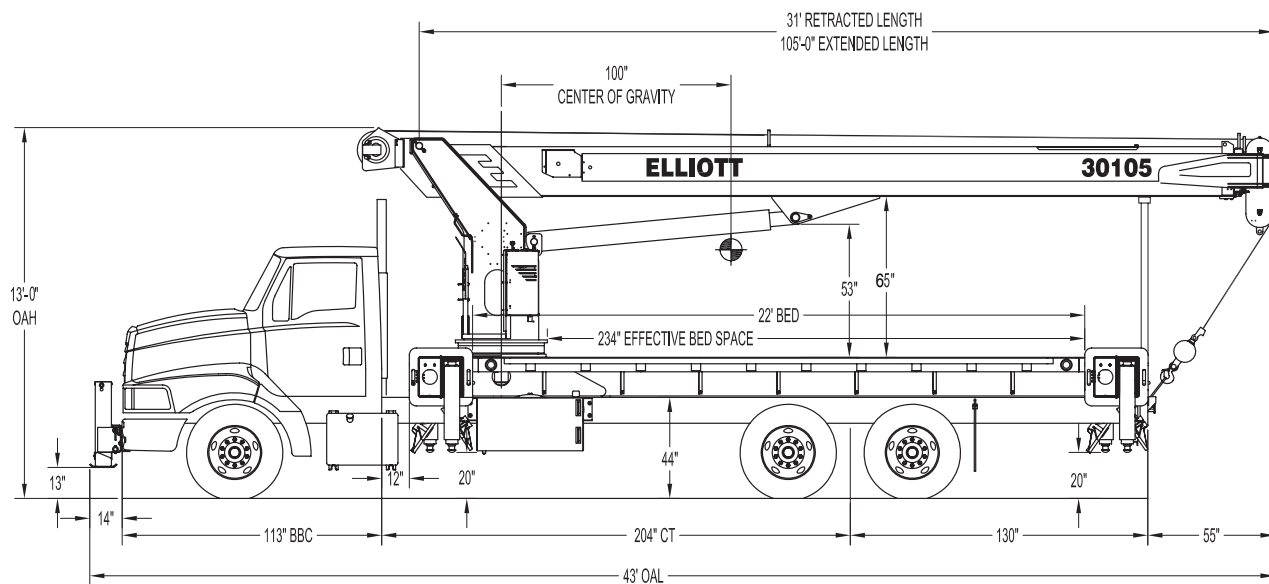

- |                                  |                                     |                                 |                  |
|----------------------------------|-------------------------------------|---------------------------------|------------------|
| • <b>Maximum Vertical Reach</b>  | 162' / 49,4 m                       | • <b>Powered Boom Sections</b>  | 4                |
| • <b>Working Area</b>            | 180 Degrees Standard (360 Optional) | • <b>Overall Height</b>         | 13' / 4 m        |
| • <b>Lifting Capacity</b>        | 60,000 lbs / 27 216 kg              | • <b>Operator Controls</b>      | Rotating Standup |
| • <b>Boom Length</b>             | 105' / 32 m                         | • <b>Outrigger Type Front</b>   | Out-Down         |
| • <b>Crane Weight (Standard)</b> | 28,160 lbs / 12 733 kg              | • <b>Outrigger Spread Front</b> | 20' / 6 m        |
| • <b>Jib Lengths</b>             | 26', 26-45' / 8-13,7 m              | • <b>Outrigger Type Rear</b>    | Out-Down         |
| • <b>Winch Bare Drum Pull</b>    | 12,800 lbs / 5806 kg                | • <b>Outrigger Spread Rear</b>  | 20' / 6 m        |

## TECHNICAL SPECIFICATIONS

**Crane Capacity:** 60,000 lbs at 5' load radius.

**Maximum Tip Height:** 117' tip height (162' with optional 45' jib)

**Control Console:** Rotating turret single operator standup control station equipped with four single axis control levers for the main crane controls. Operator station includes LMI display, bubble level gauge, engine start/stop switch, signal horn button, variable speed throttle switch, lifting capacity chart, range diagram chart, boom angle indicator, system pressure gauge, 12V DC power source, and cup holder. Independent ground level electric operated outrigger controls.

**Boom:** Four-section fully proportional, high strength steel plated rectangular tube sections. A maximum boom tip height of 117' mounted on a truck. The boom nose contains one floating upper sheave and three lower sheaves. Assembly includes heavy-duty cylinder fittings, pivot pins, and replaceable wear pads.

**Winch:** Mounted at the base of the boom for a long fleet angle and flat level spooling of cable. Winch is driven by a planetary reducer and powered by a hydraulic motor. Burst-of-speed winch provides increased line speed. The winch brake is spring applied, pressure release design. Supplied with 425' of 9/16" diameter rotation resistant wire rope with a single line pull of 9,060 pounds, and a downhaul ball with swivel hook for single part line.

**Load Moment Indicator System:** System senses hoist cylinder pressures, boom length and boom angle with hydraulic function lockout. The display console is equipped with a bar graph showing crane utilization, boom angle or boom length, a mode select controls for main boom and jib operation, and an anti-two block with an audio/visual warning and shut-off functions to limit hook-boom point contact.

Elliott Equipment Company reserves the right to change the specification of any unit at any time without prior notice. This brochure is only a statement of general specifications on the date of this publication. For more detailed info on specific Elliott trucks go to [www.elliottequip.com](http://www.elliottequip.com)

**Outriggers:** Two sets of out and down overframe outriggers with 20' span. Outriggers are configured for full span or mid span operation. Outriggers equipped with ball socket aluminum removable pads that stow on vertical outrigger legs.

**Frame:** Full length, all welded rigid 4-plate design sub-frame. Sub-frame allows for bolt-on addition of 22' bed wings, with top plate of subbase serving as a portion of the bed deck, to form a three-piece bed.

**Turret:** Reverse offset turret is one-piece weldment. Turret rotates on large diameter ball bearing.

**Rotation:** Hydraulic motor drives turret through double reduction planetary swing drive for 372-degree non-continuous rotation.

**Lift:** One double-acting long stroke cylinder provides smooth and stable boom elevation. Holding valve prevents boom from falling in event of hose failure.

**Boom Extension:** Incorporates a 2-stage hydraulic extension cylinder, attached to the largest boom section, with a proportional cable extension system driving the outermost sections.

**Hoses:** All high pressure hoses are wire braid reinforced with a minimum safety factor of 4 to 1.

**Cylinders:** All cylinders use microhoned cylinder tubing, chrome shafts, top grade packing and protective rod wipers. Cylinder-mounted holding valves provided on all load-holding cylinders.

**Hydraulic System:** Equipped with air-shift PTO, piston pump, SAE O-ring face seals on pressure lines, and a 10-micron return line filter. The control valve distributes all flow to hoist system, swing circuit, and other crane functions. System is closed center type.

**Oil Tank Capacity:** 120 gallon mounted to truck frame on roadside.

**Cab Equipment:** PTO switch with indicator lights installed in truck cab. U/L approved 5:BC dry chemical fire extinguisher installed in truck cab.

**Operators Manual & Video:** Two CD copies and one hard copy of operation, maintenance, safety and parts manual provided with each unit. Operational and safety video provided at delivery.

**Installation:** Unit installed on chassis, painted, system and tank filled with oil, tested, inspected, and ready to operate.

**Standard Paint:** Paint turret and boom white, outriggers red, and bed and boxes black. Top of bed painted with black nonskid surface.

**Bumper:** Bureau of Motor Carrier Safety rear bumper.

**Weight:** Approximately 28,160 lbs. with 22' steel-floor bed less truck.

**Truck Chassis Required:** Approx. 204" C.T. RBM 3,300,000 in-lb. per rail, 20,000 lb. front axle and 60,000 lb. GVWR required. Trucks must have front frame extension, 12V electrical system with high capacity alternator, cab clearance stop/tail/backup lights, and I.D. lamps. Recommended GVWR is minimum for BoomTruck with flatbed only. Contact factory when additional equipment is to be added.

**Options:**

45' or 26' Telescopic Jib  
Radio Remote Controls  
Gravity-Leveled Steel Basket  
Tool Box Configurations  
Front Jack for 360 Degree Crane Operation  
Much more...

**LOAD CHART - MAIN BOOM, FULL-SPAN OUTRIGGERS**

MAIN BOOM LOAD RATINGS WITH FULLY EXTENDED OUTRIGGERS														
MAIN BOOM LOAD RATINGS														
LOAD RATINGS IN lbs WITH OUTRIGGERS AND STABILIZERS EXTENDED														
LOAD RADIUS IN FEET	LOADED BOOM ANGLE	31-ft	LOADED BOOM ANGLE	A 46-ft	LOADED BOOM ANGLE	B 58-ft	LOADED BOOM ANGLE	C 70-ft	LOADED BOOM ANGLE	D 82-ft	LOADED BOOM ANGLE	E 94-ft	LOADED BOOM ANGLE	F 105-ft
5	80	60,000												
6	78	48,000												
8	74.2	38,600	79.2	32,000										
10	70.3	32,000	76.6	28,000										
12	66.2	27,500	74	26,000	77.4	25,300								
14	62	24,000	71.3	24,000	75.4	23,700	78	21,700						
16	57.6	20,800	68.6	22,500	73.3	22,200	76.3	20,400	78.3	17,500				
18	52.9	17,900	65.8	21,000	71.1	20,600	74.5	19,000	76.9	16,600	78.6	15,000		
20	47.8	15,600	62.9	19,000	69	19,100	72.8	17,800	75.4	15,500	77.3	13,600		
22	42.3	13,100	60	17,000	66.8	17,600	71	16,500	74	14,500	76.1	12,800	78	8,400
25	32.2	10,200	55.3	14,000	63.5	15,300	68.4	14,600	71.7	13,000	74.2	11,800	76.1	8,400
30			46.9	11,000	58.1	12,300	64.2	11,500	68.3	11,500	71.2	10,200	73.2	8,400
35			37.8	9,000	51.8	9,900	59.4	9,300	64.4	9,300	67.9	8,900	70.3	8,400
40			24.3	6,300	44.9	8,700	54.4	7,700	60.3	7,650	64.5	7,650	67.4	7,350
45					36.9	7,500	49	6,500	56.1	6,450	61	6,400	64.3	6,250
50					26.7	6,000	43.1	5,500	51.7	5,450	57.4	5,400	61.2	5,200
55							36.3	4,700	46.9	4,650	53.6	4,600	58	4,200
60							28.1	4,050	41.7	4,000	49.6	3,950	54.6	3,300
65							16.1	3,500	35.9	3,450	45.4	3,400	51.1	2,950
70									30	3,000	40.7	2,800	47.4	2,350
75									19.9	2,300	35.6	2,000	43.5	1,850
80											29.7	1,000	39.2	1,450
85											22.3	600	34.5	1,150
90													29.1	850
95													22.4	600
0	8,800	0	6,200	0	4,100									
DEDUCTIONS FOR STOWED JIB (lbs)	850		600		450		400		350		300		250	
	550		350		300		250		200		150		150	







  

JIB LOAD RATINGS						
LOAD RATINGS IN lbs WITH OUTRIGGERS AND STABILIZERS EXTENDED						
LOAD RADIUS IN FEET	LOADED BOOM ANGLE	26-ft FIXED LENGTH JIB		26-45 ft EXTENDABLE JIB		
		26-ft JIB	LOADED BOOM ANGLE	26-ft JIB RETRACTED	LOADED BOOM ANGLE	45-ft JIB EXTENDED
30	78.7	4,750	78.5	4,500		
35	76.5	4,350	76.3	4,100	77.4	2,600
40	74.3	3,950	74.1	3,700	75.4	2,500
45	72	3,450	71.7	3,200	74	2,400
50	69.5	3,050	69.3	2,800	72.2	2,250
55	67.1	2,650	66.8	2,400	70.3	2,050
60	64.6	2,350	64.3	2,100	68.3	1,900
65	62	2,050	61.7	1,800	66.2	1,750
70	59.4	1,850	59.1	1,600	64.2	1,600
75	56.7	1,650	56.4	1,400	62	1,400
80	53.9	1,450	53.6	1,200	59.7	1,200
85	51	1,250	50.6	1,000	57.3	1,100
90	47.8	1,050	47.5	800	55.1	1,000
95					52.6	850
100					49.6	500

ELLIOTT EQUIPMENT CO. SUPPLIED  
 LOADLINE EQUIPMENT DEDUCTIONS:  
 DOWNHAUL WEIGHT .....180 lbs  
 ONE SHEAVE BLOCK.....375 lbs  
 TWO SHEAVE BLOCK.....640 lbs  
 THREE SHEAVE BLOCK.....870 lbs  
 AUXILIARY SHEAVE.....100 lbs

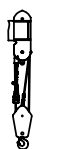
DEDUCTIONS FOR STOWED EXTENDABLE JIB (lbs)							DEDUCTIONS FOR STOWED FIXED LENGTH JIB (lbs)
1-PART LINE	2-PART LINE	3-PART LINE	4-PART LINE	5-PART LINE	6-PART LINE	7-PART LINE	NOTICE
							-DO NOT DEADEND LINE BLOCK AGAINST BOOM TIP WHEN EXTENDING BOOM -KEEP AT LEAST 3 WRAPS OF LOADLINE ON THE WINCH DRUM AT ALL TIMES. -USE ONLY 1/2" DIAMETER WIRE ROPE, AS SPECIFIED BELOW, WITH THE PROPER BREAKING STRENGTH LISTED. -INSTALL HOOK OR SYSTEM MUST BE IN GOOD OPERATING CONDITION BEFORE OPERATING CRANE. SEE OPERATION & SAFETY MANUAL. *SEE 11-17 PAGE 12/21 (S&U) FOR WIRE ROPE BREAKING STRENGTH **SEE OPERATING MANUAL (S&U) FOR WIRE ROPE BREAKING STRENGTH
MAX PULL: 9,600 lbs	19,200 lbs	28,800 lbs	38,400 lbs	48,000 lbs	57,600 lbs	60,000 lbs	
MAX PULL: 9,060 lbs	18,120 lbs	27,180 lbs	36,240 lbs	45,300 lbs	54,360 lbs	60,000 lbs	

**LOAD CHART - MAIN BOOM, MID-SPAN OUTRIGGERS**

**MAIN BOOM LOAD RATINGS WITH OUTRIGGERS AT MID-SPAN POSITION**

MAIN BOOM LOAD RATINGS													JIB LOAD RATINGS									
LOAD RATINGS IN lbs WITH OUTRIGGERS AND STABILIZERS EXTENDED													LOAD RATINGS IN lbs WITH OUTRIGGERS AND STABILIZERS EXTENDED									
LOAD RADIUS IN FEET	LOADED BOOM ANGLE	31-ft		46-ft		58-ft		70-ft		82-ft		94-ft		105-ft		LOAD RADIUS IN FEET	LOADED BOOM ANGLE	26-ft FIXED LENGTH JIB		26-45 ft EXTENDABLE JIB		
		LOADED BOOM ANGLE		LOADED BOOM ANGLE		LOADED BOOM ANGLE		LOADED BOOM ANGLE		LOADED BOOM ANGLE		LOADED BOOM ANGLE		LOADED BOOM ANGLE				26-ft JIB RETRACTED	LOADED BOOM ANGLE	45-ft JIB EXTENDED		
5	80	60,000														30	78.7	4,750	78.5	4,500		
6	78	48,000														35	76.5	4,350	76.3	4,100	77.4	2,600
8	74.2	38,600	79.2	32,000												40	74.3	3,950	74.1	3,600	75.4	2,500
10	70.3	32,000	76.6	28,000												45	72	2,950	71.7	2,700	74	2,400
12	66.2	27,500	74	26,000	77.4	25,300										50	69.5	2,200	69.3	1,900	72.2	2,250
14	62	21,300	71.3	24,000	75.4	23,700	78	21,700								55	67.1	1,550	66.8	1,300	70.3	2,000
16	57.6	19,500	68.6	20,000	73.3	20,000	76.3	20,400	78.3	17,500						60	64.6	1,050	64.3	800	68.3	1,450
18	52.9	15,800	65.8	15,800	71.1	16,600	74.5	16,300	76.9	16,600	78.6	15,000				65					66.2	1,050
20	48.9	12,200	62.9	13,000	69	13,300	72.8	13,400	75.4	13,900	77.3	13,600				70					64.2	750
22	42.3	9,500	60	10,500	66.8	11,000	71	11,000	74	11,200	76.1	11,000	78	8,400								
25	33.8	7,800	55.3	8,200	63.5	8,300	68.7	8,750	72	8,800	74.2	9,000	76.1	8,400								
30			46.9	5,900	58.1	6,100	64.2	6,150	68.3	6,200	71.2	6,400	73.2	6,500								
35			37.8	4,000	51.8	4,300	59.4	4,350	64.4	4,400	67.9	4,600	70.3	4,700								
40			24.3	2,800	44.9	3,100	54.4	3,150	60.3	3,200	64.5	3,300	67.4	3,400								
45					36.9	2,200	49	2,250	56.1	2,300	61	2,400	64.3	2,500								
50					26.7	1,450	43.1	1,550	51.7	1,600	57.4	1,700	61.2	1,800								
55							36.3	1,000	46.9	1,050	53.6	1,150	58	1,200								
60									41.7	650	49.6	700	54.6	750								
0	5,200	0	2,200	0	650																	
DEDUCTIONS FOR STOWED JIB (lbs)		850	600	450	400	350	300	250	200	150	150				DEDUCTIONS FOR STOWED EXTENDABLE JIB (lbs)							
		550	350	300	250	200	150	150							DEDUCTIONS FOR STOWED FIXED LENGTH JIB (lbs)							

ELLIOTT EQUIPMENT CO. SUPPLIED  
 LOADLINE EQUIPMENT DEDUCTIONS:  
 DOWNHAUL WEIGHT .....180 lbs  
 ONE SHEAVE BLOCK.....375 lbs  
 TWO SHEAVE BLOCK.....640 lbs  
 THREE SHEAVE BLOCK.....870 lbs  
 AUXILIARY SHEAVE.....100 lbs

1-PART LINE	2-PART LINE	3-PART LINE	4-PART LINE	5-PART LINE	6-PART LINE	7-PART LINE	NOTICE
							<ul style="list-style-type: none"> <li>- DO NOT DEADHEAD LINE BLOCK AGAINST BOOM TIP WHEN EXTENDING BOOM.</li> <li>- KEEP AT LEAST 5 WRAPS OF LOADLINE ON THE WINCH DRUM AT ALL TIMES.</li> <li>- USE ONLY 9/16" DIAMETER WIRE ROPE, AS SPECIFIED BELOW, WITH THE PROPER BREAKING STRENGTHS LISTED.</li> <li>- ANTI-TWO-BLOCK SYSTEM MUST BE IN GOOD OPERATING CONDITION BEFORE OPERATING CRANE. SEE OPERATION &amp; SAFETY MANUAL.</li> </ul>
MAX PULL: 9,600 lbs	19,200 lbs	28,800 lbs	38,400 lbs	48,000 lbs	57,600 lbs	60,000 lbs	9/16" - 6 x 37 IWRC (3.5:1 S.F.) 33,600-lbs. BREAKING STRENGTH
MAX PULL: 9,060 lbs	18,120 lbs	27,180 lbs	36,240 lbs	45,300 lbs	54,360 lbs	60,000 lbs	9/16" - SPIN RESISTANT (5:1 S.F.) 45,300-lbs. BREAKING STRENGTH

CRANE MEETS ASME B30.5 REQUIREMENTS AT TIME OF MANUFACTURE

DO NOT PAINT OVER ANY LABELS

1113150 061406

**RANGE CHART - MAIN BOOM + JIB, FULL-SPAN OUTRIGGERS**

**RANGE DIAGRAM WITH FULL SPAN OUTRIGGERS**

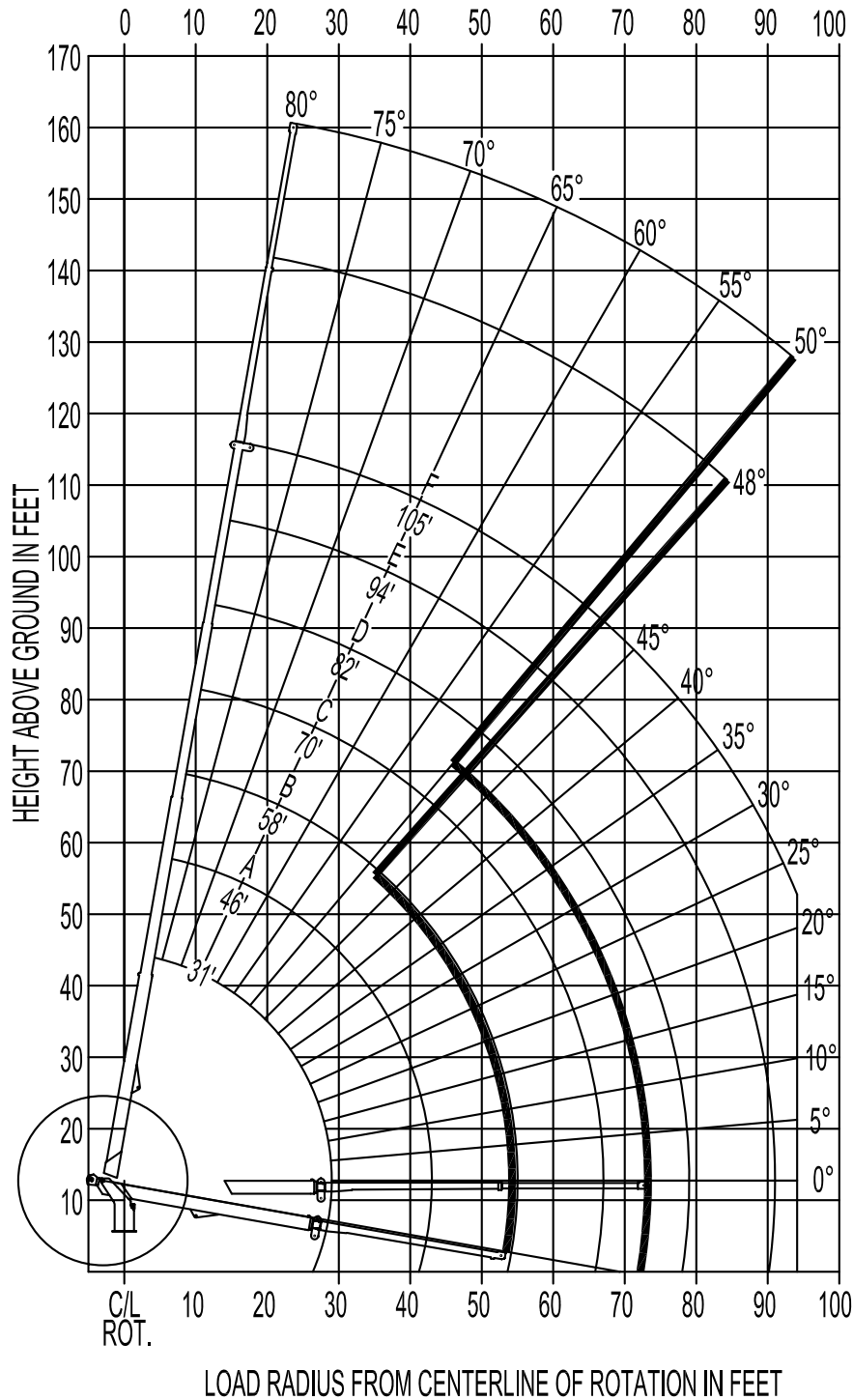

**RANGE CHART - MAIN BOOM + JIB, MID-SPAN OUTRIGGERS**

**RANGE DIAGRAM WITH OUTRIGGERS AT MID-SPAN POSITION**

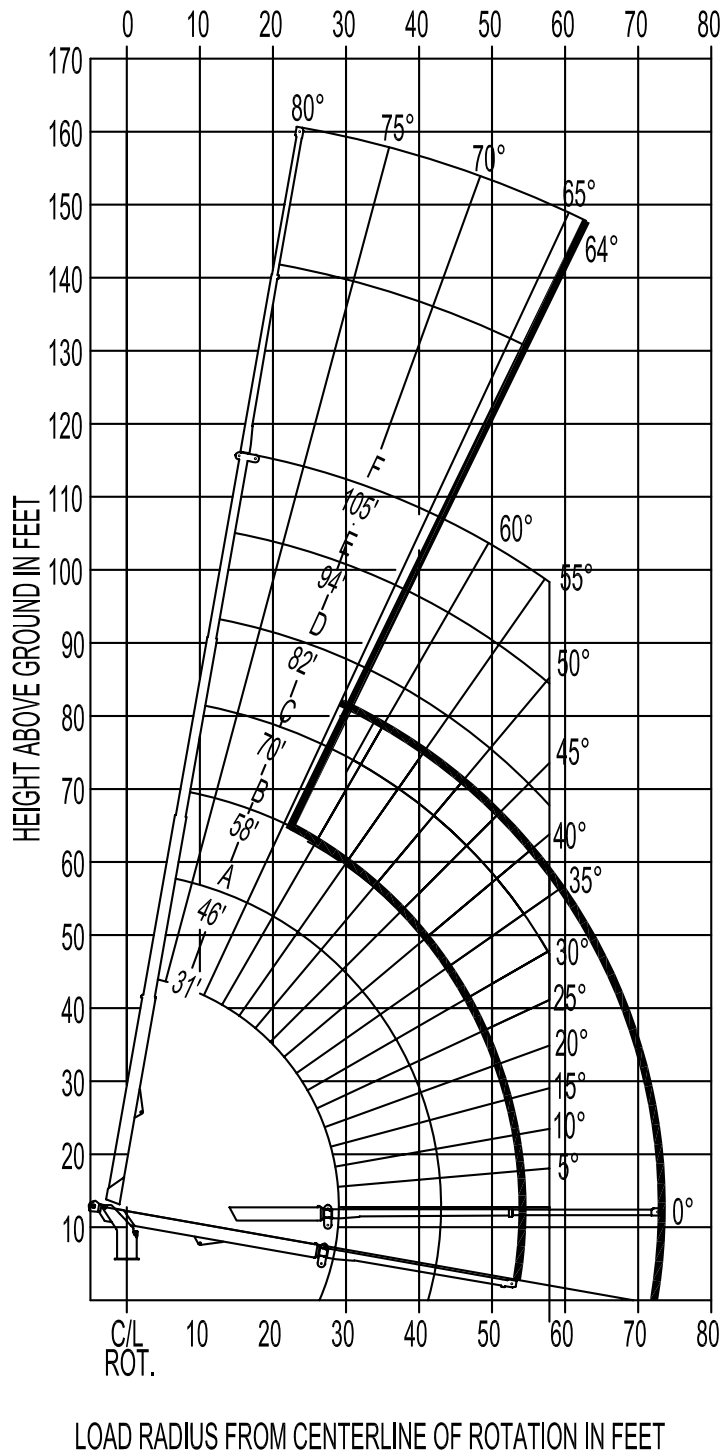

**TRUCK CHASSIS SPECIFICATIONS**

	30105F BoomTruck
Wheelbase (WB)	268" / 681 cm
Cab to Tandem (CT)	204" / 518 cm
Cab to End of Frame (EOF)	334" / 594 cm
Frame Section Modulus	30.0 in3-110,000 psi
Front Axle Gross Weight Rating	20,000 lb / 9,071 kg
Rear Axle Gross Weight Rating	40,000 lb / 18,143 kg
Integral Front Frame Rails	Required for Front Stabilizer

Chassis data is minimum general requirements-not for engineering.  
 Actual dimensions and truck data will depend on truck selection and axle configuration.  
 \*Minimum chassis weight is required to meet 85% stability requirements.

**OPTIONS**



**Radio Remote Control**

Interference protected radio remotes let you get closer to your work and have full control over your machine. Includes battery charging feature and optional LMI screen.

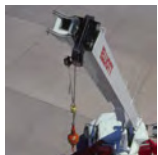

**Pin-On Jib Attachments**

One piece & two piece telescoping or fixed jibs that stow on the side of the boom for easy placement while on the worksite.



**Continuous Boom Rotation**

Add the convenience of 360 degree continuous rotation by adding a special boom rotation bearing for swinging without stops.



**Digger / Auger Attachment**

Dig faster and deeper with Elliott's auger attachment, offering 44' of digging range and a hydraulically powered auger that stows on the boom.



**Tool Boxes**

Optional tool boxes and bed storage can accommodate any storage need for tools, work materials and more.

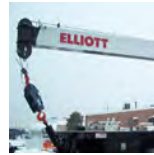

**Hook Block for Multi-Part Line**

Elliott can install a 2-3 part hook block or a 4 part-hook block to improve lifting capabilities. The block can be stored at the rear of the bed.



**Gravity Levelled Basket**

Elliott's pin-on work platform pins onto the boom for easy installation and removal. Gravity leveling and mechanical rotation makes it a great accessory for any worksite.

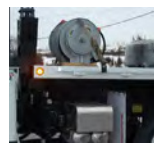

**Body Mounted Hose Reels and Circuits**

Let us work with you to customize your tool compatibility by adding hose reels or hydraulic circuits to the crane bed.

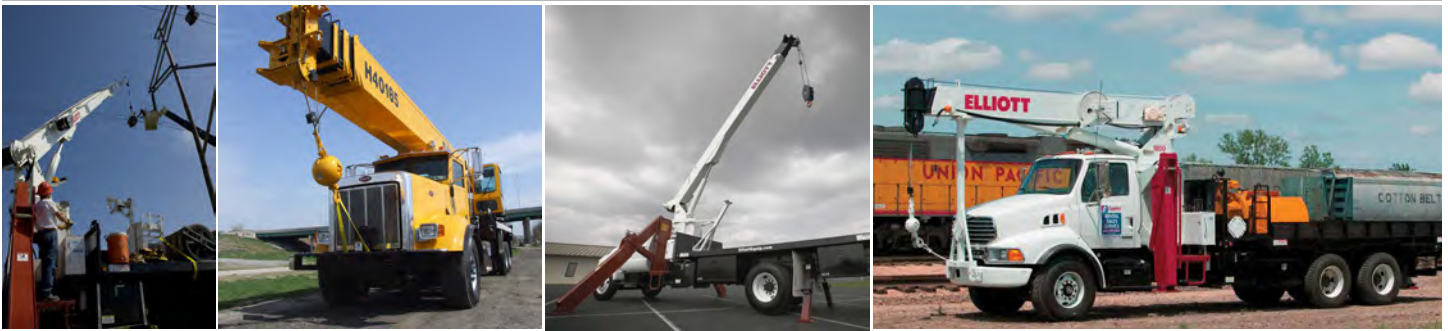

### 30105R SIDE VIEW DIAGRAM

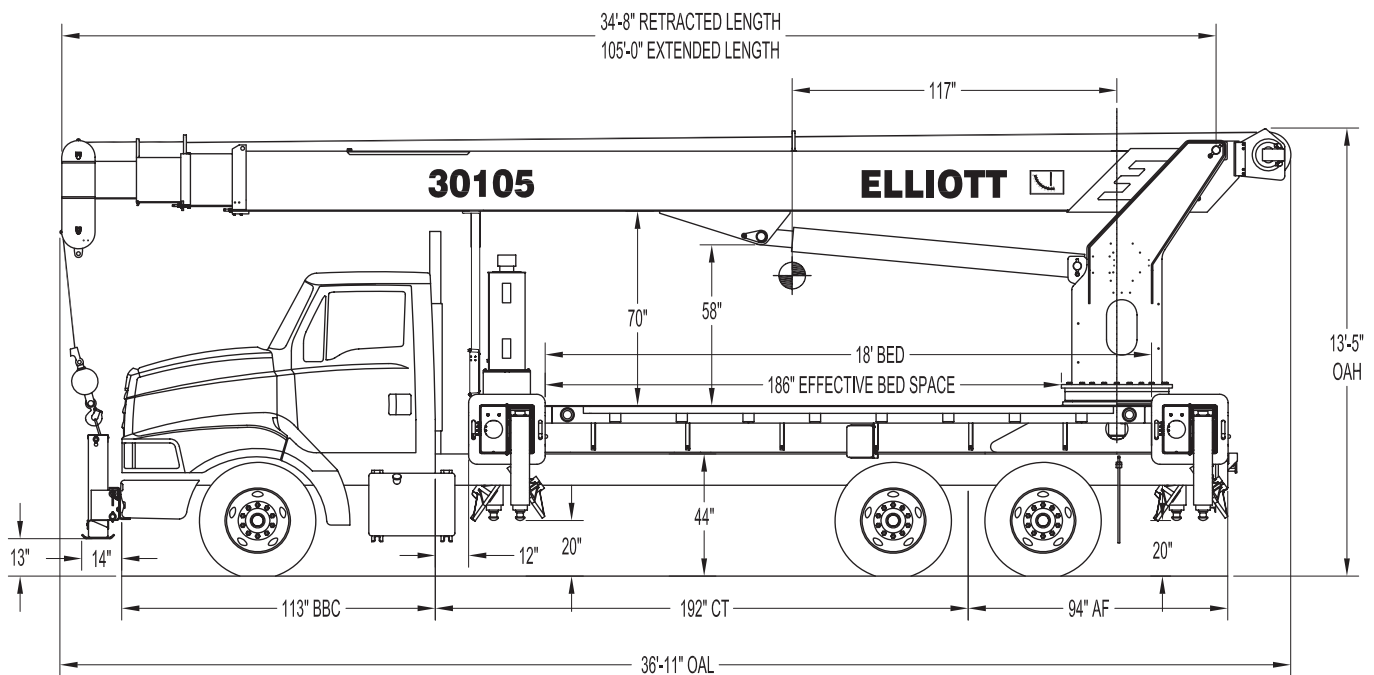

- |                                  |                           |                                 |                  |
|----------------------------------|---------------------------|---------------------------------|------------------|
| • <b>Maximum Vertical Reach</b>  | 162' / 49,4 m             | • <b>Powered Boom Sections</b>  | 4                |
| • <b>Working Area</b>            | 360 Degrees               | • <b>Overall Height</b>         | 13'5" / 4 m      |
| • <b>Lifting Capacity</b>        | 60,000 lbs / 27 216 kg    | • <b>Operator Controls</b>      | Rotating Standup |
| • <b>Boom Length</b>             | 105' / 32 m               | • <b>Outrigger Type Front</b>   | Out-Down         |
| • <b>Crane Weight (Standard)</b> | 28,160 lbs / 12 733 kg    | • <b>Outrigger Spread Front</b> | 20' / 6 m        |
| • <b>Jib Lengths</b>             | 26', 26-45' / 8, 8-13,7 m | • <b>Outrigger Type Rear</b>    | Out-Down         |
| • <b>Winch Bare Drum Pull</b>    | 12,800 lbs / 5806 kg      | • <b>Outrigger Spread Rear</b>  | 20' / 6 m        |

## TECHNICAL SPECIFICATIONS

**Crane Capacity:** 60,000 lbs at 5' load radius.

**Maximum Tip Height:** 117' height (162' with optional 45' jib)

**Control Console:** Rotating turret single operator standup control station equipped with four single axis control levers for the main crane controls. Operator station includes LMI display, bubble level gauge, engine start/stop switch, signal horn button, variable speed throttle switch, lifting capacity chart, range diagram chart, boom angle indicator, system pressure gauge, 12V DC power source, and cup holder. Independent ground level electric operated outrigger controls.

**Boom:** Four-section fully proportional, high strength steel plated rectangular tube sections. A maximum boom tip height of 117' mounted on a truck. The boom nose contains one floating upper sheave and three lower sheaves. Assembly includes heavy-duty cylinder fittings, pivot pins, and replaceable wear pads.

**Winch:** Mounted at the base of the boom for a long fleet angle and flat level spooling of cable. Winch is driven by a planetary reducer and powered by a hydraulic motor. Burst-of-speed winch provides increased line speed. The winch brake is spring applied, pressure release design. Supplied with 425' of 9/16" diameter rotation resistant wire rope with a single line pull of 9,060 pounds, and a downhaul ball with swivel hook for single part line.

**Load Moment Indicator System:** System senses hoist cylinder pressures, boom length and boom angle with hydraulic function lockout. The display console is equipped with a bar graph showing crane utilization, boom angle or boom length, a mode select controls for main boom and jib operation, and an anti-two block with an audio/visual warning and shut-off functions to limit hook-boom point contact.

Elliott Equipment Company reserves the right to change the specification of any unit at any time without prior notice. This brochure is only a statement of general specifications on the date of this publication. For more detailed info on specific Elliott trucks go to [www.elliottequip.com](http://www.elliottequip.com)

**Outriggers:** Two sets of out and down overframe outriggers with 20' span. Outriggers are configured for full span or mid span operation. Outriggers equipped with ball socket aluminum removable pads that stow on vertical outrigger legs. Single front bumper stabilizer.

**Frame:** Full length, all welded rigid 4-plate design sub-frame. Sub-frame allows for bolt-on addition of 18' bed wings, with top plate of subbase serving as a portion of the bed deck, to form a three-piece bed.

**Turret:** Reverse offset turret is one-piece weldment. Turret rotates on large diameter ball bearing.

**Rotation:** Hydraulic motor drives turret through double reduction planetary swing drive for 360 degree continuous rotation. Glide-swing available with seated control option only.

**Lift:** One double-acting long stroke cylinder provides smooth and stable boom elevation. Holding valve prevents boom from falling in event of hose failure.

**Boom Extension:** Incorporates a 2-stage hydraulic extension cylinder, attached to the largest boom section, with a proportional cable extension system driving the outermost sections.

**Hoses:** All high pressure hoses are wire braid reinforced with a minimum safety factor of 4 to 1.

**Cylinders:** All cylinders use microhoned cylinder tubing, chrome shafts, top grade packing and protective rod wipers. Cylinder-mounted holding valves provided on all load-holding cylinders.

**Hydraulic System:** Equipped with air-shift PTO, piston pump, SAE O-ring face seals on pressure lines, and a 10-micron return line filter. The control valve distributes all flow to hoist system, swing circuit, and other crane functions. System is closed center type.

**Oil Tank Capacity:** 143 gallon mounted on top of front outriggers.

**Cab Equipment:** PTO switch with indicator lights installed in truck cab. U/L approved 5:BC dry chemical fire extinguisher installed in truck cab.

**Operators Manual & Video:** Two CD copies and one hard copy of operation, maintenance, safety and parts manual provided with each unit. Operational and safety video provided at delivery.

**Installation:** Unit installed on chassis, painted, system and tank filled with oil, tested, inspected, and ready to operate.

**Standard Paint:** Paint turret and boom white, outriggers red, and bed and boxes black. Top of bed painted with black nonskid surface.

**Bumper:** Bureau of Motor Carrier Safety rear bumper.

**Weight:** Approximately 28,160 lbs. with 18' steel-floor bed less truck.

**Truck Chassis Required:** Approx. 192" C.T. RBM 3,300,000 in-lb. per rail, 20,000 lb. front axle and 60,000 lb. GVWR required. Trucks must have front frame extension, 12V electrical system with high capacity alternator, cab clearance stop/tail/backup lights, and I.D. lamps. Recommended GVWR is minimum for BoomTruck with flatbed only. Contact factory when additional equipment is to be added.

**Options:**

- 26' Fixed or 45' Telescopic Jib.
- Rotating Open-Seated Controls.
- Rotating Seated Controls with Cab.
- Radio Remote Controls.
- Gravity-Leveled Steel Basket.
- Tool Box Configurations.
- Multi-Part Line Block and Storage.
- Much More...

**LOAD CHART - MAIN BOOM, FULL-SPAN OUTRIGGERS**

MAIN BOOM LOAD RATINGS WITH FULLY EXTENDED OUTRIGGERS														
MAIN BOOM LOAD RATINGS														
LOAD RATINGS IN lbs WITH OUTRIGGERS AND STABILIZERS EXTENDED														
LOAD RADIUS IN FEET	LOADED BOOM ANGLE	31-ft	LOADED BOOM ANGLE	A 46-ft	LOADED BOOM ANGLE	B 58-ft	LOADED BOOM ANGLE	C 70-ft	LOADED BOOM ANGLE	D 82-ft	LOADED BOOM ANGLE	E 94-ft	LOADED BOOM ANGLE	F 105-ft
5	80	60,000												
6	78	48,000												
8	74.2	38,600	79.2	32,000										
10	70.3	32,000	76.6	28,000										
12	66.2	27,500	74	26,000	77.4	25,300								
14	62	24,000	71.3	24,000	75.4	23,700	78	21,700						
16	57.6	20,800	68.6	22,500	73.3	22,200	76.3	20,400	78.3	17,500				
18	52.9	17,900	65.8	21,000	71.1	20,600	74.5	19,000	76.9	16,600	78.6	15,000		
20	47.8	15,600	62.9	19,000	69	19,100	72.8	17,800	75.4	15,500	77.3	13,600		
22	42.3	13,100	60	17,000	66.8	17,600	71	16,500	74	14,500	76.1	12,800	78	8,400
25	32.2	10,200	55.3	14,000	63.5	15,300	68.4	14,600	71.7	13,000	74.2	11,800	76.1	8,400
30			46.9	11,000	58.1	12,300	64.2	11,500	68.3	11,500	71.2	10,200	73.2	8,400
35			37.8	9,000	51.8	9,900	59.4	9,300	64.4	9,300	67.9	8,900	70.3	8,400
40			24.3	6,300	44.9	8,700	54.4	7,700	60.3	7,650	64.5	7,650	67.4	7,350
45					36.9	7,500	49	6,500	56.1	6,450	61	6,400	64.3	6,250
50					26.7	6,000	43.1	5,500	51.7	5,450	57.4	5,400	61.2	5,200
55							36.3	4,700	46.9	4,650	53.6	4,600	58	4,200
60							28.1	4,050	41.7	4,000	49.6	3,950	54.6	3,300
65							16.1	3,500	35.9	3,450	45.4	3,400	51.1	2,950
70									30	3,000	40.7	2,800	47.4	2,350
75									19.9	2,300	35.6	2,000	43.5	1,850
80											29.7	1,000	39.2	1,450
85											22.3	600	34.5	1,150
90													29.1	850
95													22.4	600
0		8,800	0	6,200	0	4,100								
DEDUCTIONS FOR STOWED JIB (lbs)	850		600		450		400		350		300		250	
	550		350		300		250		200		150		150	









  

JIB LOAD RATINGS						
LOAD RATINGS IN lbs WITH OUTRIGGERS AND STABILIZERS EXTENDED						
LOAD RADIUS IN FEET	LOADED BOOM ANGLE	26-ft FIXED LENGTH JIB		26-45 ft EXTENDABLE JIB		
		26-ft JIB	LOADED BOOM ANGLE	26-ft JIB RETRACTED	LOADED BOOM ANGLE	45-ft JIB EXTENDED
30	78.7	4,750	78.5	4,500		
35	76.5	4,350	76.3	4,100	77.4	2,600
40	74.3	3,950	74.1	3,700	75.4	2,500
45	72	3,450	71.7	3,200	74	2,400
50	69.5	3,050	69.3	2,800	72.2	2,250
55	67.1	2,650	66.8	2,400	70.3	2,050
60	64.6	2,350	64.3	2,100	68.3	1,900
65	62	2,050	61.7	1,800	66.2	1,750
70	59.4	1,850	59.1	1,600	64.2	1,600
75	56.7	1,650	56.4	1,400	62	1,400
80	53.9	1,450	53.6	1,200	59.7	1,200
85	51	1,250	50.6	1,000	57.3	1,100
90	47.8	1,050	47.5	800	55.1	1,000
95					52.6	850
100					49.6	500

ELLIOTT EQUIPMENT CO. SUPPLIED  
 LOADLINE EQUIPMENT DEDUCTIONS:  
 DOWNHAUL WEIGHT .....180 lbs  
 ONE SHEAVE BLOCK.....375 lbs  
 TWO SHEAVE BLOCK.....640 lbs  
 THREE SHEAVE BLOCK.....870 lbs  
 AUXILIARY SHEAVE.....100 lbs

DEDUCTIONS FOR STOWED EXTENDABLE JIB (lbs)							DEDUCTIONS FOR STOWED FIXED LENGTH JIB (lbs)							
1-PART LINE	2-PART LINE	3-PART LINE	4-PART LINE	5-PART LINE	6-PART LINE	7-PART LINE	8-PART LINE	9-PART LINE	10-PART LINE	11-PART LINE	12-PART LINE	13-PART LINE	14-PART LINE	15-PART LINE
														
MAX PULL: 9,600 lbs	19,200 lbs	28,800 lbs	38,400 lbs	48,000 lbs	57,600 lbs	60,000 lbs								
MAX PULL: 9,060 lbs	18,120 lbs	27,180 lbs	36,240 lbs	45,300 lbs	54,360 lbs	60,000 lbs								

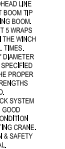
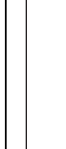
CRANE MEETS ASME B30.1 REQUIREMENTS AT TIME OF MANUFACTURE

NOTICE  
 -DO NOT DEADEND LINE BLOCK AGAINST BOOM TIP WHEN EXTENDING BOOM  
 -KEEP AT LEAST 3 WRAPS OF LOADLINE ON THE WINCH DRUM AT ALL TIMES.  
 -USE ONLY 1/2" DIAMETER WIRE ROPE, AS SPECIFIED BELOW, WITH THE PROPER BREAKING STRENGTH LISTED.  
 -INSTALL HOOK OR SYSTEM MUST BE IN GOOD OPERATING CONDITION BEFORE OPERATING CRANE. SEE OPERATION & SAFETY MANUAL.  
100'-10 1/2" MAXIMUM LIFT CAPACITY  
 100'-10 1/2" MAXIMUM BREAKING STRENGTH  
 100'-10 1/2" MAXIMUM LIFT CAPACITY  
 100'-10 1/2" MAXIMUM BREAKING STRENGTH

DO NOT PULL OVER ANY LABELS 111310 06/06



Elliott Equipment Company  
 3514 South 25th Street  
 Omaha, NE 68105  
 Phone: 402-592-4500  
 Fax: 402-592-4553  
 Email: sales@elliottequip.com

**Built for You.**  
 www.elliottequip.com

**LOAD CHART - MAIN BOOM, MID-SPAN OUTRIGGERS**

**MAIN BOOM LOAD RATINGS WITH OUTRIGGERS AT MID-SPAN POSITION**

MAIN BOOM LOAD RATINGS													JIB LOAD RATINGS									
LOAD RATINGS IN lbs WITH OUTRIGGERS AND STABILIZERS EXTENDED													LOAD RATINGS IN lbs WITH OUTRIGGERS AND STABILIZERS EXTENDED									
LOAD RADIUS IN FEET	LOADED BOOM ANGLE	31-ft		46-ft		58-ft		70-ft		82-ft		94-ft		105-ft		LOAD RADIUS IN FEET	LOADED BOOM ANGLE	26-ft FIXED LENGTH JIB		26-45 ft EXTENDABLE JIB		
		LOADED BOOM ANGLE		LOADED BOOM ANGLE		LOADED BOOM ANGLE		LOADED BOOM ANGLE		LOADED BOOM ANGLE		LOADED BOOM ANGLE		LOADED BOOM ANGLE				26-ft JIB RETRACTED	LOADED BOOM ANGLE	45-ft JIB EXTENDED		
5	80	60,000														30	78.7	4,750	78.5	4,500		
6	78	48,000														35	76.5	4,350	76.3	4,100	77.4	2,600
8	74.2	38,600	79.2	32,000											40	74.3	3,950	74.1	3,600	75.4	2,500	
10	70.3	32,000	76.6	28,000											45	72	2,950	71.7	2,700	74	2,400	
12	66.2	27,500	74	26,000	77.4	25,300									50	69.5	2,200	69.3	1,900	72.2	2,250	
14	62	21,300	71.3	24,000	75.4	23,700	78	21,700							55	67.1	1,550	66.8	1,300	70.3	2,000	
16	57.6	19,500	68.6	20,000	73.3	20,000	76.3	20,400	78.3	17,500					60	64.6	1,050	64.3	800	68.3	1,450	
18	52.9	15,800	65.8	15,800	71.1	16,600	74.5	16,300	76.9	16,600	78.6	15,000			65					66.2	1,050	
20	48.9	12,200	62.9	13,000	69	13,300	72.8	13,400	75.4	13,900	77.3	13,600			70					64.2	750	
22	42.3	9,500	60	10,500	66.8	11,000	71	11,000	74	11,200	76.1	11,000	78	8,400								
25	33.8	7,800	55.3	8,200	63.5	8,300	68.7	8,750	72	8,800	74.2	9,000	76.1	8,400								
30			46.9	5,900	58.1	6,100	64.2	6,150	68.3	6,200	71.2	6,400	73.2	6,500								
35			37.8	4,000	51.8	4,300	59.4	4,350	64.4	4,400	67.9	4,600	70.3	4,700								
40			24.3	2,800	44.9	3,100	54.4	3,150	60.3	3,200	64.5	3,300	67.4	3,400								
45					36.9	2,200	49	2,250	56.1	2,300	61	2,400	64.3	2,500								
50					26.7	1,450	43.1	1,550	51.7	1,600	57.4	1,700	61.2	1,800								
55							36.3	1,000	46.9	1,050	53.6	1,150	58	1,200								
60									41.7	650	49.6	700	54.6	750								
0	5,200	0	2,200	0	650																	
DEDUCTIONS FOR STOWED JIB (lbs)	850		600		450		400		350		300		250									
	550		350		300		250		200		150		150									

ELLIOTT EQUIPMENT CO. SUPPLIED  
 LOADLINE EQUIPMENT DEDUCTIONS:  
 DOWNHAUL WEIGHT .....180 lbs  
 ONE SHEAVE BLOCK.....375 lbs  
 TWO SHEAVE BLOCK.....640 lbs  
 THREE SHEAVE BLOCK.....870 lbs  
 AUXILIARY SHEAVE.....100 lbs

DEDUCTIONS FOR STOWED EXTENDABLE JIB (lbs)  
 DEDUCTIONS FOR STOWED FIXED LENGTH JIB (lbs)

1-PART LINE	2-PART LINE	3-PART LINE	4-PART LINE	5-PART LINE	6-PART LINE	7-PART LINE	NOTICE
							<ul style="list-style-type: none"> <li>- DO NOT DEADHEAD LINE BLOCK AGAINST BOOM TIP WHEN EXTENDING BOOM.</li> <li>- KEEP AT LEAST 5 WRAPS OF LOADLINE ON THE WINCH DRUM AT ALL TIMES.</li> <li>- USE ONLY 9/16" DIAMETER WIRE ROPE, AS SPECIFIED BELOW, WITH THE PROPER BREAKING STRENGTHS LISTED.</li> <li>- ANTI-TWO-BLOCK SYSTEM MUST BE IN GOOD OPERATING CONDITION BEFORE OPERATING CRANE. SEE OPERATION &amp; SAFETY MANUAL.</li> </ul>
MAX PULL: 9,600 lbs	19,200 lbs	28,800 lbs	38,400 lbs	48,000 lbs	57,600 lbs	60,000 lbs	9/16" - 6 x 37 IWRC (3.5:1 S.F.) 33,600-lbs. BREAKING STRENGTH
MAX PULL: 9,060 lbs	18,120 lbs	27,180 lbs	36,240 lbs	45,300 lbs	54,360 lbs	60,000 lbs	9/16" - SPIN RESISTANT (5:1 S.F.) 45,300-lbs. BREAKING STRENGTH

CRANE MEETS ASME B30.5 REQUIREMENTS AT TIME OF MANUFACTURE

DO NOT PAINT OVER ANY LABELS

1113150 061406

**RANGE CHART - MAIN BOOM + JIB, FULL-SPAN OUTRIGGERS**

**RANGE DIAGRAM WITH FULL SPAN OUTRIGGERS**

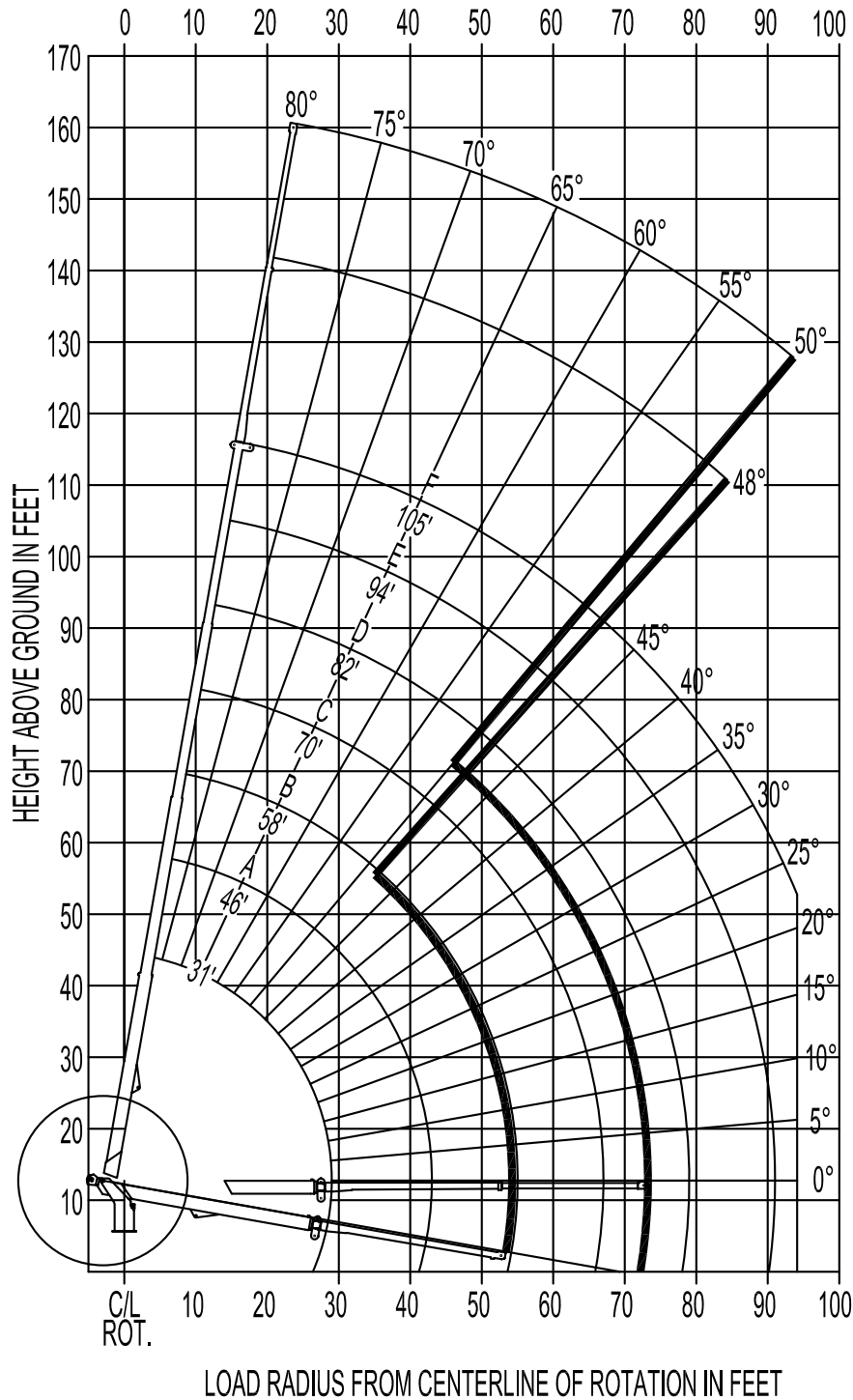

**RANGE CHART - MAIN BOOM + JIB, MID-SPAN OUTRIGGERS**

**RANGE DIAGRAM WITH OUTRIGGERS AT MID-SPAN POSITION**

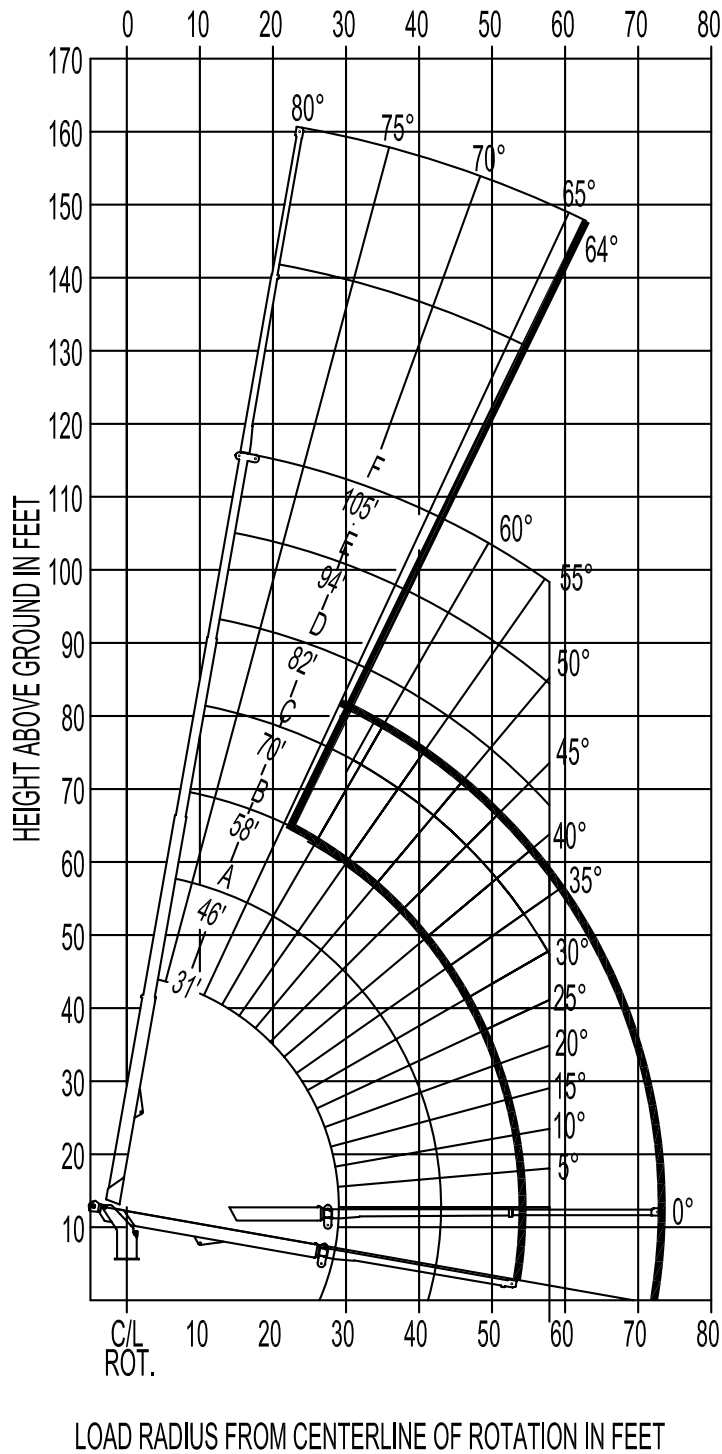

**TRUCK CHASSIS SPECIFICATIONS**

	30105R BoomTruck
Wheelbase (WB)	256" / 650 cm
Cab to Trunnion (CT)	192" / 488 cm
Cab to End of Frame (EOF)	286" / 726 cm
Frame Section Modulus	30.0 in3-110,000 psi
Front Axle Gross Weight Rating	20,000 lb / 9072 kg
Rear Axle Gross Weight Rating	40,000 lb / 18 144 kg
Integral Front Frame Rails	Required for Front Stabilizer

Chassis data is minimum general requirements-not for engineering.  
 Actual dimensions and truck data will depend on truck selection and axle configuration.  
 \*Minimum chassis weight is required to meet 85% stability requirements.

**OPTIONS**



**Radio Remote Control**

Interference protected radio remotes let you get closer to your work and have full control over your machine. Includes battery charging feature and optional LMI screen.



**Tool Boxes**

Optional tool boxes and bed storage can accommodate any storage need for tools, work materials and more.

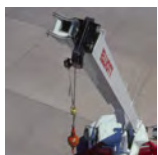

**Pin-On Jib Attachments**

One piece & two piece telescoping or fixed jibs that stow on the side of the boom for easy placement while on the worksite.

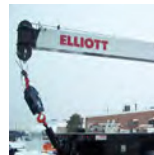

**Hook Block for Multi-Part Line**

Elliott can install a 2-3 part hook block or a 4 part-hook block to improve lifting capabilities. The block can be stored at the rear of the bed.



**Hydraulic Oil Cooler**

Add a bed-mounted hydraulic oil cooler to assist with high duty cycle job applications.



**Gravity Levelled Basket**

Elliott's pin-on work platform pins onto the boom or jib for easy installation and removal. Gravity leveling and mechanical rotation makes it a great accessory for any worksite.



**Digger / Auger Attachment**

Dig faster and deeper with Elliott's auger attachment, offering 44' of digging range and a hydraulically powered auger that stows on the boom.

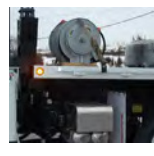

**Body Mounted Hose Reels and Circuits**

Let us work with you to customize your tool compatibility by adding hose reels or hydraulic circuits to the crane bed.

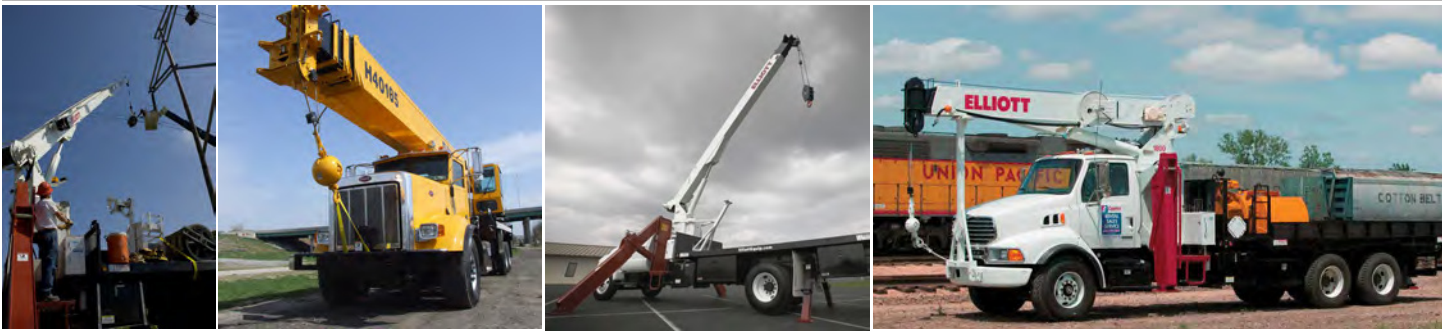

### 30105F-D SIDE VIEW DIAGRAM

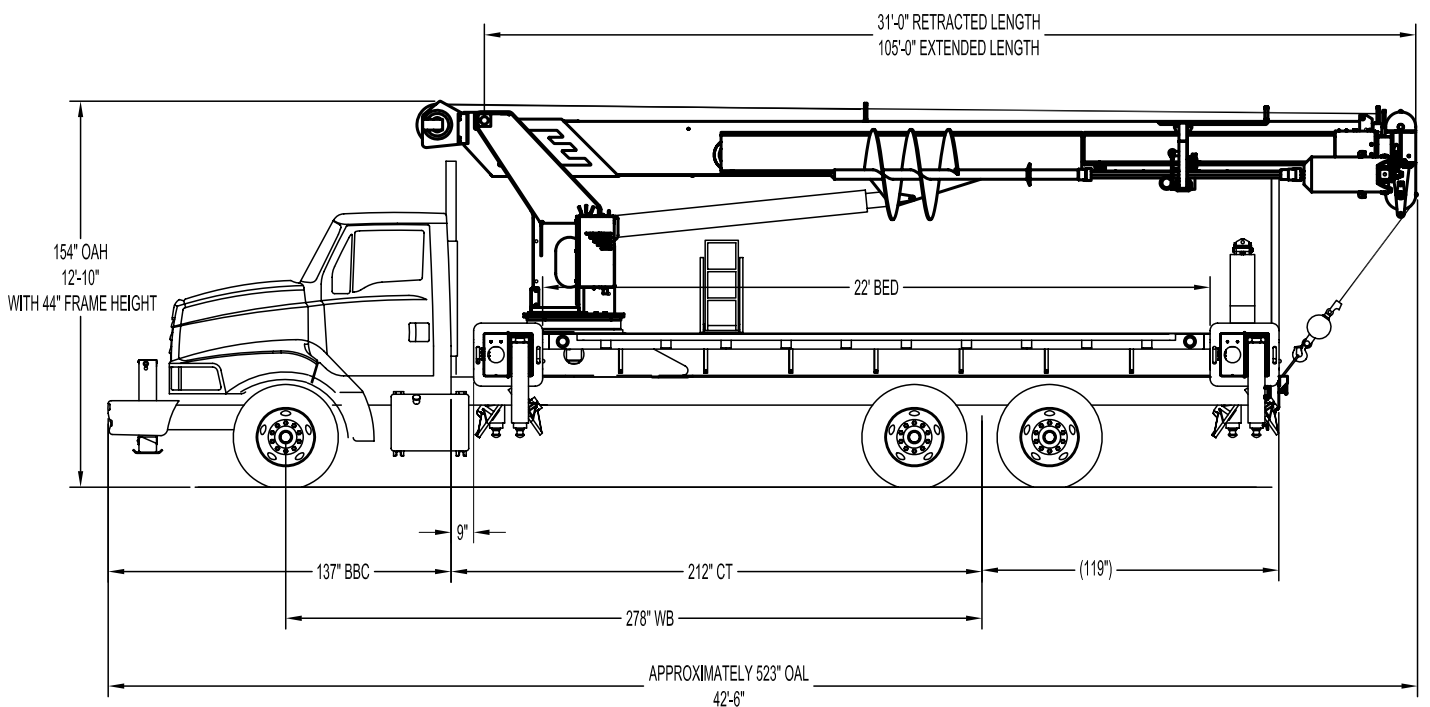

- **Maximum Vertical Reach** 162'/49 m
- **Working Area** 180 Degrees Standard (360 Optional)
- **Lifting Capacity** 60,000 lbs/27 216 kg
- **Boom Length** 105'/32 m
- **Crane Weight (Standard)** 29,785 lbs/13 510 kg
- **Jib Lengths** 26', 26-45'/ 8-14 m
- **Winch Bare Drum Pull** 12,800 lbs/5806 kg
- **Hydraulic Digger Radius** 44'/13,4 m

- **Powered Boom Sections** 4
- **Overall Height** 13'7/4 m
- **Operator Controls** Rotating Standup
- **Outrigger Type Front** Out-Down
- **Outrigger Spread Front** 20'6 m
- **Outrigger Type Rear** Out-Down
- **Outrigger Spread Rear** 20'6 m

## TECHNICAL SPECIFICATIONS

**Crane Capacity:** 60,000 lbs at 5' load radius.

**Maximum Tip Height:** 117' height (162' with optional 45' jib)

**Control Console:** Rotating turret single operator standup control station equipped with four single axis control levers for the main crane controls. Operator station includes LMI display, bubble level gauge, engine start/stop switch, signal horn button, variable speed throttle switch, lifting capacity chart, range diagram chart, boom angle indicator, system pressure gauge, 12V DC power source, and cup holder. Independent ground level electric operated outrigger controls.

**Boom:** Four-section fully proportional, high strength steel plated rectangular tube sections. A maximum boom tip height of 117' mounted on a truck. The boom nose contains one floating upper sheave and three lower sheaves. Assembly includes heavy-duty cylinder fittings, pivot pins, and replaceable wear pads.

**Winch:** Mounted at the base of the boom for a long fleet angle and flat level spooling of cable. Winch is driven by a planetary reducer and powered by a hydraulic motor. The winch brake is spring applied, pressure release design. Supplied with 425' of 9/16" diameter rotation resistant wire rope with a single line pull of 9,060 pounds, and a downhaul ball with swivel hook for single part line.

**Auger System:** 20,000 lb. automatic two-speed auger with 2 5/8" hex drive mounted at end of boom. Auger equipped with a 2 5/8" Kelly bar (auger extension bar) able to accept 24", 36", or 48" flightings. Auger and flighting to be stowed on side of boom from controls operated at main control station. Up to a 36" flighting to be stowed during transport. The auger provides a 44' digging radius. Auger will be provided with alternate radio remote control

Elliott Equipment Company reserves the right to change the specification of any unit at any time without prior notice. This brochure is only a statement of general specifications on the date of this publication. For more detailed info on specific Elliott trucks go to [www.elliottequip.com](http://www.elliottequip.com)

system with integral LMI display in radio transmitter.

**Load Moment Indicator System:** System senses hoist cylinder pressures, boom length and boom angle with hydraulic function lockout. The display console is equipped with a bar graph showing crane utilization, boom angle or boom length, a mode select controls for main boom and jib operation, and an anti-two block with an audio/visual warning and shut-off functions to limit hook-boom point contact.

**Outriggers:** Two sets of out and down overframe outriggers with 20' span. Outriggers are configured for full span or mid span operation. Outriggers equipped with ball socket aluminum removable pads that stow on vertical outrigger legs. Front stabilizer provides 360 degree area of operation.

**Frame:** Full length, all welded rigid 4-plate design sub-frame. Sub-frame allows for bolt-on addition of 22' bed wings, with top plate of subbase serving as a portion of the bed deck, to form a three-piece bed.

**Turret:** Reverse offset turret is one-piece weldment. Turret rotates on large diameter ball bearing.

**Rotation:** Hydraulic motor drives turret through double reduction planetary swing drive for 372-degree non-continuous rotation.

**Lift:** One double-acting long stroke cylinder provides smooth and stable boom elevation. Holding valve prevents boom from falling in event of hose failure.

**Boom Extension:** Incorporates a 2-stage hydraulic extension cylinder, attached to the largest boom section, with a proportional cable extension system driving the outermost sections.

**Hoses:** All high pressure hoses are wire braid reinforced with a minimum safety factor of 4 to 1.

**Cylinders:** All cylinders use microhoned cylinder tubing, chrome shafts, top grade packing and protective rod wipers. Cylinder-mounted holding valves provided on all load-holding cylinders.

**Hydraulic System:** Equipped with air-shift PTO, piston pump, SAE O-ring face seals on pressure lines, and a 10-micron return line filter. The control valve distributes all flow to hoist system, swing circuit, and other crane functions. System is closed center type.

**Oil Tank Capacity:** 120 gallon mounted to truck frame on streetside.

**Cab Equipment:** PTO switch with indicator lights installed in truck cab. U/L approved 5:BC dry chemical fire extinguisher installed in truck cab.

**Operators Manual & Video:** Two CD copies and one hard copy of operation, maintenance, safety and parts manual provided with each unit. Operational and safety video provided at delivery.

**Installation:** Unit installed on chassis, painted, system and tank filled with oil, tested, inspected, and ready to operate.

**Standard Paint:** Paint turret and boom white, outriggers red, and bed and boxes black. Top of bed painted with black nonskid surface.

**Bumper:** Bureau of Motor Carrier Safety rear bumper.

**Weight:** Approximately 29,785 lbs. with 22' steel-floor bed less truck.

**Truck Chassis Required:** Approx. 204" C.T. RBM 3,300,000 in-lb. per rail, 20,000 lb. front axle and 60,000 lb. GVWR required. Trucks must have front frame extension, 12V electrical system with high capacity alternator, cab clearance stop/tail/backup lights, and I.D. lamps. Recommended GVWR is minimum for BoomTruck with flatbed only. Contact factory when additional equipment is to be added.

**LOAD CHART - MAIN BOOM + DIGGER, FULL-SPAN OUTRIGGERS**



**MODEL 3000 105-ft BOOM WITH DIGGER**

**MAIN BOOM LOAD RATINGS WITH FULLY EXTENDED OUTRIGGERS**

MAIN BOOM LOAD RATINGS													JIB LOAD RATINGS									
LOAD RATINGS IN lbs WITH OUTRIGGERS AND STABILIZERS EXTENDED													LOAD RATINGS IN lbs WITH OUTRIGGERS AND STABILIZERS EXTENDED									
LOAD RADIUS IN FEET	LOADED BOOM ANGLE	31-ft		46-ft		58-ft		70-ft		82-ft		94-ft		105-ft		26-ft FIXED LENGTH JIB			26-45 ft EXTENDABLE JIB			
		LOAD RADIUS IN FEET	LOADED BOOM ANGLE	LOAD RADIUS IN FEET	LOADED BOOM ANGLE	LOAD RADIUS IN FEET	LOADED BOOM ANGLE	LOAD RADIUS IN FEET	LOADED BOOM ANGLE	LOAD RADIUS IN FEET	LOADED BOOM ANGLE	LOAD RADIUS IN FEET	LOADED BOOM ANGLE	LOAD RADIUS IN FEET	LOADED BOOM ANGLE	LOAD RADIUS IN FEET	LOADED BOOM ANGLE	26-ft JIB	26-ft JIB RETRACTED	45-ft JIB EXTENDED		
5	80	58,650																				
6	78	46,650																				
8	74.2	37,250	79.2	31,050																		
10	70.3	30,650	76.6	27,050																		
12	66.2	26,150	74	25,050	77.4	24,550																
14	62	22,650	71.3	23,050	75.4	22,950	78	21,050														
16	57.6	19,450	68.6	21,550	73.3	21,450	76.3	19,750	78.3	16,950												
18	52.9	16,550	65.8	20,050	71.1	19,850	74.5	18,350	76.9	16,050	78.6	14,500										
20	47.8	14,250	62.9	18,050	69	18,350	72.8	17,150	75.4	14,950	77.3	13,100										
22	42.3	11,750	60	16,050	66.8	16,850	71	15,850	74	13,950	76.1	12,300	78	7,950								
25	32.2	8,850	55.3	13,050	63.5	14,550	68.4	13,950	71.7	12,450	74.2	11,300	76.1	7,950								
30			46.9	10,050	58.1	11,550	64.2	10,850	68.3	10,950	71.2	9,700	73.2	7,950								
35			37.8	8,050	51.8	9,150	59.4	8,650	64.4	8,750	67.9	8,400	70.3	7,950								
40			24.3	5,350	44.9	7,950	54.4	7,050	60.3	7,100	64.5	7,150	67.4	6,900								
45					36.9	6,750	49	5,850	56.1	5,900	61	5,900	64.3	5,800								
50					26.7	5,250	43.1	4,850	51.7	4,900	57.4	4,900	61.2	4,750								
55							36.3	4,050	46.9	4,100	53.6	4,100	58	3,750								
60							28.1	3,400	41.7	3,450	49.6	3,450	54.6	2,850								
65							16.1	2,850	35.9	2,900	45.4	2,900	51.1	2,500								
70									30	2,450	40.7	2,300	47.4	1,900								
75									19.9	1,750	35.6	1,500	43.5	1,400								
80											29.7	500	39.2	1,000								
85											22.3	100	34.5	700								
90													29.1	400								
95													22.4	150								
0		7,450	0	5,250	0	3,350																
DEDUCTIONS FOR STOWED JIB (lbs)		850		600		450		400		350		300		250								
		550		350		300		250		200		150		150								

ELLIOTT EQUIPMENT CO. SUPPLIED  
 LOADLINE EQUIPMENT DEDUCTIONS:  
 DOWNHAUL WEIGHT .....180 lbs  
 ONE SHEAVE BLOCK.....375 lbs  
 TWO SHEAVE BLOCK.....640 lbs  
 THREE SHEAVE BLOCK.....870 lbs  
 AUXILIARY SHEAVE.....100 lbs

DEDUCTIONS FOR STOWED JIB (lbs)		DEDUCTIONS FOR STOWED EXTENDABLE JIB (lbs)		DEDUCTIONS FOR STOWED FIXED LENGTH JIB (lbs)		NOTICE	
1-PART LINE	2-PART LINE	3-PART LINE	4-PART LINE	5-PART LINE	6-PART LINE	7-PART LINE	- DO NOT DEAD-END LINE BLOCK AGAINST BOOM TIP WHEN OPERATING BOOM. - KEEP AT LEAST 5 FEET OF CABLE ON THE WINCH DRUM AT ALL TIMES. - USE ONLY THE DIAMETER WIRE ROPE AS SPECIFIED BELOW WITH THE PROPER BREAKING STRENGTHS LISTED. - VERIFY THE LOCK SYSTEM MUST BE ENGAGED BEFORE OPERATING CRANE. SEE OPERATOR'S SAFETY MANUAL. *WIRE ROPES ARE 30% OF S.S. TENSILE BREAKING STRENGTH. **WIRE ROPES ARE 10% OF S.S. TENSILE BREAKING STRENGTH. ***WIRE ROPES ARE 10% OF S.S. TENSILE BREAKING STRENGTH.
MAX PULL: 9,600 lbs	19,200 lbs	28,800 lbs	38,400 lbs	48,000 lbs	57,600 lbs	60,000 lbs	
MAX PULL: 9,060 lbs	18,120 lbs	27,180 lbs	36,240 lbs	45,300 lbs	54,360 lbs	60,000 lbs	



Elliott Equipment Company  
 3514 South 25th Street  
 Omaha, NE 68105  
 Phone: 402-592-4500  
 Fax: 402-592-4553  
 Email: sales@elliottequip.com

**Built for You.**  
 www.elliottequip.com

**LOAD CHART - MAIN BOOM + DIGGER, MID-SPAN OUTRIGGERS**



**MODEL 3000 105-ft BOOM WITH DIGGER**

**MAIN BOOM LOAD RATINGS WITH OUTRIGGERS AT MID-SPAN POSITION**

**MAIN BOOM LOAD RATINGS**

LOAD RATINGS IN lbs WITH OUTRIGGERS AND STABILIZERS EXTENDED

LOAD RADIUS IN FEET	LOADED BOOM ANGLE	31-ft	LOADED BOOM ANGLE	A 46-ft	LOADED BOOM ANGLE	B 58-ft	LOADED BOOM ANGLE	C 70-ft	LOADED BOOM ANGLE	D 82-ft	LOADED BOOM ANGLE	E 94-ft	LOADED BOOM ANGLE	F 105-ft
5	80	58,650												
6	78	46,650												
8	74.2	37,250	79.2	31,050										
10	70.3	30,650	76.6	27,050										
12	66.2	26,150	74	25,050	77.4	24,550								
14	62	19,950	71.3	23,050	75.4	22,950	78	21,050						
16	57.6	18,150	68.6	19,050	73.3	19,250	76.3	19,750	78.3	16,950				
18	52.9	14,450	65.8	14,850	71.1	15,850	74.5	15,650	76.9	16,050	78.6	14,500		
20	48.9	10,850	62.9	12,050	69	12,550	72.8	12,750	75.4	13,350	77.3	13,100		
22	42.3	8,150	60	9,550	66.8	10,250	71	10,350	74	10,650	76.1	10,500	78	7,950
25	33.8	6,450	55.3	7,250	63.5	7,550	68.7	8,100	72	8,250	74.2	8,500	76.1	7,950
30			46.9	4,950	58.1	5,350	64.2	5,500	68.3	5,650	71.2	5,900	73.2	6,050
35			37.8	3,050	51.8	3,550	59.4	3,700	64.4	3,850	67.9	4,100	70.3	4,250
40			24.3	1,850	44.9	2,350	54.4	2,500	60.3	2,650	64.5	2,800	67.4	2,950
45					36.9	1,450	49	1,600	56.1	1,750	61	1,900	64.3	2,050
50					26.7	700	43.1	900	51.7	1,050	57.4	1,200	61.2	1,350
55							36.3	350	46.9	500	53.6	650	58	750
60									41.7	100	49.6	200	54.6	300
0		3,850	0	1,250										
DEDUCTIONS FOR STOWED JIB (lbs)		850		600		450		400		350		300		250
		550		350		300		250		200		150		150

**JIB LOAD RATINGS**

LOAD RATINGS IN lbs WITH OUTRIGGERS AND STABILIZERS EXTENDED

LOAD RADIUS IN FEET	LOADED BOOM ANGLE	26-ft FIXED LENGTH JIB		26-45 ft EXTENDABLE JIB	
		26-ft JIB	LOADED BOOM ANGLE	26-ft JIB RETRACTED	LOADED BOOM ANGLE
30	78.7	4,750	78.5	4,500	
35	76.5	4,350	76.3	4,100	77.4 2,600
40	74.3	3,950	74.1	3,600	75.4 2,500
45	72	2,950	71.7	2,700	74 2,400
50	69.5	2,200	69.3	1,900	72.2 2,250
55	67.1	1,550	66.8	1,300	70.3 2,000
60	64.6	1,050	64.3	800	68.3 1,450
65					66.2 1,050
70					64.2 750

ELLIOTT EQUIPMENT CO. SUPPLIED  
LOADLINE EQUIPMENT DEDUCTIONS:  
DOWNHAUL WEIGHT ..... 180 lbs  
ONE SHEAVE BLOCK..... 375 lbs  
TWO SHEAVE BLOCK..... 640 lbs  
THREE SHEAVE BLOCK..... 870 lbs  
AUXILIARY SHEAVE..... 100 lbs

DEDUCTIONS FOR STOWED EXTENDABLE JIB (lbs)  
DEDUCTIONS FOR STOWED FIXED LENGTH JIB (lbs)

**1-PART LINE 2-PART LINE 3-PART LINE 4-PART LINE 5-PART LINE 6-PART LINE 7-PART LINE**

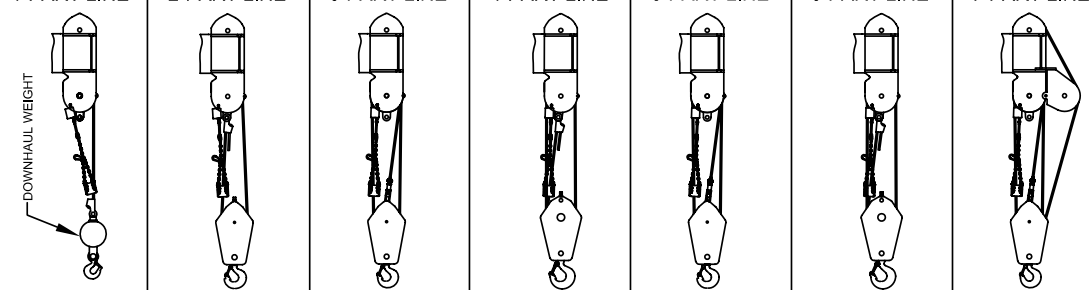

MAX PULL: 9,600 lbs	19,200 lbs	28,800 lbs	38,400 lbs	48,000 lbs	57,600 lbs	60,000 lbs
MAX PULL: 9,060 lbs	18,120 lbs	27,180 lbs	36,240 lbs	45,300 lbs	54,360 lbs	60,000 lbs

**NOTICE**  
- DO NOT DEADHEAD LINE BLOCK AGAINST BOOM TIP WHEN EXTENDING BOOM.  
- KEEP AT LEAST 5 WRAPS OF LOADLINE ON THE WINCH DRUM AT ALL TIMES.  
- USE ONLY 9/16" DIAMETER WIRE ROPE, AS SPECIFIED BELOW, WITH THE PROPER BREAKING STRENGTHS LISTED.  
- ANTI-TWO-BLOCK SYSTEM MUST BE IN GOOD OPERATING CONDITION BEFORE OPERATING CRANE. SEE OPERATION & SAFETY MANUAL.  
9/16" - 6 x 37 IWRC (3.5:1 S.F.) 33,600-lbs. BREAKING STRENGTH  
9/16" - SPIN RESISTANT (S:1 S.F.) 45,300-lbs. BREAKING STRENGTH

CRANE MEETS ASME B30.5 REQUIREMENTS AT TIME OF MANUFACTURE DO NOT PAINT OVER ANY LABELS 1148880 111308



Elliott Equipment Company  
3514 South 25th Street  
Omaha, NE 68105  
Phone: 402-592-4500  
Fax: 402-592-4553  
Email: sales@elliottequip.com

**Built for You.**  
www.elliottequip.com

**RANGE CHART - MAIN BOOM + JIB, FULL-SPAN OUTRIGGERS**



**MODEL 3000 105-ft BOOM WITH DIGGER**

**RANGE DIAGRAM WITH FULL SPAN OUTRIGGERS**

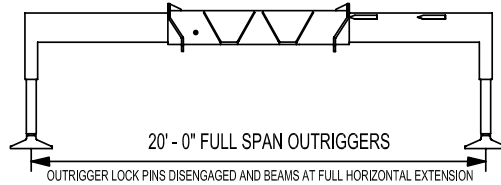
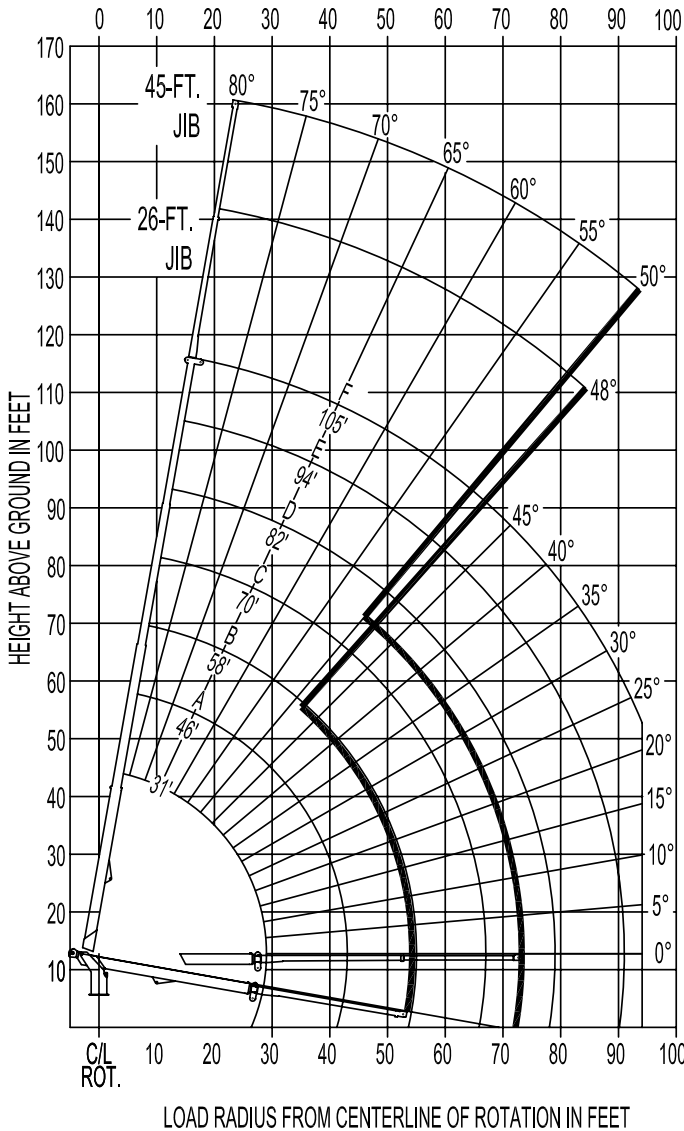

**NOTE:**

1. Operate jib by radius when main boom is full extended. Increase boom angle if necessary to maintain load radius.
2. When boom is retracted, operate jib by boom angles. Do not exceed any rated jib capacities at reduced boom lengths.
3. Capacities do not exceed 85% stability.
4. Load ratings above bold line are structurally limited.
5. Personnel handling is allowed only with full span outriggers.
6. Boom load ratings are based on loaded boom radius. Loaded boom angles are given as reference only.

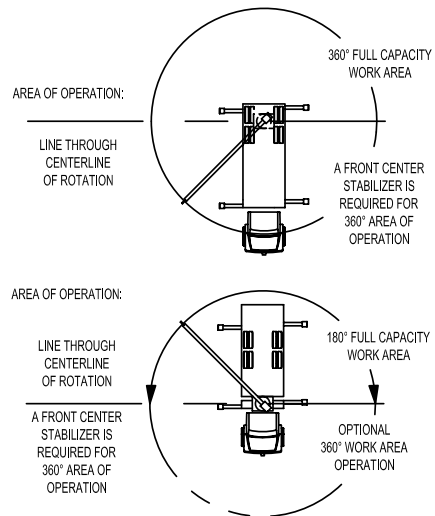

DO NOT PAINT OVER ANY LABELS 1148880 111308

**RANGE CHART - MAIN BOOM + JIB, MID-SPAN OUTRIGGERS**



**MODEL 3000 105-ft BOOM WITH DIGGER**

**RANGE DIAGRAM WITH OUTRIGGERS AT MID-SPAN POSITION**

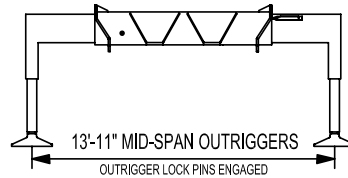
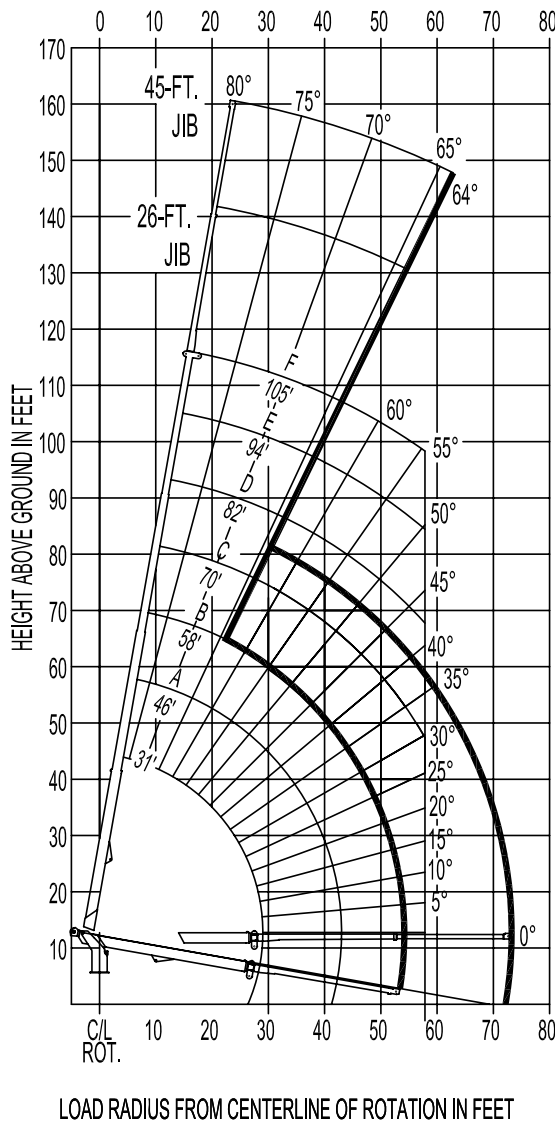

**NOTE:**

1. Operate jib by radius when main boom is full extended. Increase boom angle if necessary to maintain load radius.
2. When boom is retracted, operate jib by boom angles. Do not exceed any rated jib capacities at reduced boom lengths.
3. Capacities do not exceed stability based on ISO 4305-1991.
4. Load ratings above bold line are structurally limited.
5. Personnel handling is allowed only with full span outriggers.
6. Boom load ratings are based on loaded boom radius. Loaded boom angles are given as reference only.

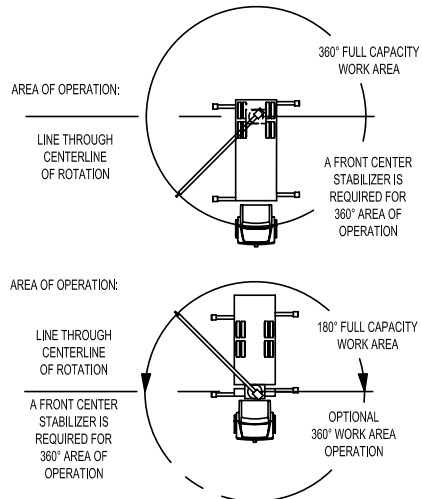

DO NOT PAINT OVER ANY LABELS 1148880 111308

## TRUCK CHASSIS SPECIFICATIONS

	30105F-D BoomTruck
Wheelbase (WB)	268" / 681 cm
Cab to Tandem (CT)	204" / 518 cm
Cab to End of Frame (EOF)	334" / 594 cm
Frame Section Modulus	30.0 in3-110,000 psi
Front Axle Gross Weight Rating	20,000 lb / 9,071 kg
Rear Axle Gross Weight Rating	40,000 lb / 18,143 kg
Integral Front Frame Rails	Required for Front Stabilizer

Chassis data is minimum general requirements-not for engineering.  
Actual dimensions and truck data will depend on truck selection and axle configuration.  
\*Minimum chassis weight is required to meet 85% stability requirements.

## OPTIONS



### Hydraulic Pole Claw

Combine Elliott's digger system with a hydraulic pole claw to dig holes and place poles with a single machine.



### Pin-On Jib Attachments

One piece & two piece telescoping or fixed jibs that stow on the side of the boom for easy placement while on the worksite.

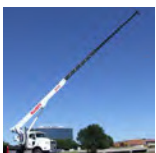

### Continuous Boom Rotation

Add the convenience of 360 degree continuous rotation by adding a special boom rotation bearing for swinging without stops.



### Hydraulic Digger / Auger

Dig faster and deeper with Elliott's selection of auger flightings up to 48" in diameter that provide an industry-leading 44' digging radius and more power out of the hole.



### Tool Boxes

Optional tool boxes and bed storage can accommodate any storage need for tools, work materials and more.

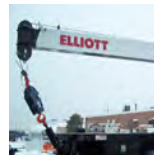

### Hook Block for Multi-Part Line

Elliott can install a 2-3 part hook block or a 4 part-hook block to improve lifting capabilities. The block can be stored at the rear of the bed.

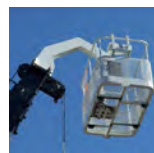

### Gravity Leveled Basket

Elliott's pin-on work platform pins onto the boom for easy installation and removal. Gravity leveling and mechanical rotation makes it a great accessory for any worksite.

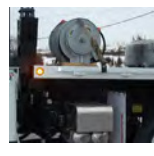

### Body Mounted Hose Reels and Circuits

Let us work with you to customize your tool compatibility by adding hose reels or hydraulic circuits to the crane bed.

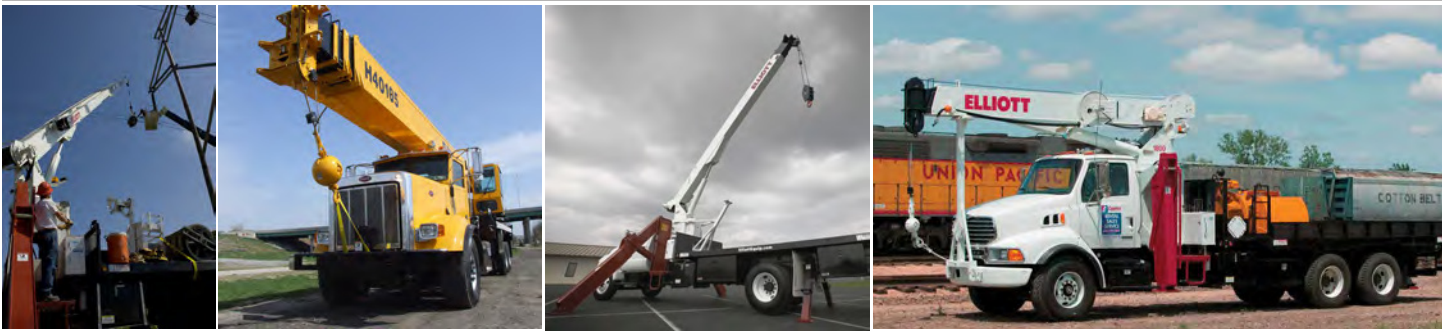

### 32117F SIDE VIEW DIAGRAM

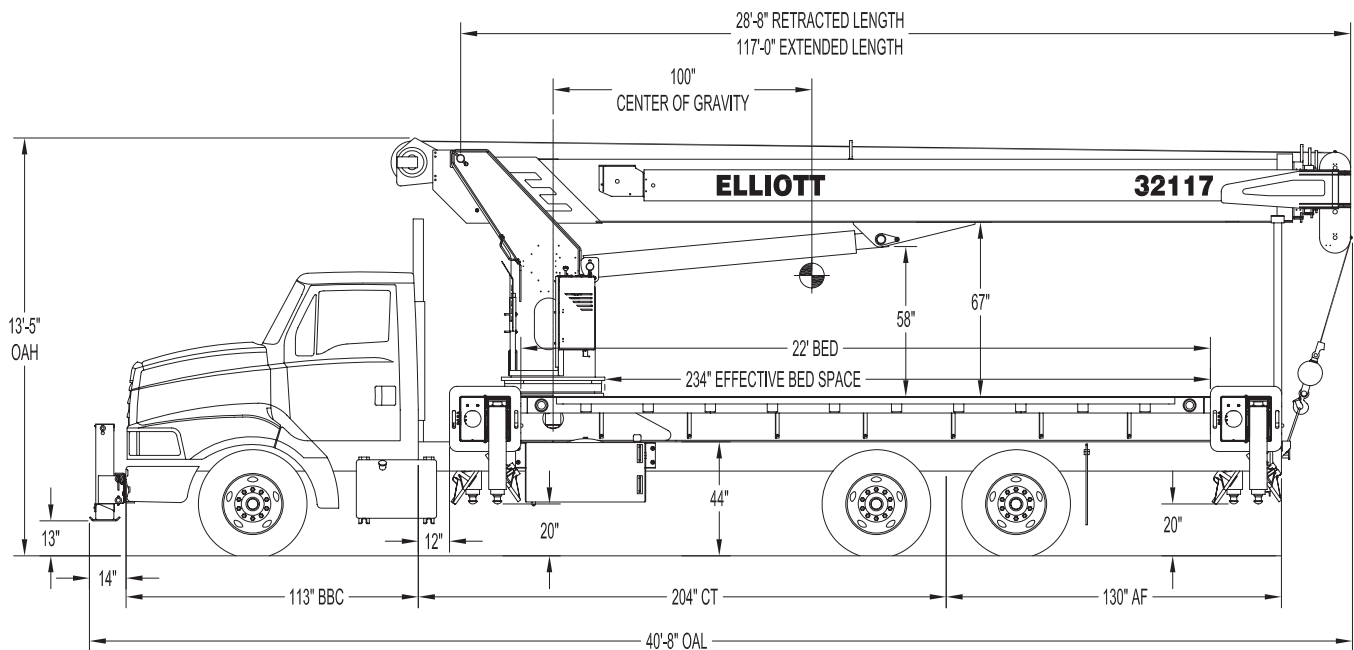

- |                                  |                                     |                                 |                              |
|----------------------------------|-------------------------------------|---------------------------------|------------------------------|
| • <b>Maximum Vertical Reach</b>  | 153' / 46,6 m                       | • <b>Powered Boom Sections</b>  | 5                            |
| • <b>Working Area</b>            | 180 Degrees Standard (360 Optional) | • <b>Overall Height</b>         | 13'5" / 4,1 m                |
| • <b>Lifting Capacity</b>        | 64,000 lbs / 29 030 kg              | • <b>Operator Controls</b>      | Single-Side Rotating Standup |
| • <b>Boom Length</b>             | 117' / 35,6 m                       | • <b>Outrigger Type Front</b>   | Out-Down                     |
| • <b>Crane Weight (Standard)</b> | 30,800 lbs / 13 971 kg              | • <b>Outrigger Spread Front</b> | 20' / 6 m                    |
| • <b>Jib Lengths</b>             | 24' / 7,3 m                         | • <b>Outrigger Type Rear</b>    | Out-Down                     |
| • <b>Winch Bare Drum Pull</b>    | 12,800 lbs / 5806 kg                | • <b>Outrigger Spread Rear</b>  | 20' / 6 m                    |

## TECHNICAL SPECIFICATIONS

**Crane Capacity:** 64,000 lbs at 5' load radius.

**Maximum Tip Height:** 129' height (153' with optional 24' jib)

**Control Console:** Rotating turret single operator standup control station equipped with four single axis control levers for the main crane controls. Operator station includes LMI display, bubble level gauge, engine start/stop switch, signal horn button, variable speed throttle switch, lifting capacity chart, range diagram chart, boom angle indicator, system pressure gauge, 12V DC power source, and cup holder. Independent ground level electric operated outrigger controls.

**Boom:** Five-section fully proportional, high strength steel plated rectangular tube sections. A maximum boom tip height of 129' mounted on a truck. The boom nose contains one floating upper sheave and three lower sheaves. Assembly includes heavy-duty cylinder fittings, pivot pins, and replaceable wear pads.

**Winch:** Mounted at the base of the boom for a long fleet angle and flat level spooling of cable. Winch is driven by a planetary reducer and powered by a hydraulic motor. Burst-of-speed winch provides increased line speed. The winch brake is spring applied, pressure release design. Supplied with 425' of 9/16" diameter rotation resistant wire rope with a single line pull of 9,060 pounds, and a downhaul ball with swivel hook for single part line.

**Load Moment Indicator System:**

System senses hoist cylinder pressures, boom length and boom angle with hydraulic function lockout. The display console is equipped with a bar graph showing crane utilization, boom angle or boom length, a mode select controls for main boom and jib operation, and an anti-two block with an audio/visual warning and shut-off functions to limit hook-boom point contact.

Elliott Equipment Company reserves the right to change the specification of any unit at any time without prior notice. This brochure is only a statement of general specifications on the date of this publication. For more detailed info on specific Elliott trucks go to [www.elliottequip.com](http://www.elliottequip.com)

**Outriggers:** Two sets of out and down overframe outriggers with 20' span. Outriggers are configured for full span or mid span operation. Outriggers equipped with ball socket aluminum removable pads that stow on vertical outrigger legs.

**Frame:** Full length, all welded rigid 4-plate design sub-frame. Sub-frame allows for bolt-on addition of 22' bed wings, with top plate of subbase serving as a portion of the bed deck, to form a three-piece bed.

**Turret:** Reverse offset turret is one-piece weldment. Turret rotates on large diameter ball bearing.

**Rotation:** Hydraulic motor drives turret through double reduction planetary swing drive for 372-degree non-continuous rotation.

**Lift:** One double-acting long stroke cylinder provides smooth and stable boom elevation. Holding valve prevents boom from falling in event of hose failure.

**Boom Extension:** Incorporates a 2-stage hydraulic extension cylinder, attached to the largest boom section, with a proportional cable extension system driving the outermost sections.

**Hoses:** All high pressure hoses are wire braid reinforced with a minimum safety factor of 4 to 1.

**Cylinders:** All cylinders use microhoned cylinder tubing, chrome shafts, top grade packing and protective rod wipers. Cylinder-mounted holding valves provided on all load-holding cylinders.

**Hydraulic System:** Equipped with air-shift PTO, piston pump, SAE O-ring face seals on pressure lines, and a 10-micron return line filter. The control valve distributes all flow to hoist system, swing circuit, and other crane functions. System is closed center type.

**Oil Tank Capacity:** 120 gallon mounted to truck frame on roadside.

**Cab Equipment:** PTO switch with indicator lights installed in truck cab. U/L approved 5:BC dry chemical fire extinguisher installed in truck cab.

**Operators Manual & Video:** Two CD copies and one hard copy of operation, maintenance, safety and parts manual provided with each unit. Operational and safety video provided at delivery.

**Installation:** Unit installed on chassis, painted, system and tank filled with oil, tested, inspected, and ready to operate.

**Standard Paint:** Paint turret and boom white, outriggers red, and bed and boxes black. Top of bed painted with black nonskid surface.

**Bumper:** Bureau of Motor Carrier Safety rear bumper.

**Weight:** Approximately 30,800 lbs. with 22' steel-floor bed less truck.

**Truck Chassis Required:** Approx. 204" C.A. RBM 3,300,000 in-lb. per rail, 20,000 lb. front axle and 60,000 lb. GVWR required. Trucks must have front frame extension, 12V electrical system with high capacity alternator, cab clearance stop/tail/backup lights, and I.D. lamps. Recommended GVWR is minimum for BoomTruck with flatbed only. Contact factory when additional equipment is to be added.

**Options:**

24' Fixed Jib.

Radio Remote Controls.

Gravity-Leveled and Rotating Steel Basket.

Tool Box Configurations.

Front Jack for 360 Degree Crane Operation.

Much More...

**LOAD CHART - MAIN BOOM, FULL-SPAN OUTRIGGERS**

DO NOT PAINT OVER ANY LABELS 1097740 101705



**MODEL 3200 117-ft BOOM**

**MAIN BOOM LOAD RATINGS WITH FULLY EXTENDED OUTRIGGERS**

**MAIN BOOM LOAD RATINGS**

**JIB LOAD RATINGS**

LOAD RATINGS IN lbs WITH OUTRIGGERS AND STABILIZERS EXTENDED

LOAD RATINGS IN lbs WITH OUTRIGGERS AND STABILIZERS EXTENDED

LOAD RADIUS IN FEET	LOADED BOOM ANGLE	28-ft	LOADED BOOM ANGLE	A	LOADED BOOM ANGLE	B	LOADED BOOM ANGLE	C	LOADED BOOM ANGLE	D	LOADED BOOM ANGLE	E	LOADED BOOM ANGLE	F
		42-ft		42-ft		57-ft		72-ft		87-ft		102-ft		117-ft
5	80	64,000												
6	78	54,000												
8	73.5	42,000												
10	69	35,000	76.5	28,000										
12	64	30,000	73.5	27,500	78.5	25,000								
14	59	26,500	70.5	25,000	76.5	23,600	80	20,000						
16	53.5	23,600	67.5	22,800	74.5	22,200	78.5	19,000						
18	47.5	20,000	64.5	20,400	72.5	20,600	77	18,200	80	16,100				
20	41	16,500	61	18,000	70	19,100	75	17,000	78	14,500				
25			52	14,000	64.5	14,300	71	14,000	75	13,000	78	11,800	79	7,200
30			42	10,000	58	10,950	66	11,000	71.5	11,200	75	10,200	77	7,200
35					52	8,650	62	8,800	68	8,850	72	8,900	75	7,200
40					45	7,000	57	7,100	64	7,200	69	7,250	72.5	7,200
45					36.5	5,600	52	5,800	60	5,900	65.5	5,950	69.5	6,000
50							46	4,750	56	4,850	62.5	4,900	67	4,950
55							40	3,900	55.5	4,000	59	4,000	64	4,100
60							32	2,800	47	3,200	55.5	3,250	61	3,250
65							22.5	2,400	42	2,600	51.5	2,750	58	2,750
70									36	2,000	47.5	2,150	54.5	2,150
75									29.5	1,400	43	1,600	51.5	1,650
80											38.5	1,000	47.5	1,200
85											33.5	800	44	800
90													40	500
0		8,500	0	4,700	0	2,600								

24-ft FIXED LENGTH JIB		
LOAD RADIUS IN FEET	LOADED BOOM ANGLE	24-ft JIB
30	79	4,000
35	77	3,900
40	75	3,750
45	73	3,450
50	71	3,050
55	68.5	2,650
60	66.5	2,350
65	64	2,050
70	62	1,850
75	59.5	1,650
80	57	1,450
85	54.5	1,150
90	51.5	800
95	48.5	500

**NOTICE**

- DO NOT DEADHEAD LINE BLOCK AGAINST BOOM TIP WHEN EXTENDING BOOM.
- KEEP AT LEAST 5 WRAPS OF LOADLINE ON THE WINCH DRUM AT ALL TIMES.
- USE ONLY 9/16" DIAMETER WIRE ROPE, AS SPECIFIED BELOW, WITH THE PROPER BREAKING STRENGTHS LISTED.
- ANTI-TWO-BLOCK SYSTEM MUST BE IN GOOD OPERATING CONDITION BEFORE OPERATING CRANE. SEE OPERATION & SAFETY MANUAL.

DEDUCTIONS FOR STOWED JIB (lbs)	550	350	300	250	200	150	100
---------------------------------	-----	-----	-----	-----	-----	-----	-----

DEDUCTIONS FOR STOWED FIXED LENGTH JIB (lbs)

1-PART LINE 	2-PART LINE 	3-PART LINE 	4-PART LINE 	5-PART LINE 	6-PART LINE 	7-PART LINE 
MAX PULL: 9,060 lbs	18,120 lbs	27,180 lbs	36,240 lbs	45,300 lbs	54,360 lbs	64,000 lbs

ELLIOTT EQUIPMENT CO. SUPPLIED LOADLINE EQUIPMENT DEDUCTIONS:  
 DOWNSHAUL WEIGHT .....180 lbs  
 ONE SHEAVE BLOCK.....375 lbs  
 TWO SHEAVE BLOCK.....640 lbs  
 THREE SHEAVE BLOCK.....870 lbs  
 AUXILIARY SHEAVE.....100 lbs

9/16" - SPIN RESISTANT (5:1 S.F.)  
 45,300-lbs, BREAKING STRENGTH

CRANE MEETS ASME B30.5 REQUIREMENTS AT TIME OF MANUFACTURE



Elliott Equipment Company  
 3514 South 25th Street  
 Omaha, NE 68105  
 Phone: 402-592-4500  
 Fax: 402-592-4553  
 Email: sales@elliottequip.com

**Built for You.**  
 www.elliottequip.com

**LOAD CHART - MAIN BOOM, MID-SPAN OUTRIGGERS**



**MODEL 3200 117-ft BOOM**

**MAIN BOOM LOAD RATINGS WITH OUTRIGGERS AT MID-SPAN POSITION**

**MAIN BOOM LOAD RATINGS**

**JIB LOAD RATINGS**

LOAD RATINGS IN lbs WITH OUTRIGGERS AND STABILIZERS EXTENDED

LOAD RATINGS IN lbs WITH OUTRIGGERS AND STABILIZERS EXTENDED

LOAD RADIUS IN FEET	LOADED BOOM ANGLE	28-ft	LOADED BOOM ANGLE	A 42-ft	LOADED BOOM ANGLE	B 57-ft	LOADED BOOM ANGLE	C 72-ft	LOADED BOOM ANGLE	D 87-ft	LOADED BOOM ANGLE	E 102-ft	LOADED BOOM ANGLE	F 117-ft
5	80	64,000												
6	78	54,000												
8	73.5	42,000												
10	69	35,000	76.5	28,000										
12	64	30,000	73.5	27,500	78.5	25,000								
14	59	26,500	70.5	25,000	76.5	23,600	80	20,000						
16	53.5	21,700	67.5	22,500	74.5	22,200	78.5	19,000						
18	47.5	16,800	64.5	17,500	72.5	18,000	77	18,200	80	16,100				
20	41	13,500	61	14,000	70	14,500	75	14,800	78	14,500				
25			52	8,800	64.5	9,200	71	9,400	75	9,500	78	9,500	79	7,200
30			42	5,800	58	6,150	66	6,300	71.5	6,400	75	6,450	77	6,500
35					52	4,200	62	4,350	68	4,450	72	4,500	75	4,550
40					45	2,850	57	3,000	64	3,100	69	3,150	72.5	3,150
45					36.5	1,800	52	2,000	60	2,100	65.5	2,100	69.5	2,150
50							46	1,200	56	1,300	62.5	1,350	67	1,350
	0	5,000	0	2,000										

**24-ft FIXED LENGTH JIB**

LOAD RADIUS IN FEET	LOADED BOOM ANGLE	24-ft JIB
30	79	4,000
35	77	3,900
40	75	2,850
45	73	1,850
50	71	1,100
55	68.5	500

**NOTICE**

- DO NOT DEADHEAD LINE BLOCK AGAINST BOOM TIP WHEN EXTENDING BOOM.
- KEEP AT LEAST 5 WRAPS OF LOADLINE ON THE WINCH DRUM AT ALL TIMES.
- USE ONLY 9/16" DIAMETER WIRE ROPE, AS SPECIFIED BELOW, WITH THE PROPER BREAKING STRENGTHS LISTED.
- ANTI-TWO-BLOCK SYSTEM MUST BE IN GOOD OPERATING CONDITION BEFORE OPERATING CRANE. SEE OPERATION & SAFETY MANUAL.

DEDUCTIONS FOR STOWED JIB (lbs)	550	350	300	250	200	150	100
---------------------------------	-----	-----	-----	-----	-----	-----	-----

DEDUCTIONS FOR STOWED FIXED LENGTH JIB (lbs)

1-PART LINE	2-PART LINE	3-PART LINE	4-PART LINE	5-PART LINE	6-PART LINE	7-PART LINE
MAX PULL: 9,060 lbs	18,120 lbs	27,180 lbs	36,240 lbs	45,300 lbs	54,360 lbs	64,000 lbs

ELLIOTT EQUIPMENT CO. SUPPLIED LOADLINE EQUIPMENT DEDUCTIONS:  
 DOWNHAUL WEIGHT .....180 lbs  
 ONE SHEAVE BLOCK.....375 lbs  
 TWO SHEAVE BLOCK.....640 lbs  
 THREE SHEAVE BLOCK.....870 lbs  
 AUXILIARY SHEAVE.....100 lbs

9/16" - SPIN RESISTANT (6:1 S.F.)  
 45,300-lbs. BREAKING STRENGTH

CRANE MEETS ASME B30.5 REQUIREMENTS AT TIME OF MANUFACTURE

DO NOT PAINT OVER ANY LABELS

1097740 101705



Elliott Equipment Company  
 3514 South 25th Street  
 Omaha, NE 68105  
 Phone: 402-592-4500  
 Fax: 402-592-4553  
 Email: sales@elliottequip.com

**Built for You.**  
[www.elliottequip.com](http://www.elliottequip.com)

**RANGE CHART - MAIN BOOM + JIB, FULL-SPAN OUTRIGGERS**



**MODEL 3200 117-ft BOOM**

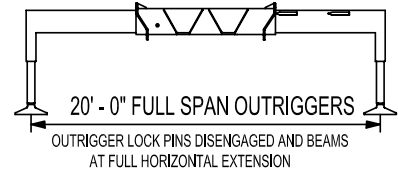
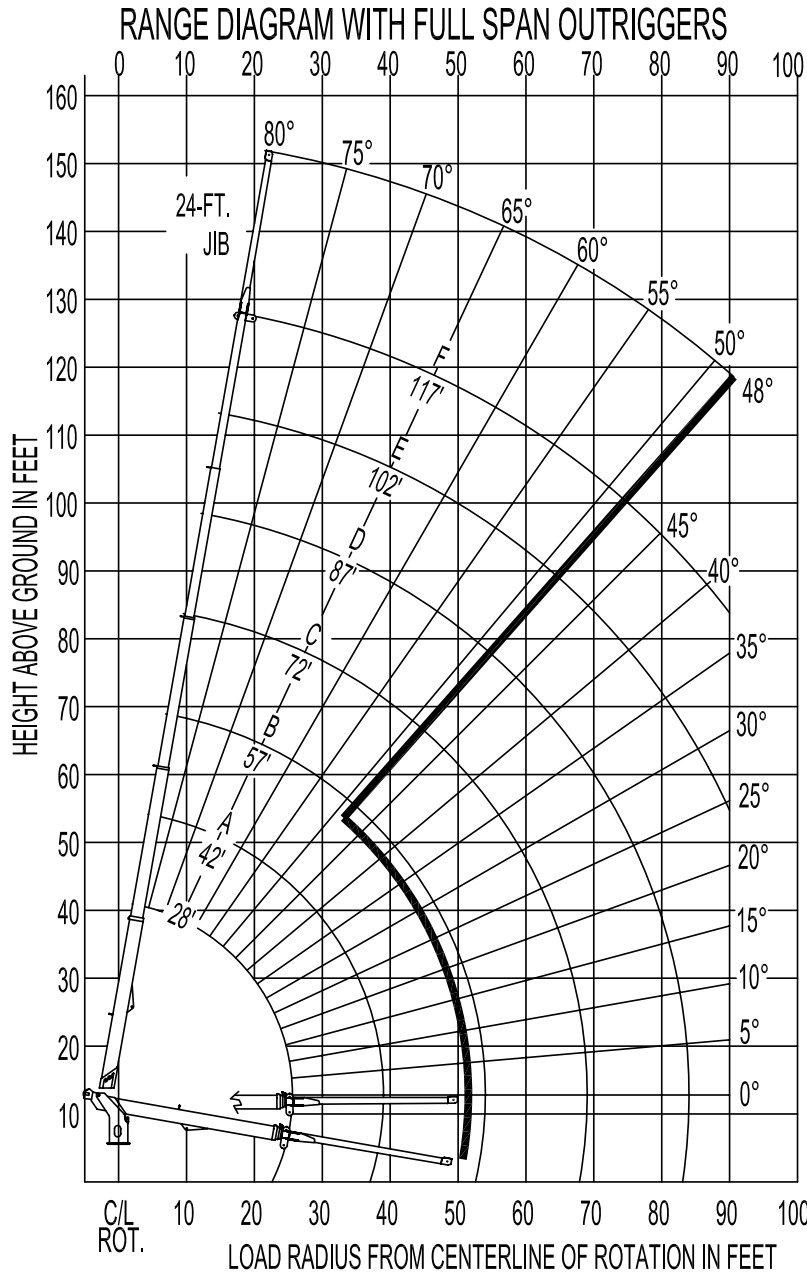

**NOTE:**

1. Operate jib by radius when main boom is fully extended. Increase boom angle if necessary to maintain load radius.
2. When boom is retracted, operate jib by boom angle. Do not exceed any rated jib capacities at reduced boom lengths.
3. Capacities do not exceed 85% stability.
4. Load ratings above bold line are structurally limited.
5. Personnel handling is allowed only with full span outriggers.
6. Boom load ratings are based on loaded boom radius. Loaded boom angles are given as reference only.

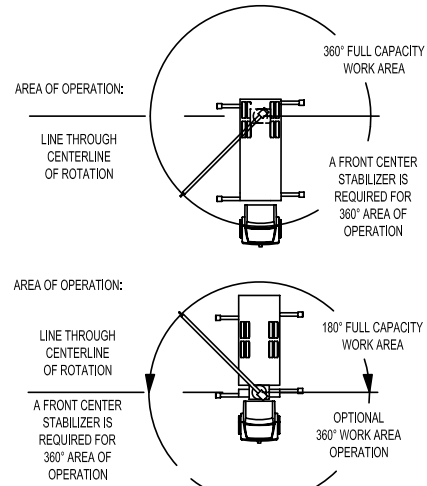

DO NOT PAINT OVER ANY LABELS 1097740 101705

**LOAD CHART - MAIN BOOM + JIB, MID-SPAN OUTRIGGERS**



**MODEL 3200 117-ft BOOM**

**RANGE DIAGRAM WITH MID-SPAN OUTRIGGERS**

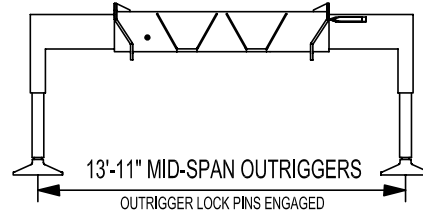
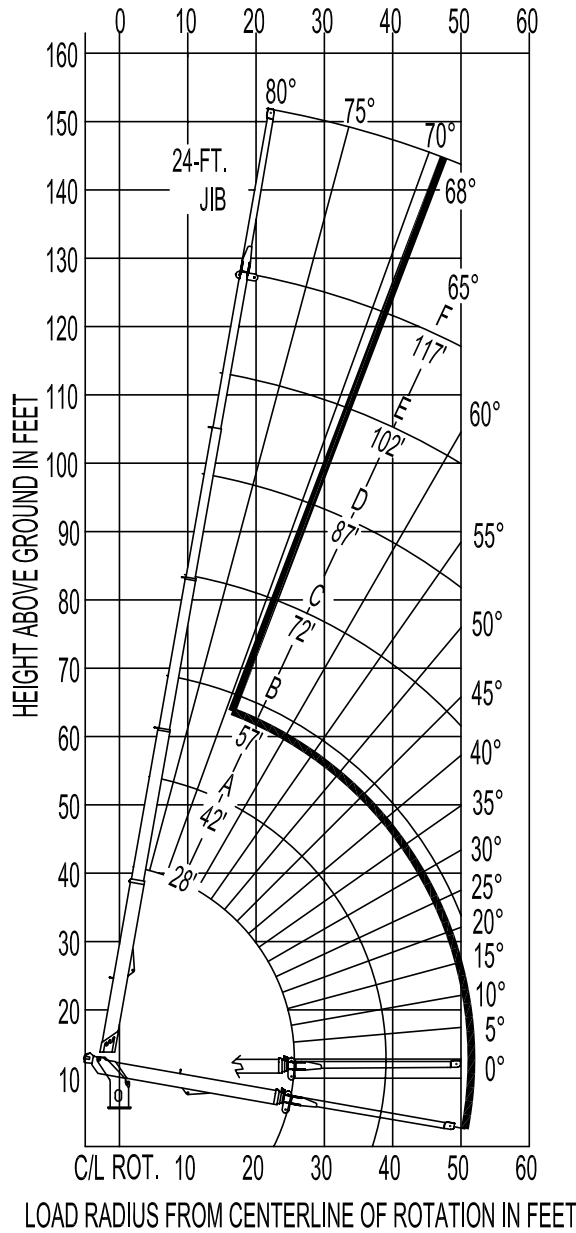

**NOTE:**

1. Operate jib by radius when main boom is full extended. Increase boom angle if necessary to maintain load radius.
2. When boom is retracted, operate jib by boom angles. Do not exceed any rated jib capacities at reduced boom lengths.
3. Capacities do not exceed 85% stability.
4. Load ratings above bold line are structurally limited.
5. Personnel handling is allowed only with full span outriggers.
6. Boom load ratings are based on loaded boom radius. Loaded boom angles are given as reference only.

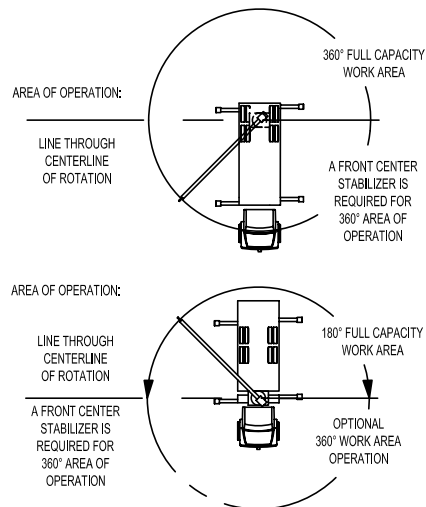

DO NOT PAINT OVER ANY LABELS

1097740 101705

## TRUCK CHASSIS SPECIFICATIONS

	32117F BoomTruck
Wheelbase (WB)	268" / 681 cm
Cab to Tandem (CT)	204" / 518 cm
Cab to End of Frame (EOF)	334" / 594 cm
Frame Section Modulus	30.0 in3-110,000 psi / 492 cm3-758,428 kPa
Front Axle Gross Weight Rating	20,000 lb / 9071 kg
Rear Axle Gross Weight Rating	40,000 lb / 18 143 kg
Integral Front Frame Rails	Required for Front Stabilizer

Chassis data is minimum general requirements-not for engineering.  
 Actual dimensions and truck data will depend on truck selection and axle configuration.  
 \*Minimum chassis weight is required to meet 85% stability requirements.

## OPTIONS



### Radio Remote Control

Interference protected radio remotes let you get closer to your work and have full control over your machine. Includes battery charging feature and optional LMI screen.



### Pin-On Jib Attachment

One piece fixed jib that stow on the side of the boom for easy placement while on the worksite.

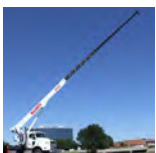

### 360 Degree Area of Operation

Add the convenience of 360 degree area of operation by adding a front stabilizer for working around the entire crane.



### Hydraulic Oil Cooler

Add a bed-mounted hydraulic oil cooler and fan to assist with high duty cycle job applications. A "must" for hot weather environments



### Tool Boxes

Optional tool boxes and bed storage can accommodate any storage need for tools, work materials and more.

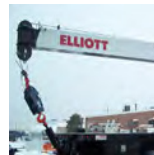

### Hook Block for Multi-Part Line

Elliott can install a 4 part hook block or a 7-8 part-hook block to improve lifting capabilities. The block can be stored at the rear of the bed.



### Gravity Levelled Basket

Elliott's pin-on work platform pins onto the boom for easy installation and removal. Gravity leveling and mechanical rotation makes it a great accessory for any worksite.

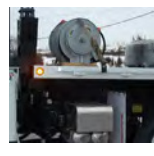

### Body Mounted Hose Reels and Circuits

Let us work with you to customize your tool compatability by adding hose reels or hydraulic circuits to the crane bed.

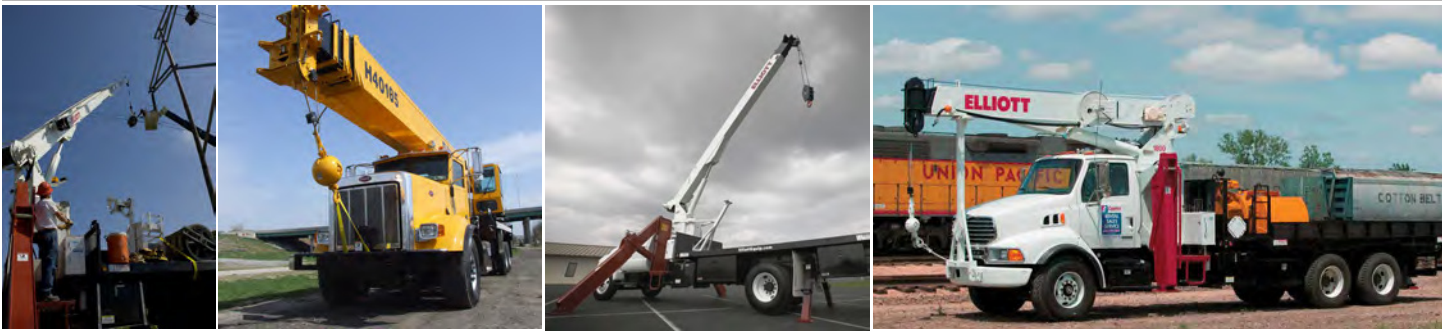

### 32117R SIDE VIEW DIAGRAM

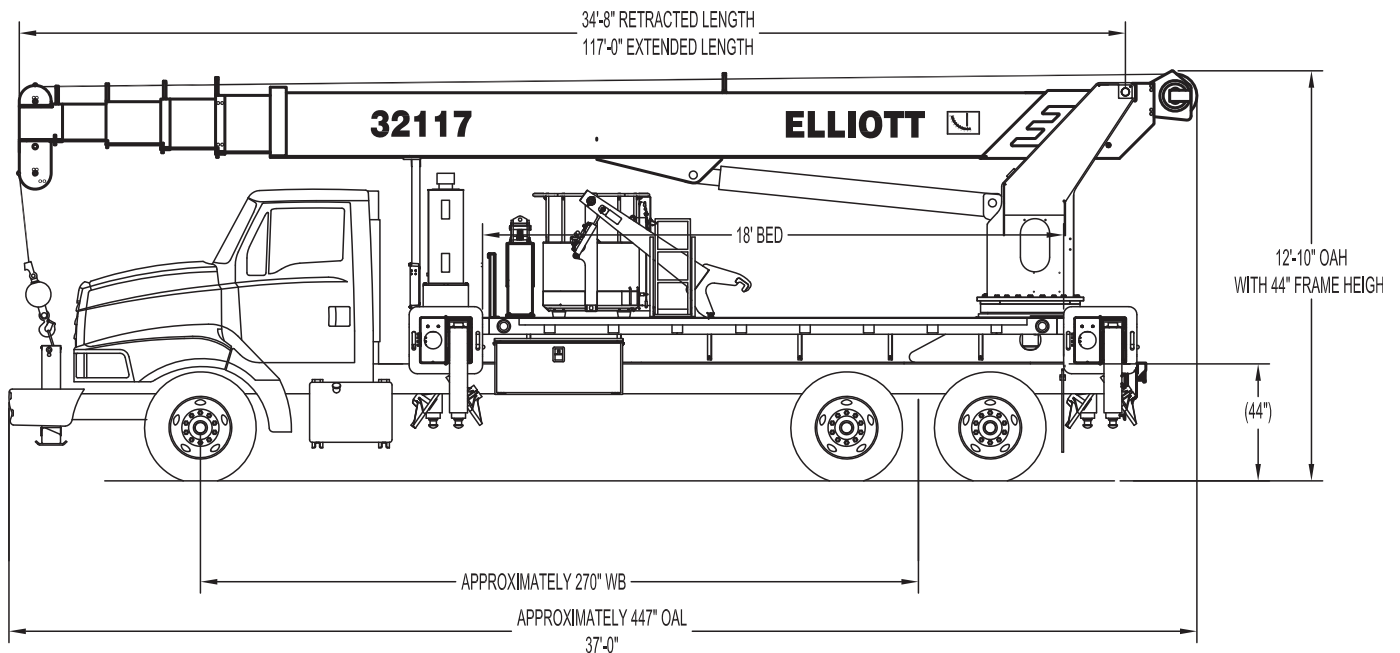

- |                                  |                                     |                                 |                              |
|----------------------------------|-------------------------------------|---------------------------------|------------------------------|
| • <b>Maximum Vertical Reach</b>  | 153' / 46,6 m                       | • <b>Powered Boom Sections</b>  | 5                            |
| • <b>Working Area</b>            | 180 Degrees Standard (360 Optional) | • <b>Overall Height</b>         | 12'10" / 3,9 m               |
| • <b>Lifting Capacity</b>        | 64,000 lbs / 29 030 kg              | • <b>Operator Controls</b>      | Single-Side Rotating Standup |
| • <b>Boom Length</b>             | 117' / 35,6 m                       | • <b>Outrigger Type Front</b>   | Out-Down                     |
| • <b>Crane Weight (Standard)</b> | 30,800 lbs / 13 971 kg              | • <b>Outrigger Spread Front</b> | 20'6" m                      |
| • <b>Jib Lengths</b>             | 24' / 7,3 m                         | • <b>Outrigger Type Rear</b>    | Out-Down                     |
| • <b>Winch Bare Drum Pull</b>    | 12,800 lbs / 5806 kg                | • <b>Outrigger Spread Rear</b>  | 20'6" m                      |

## TECHNICAL SPECIFICATIONS

**Crane Capacity:** 64,000 lbs at 5' load radius.

**Maximum Tip Height:** 129' height (153' with optional 24' jib)

**Control Console:** Rotating turret single operator standup control station equipped with four single axis control levers for the main crane controls. Operator station includes LMI display, bubble level gauge, engine start/stop switch, signal horn button, variable speed throttle switch, lifting capacity chart, range diagram chart, boom angle indicator, system pressure gauge, 12V DC power source, and cup holder. Independent ground level electric operated outrigger controls.

**Boom:** Five-section fully proportional, high strength steel plated rectangular tube sections. A maximum boom tip height of 129' mounted on a truck. The boom nose contains one floating upper sheave and three lower sheaves. Assembly includes heavy-duty cylinder fittings, pivot pins, and replaceable wear pads.

**Winch:** Mounted at the base of the boom for a long fleet angle and flat level spooling of cable. Winch is driven by a planetary reducer and powered by a hydraulic motor. Burst-of-speed winch provides increased line speed. The winch brake is spring applied, pressure release design. Supplied with 425' of 9/16" diameter rotation resistant wire rope with a single line pull of 9,060 pounds, and a downhaul ball with swivel hook for single part line.

**Load Moment Indicator System:**

System senses hoist cylinder pressures, boom length and boom angle with hydraulic function lockout. The display console is equipped with a bar graph showing crane utilization, boom angle or boom length, a mode select controls for main boom and jib operation, and an anti-two block with an audio/visual warning and shut-off functions to limit hook-boom point contact.

Elliott Equipment Company reserves the right to change the specification of any unit at any time without prior notice. This brochure is only a statement of general specifications on the date of this publication. For more detailed info on specific Elliott trucks go to [www.elliottequip.com](http://www.elliottequip.com)

**Outriggers:** Two sets of out and down overframe outriggers with 20' span. Outriggers are configured for full span or mid span operation. Outriggers equipped with ball socket aluminum removable pads that stow on vertical outrigger legs.

**Frame:** Full length, all welded rigid 4-plate design sub-frame. Sub-frame allows for bolt-on addition of 18' bed wings, with top plate of subbase serving as a portion of the bed deck, to form a three-piece bed.

**Turret:** Reverse offset turret is one-piece weldment. Turret rotates on large diameter ball bearing.

**Rotation:** Hydraulic motor drives turret through double reduction planetary swing drive for 372-degree non-continuous rotation.

**Lift:** One double-acting long stroke cylinder provides smooth and stable boom elevation. Holding valve prevents boom from falling in event of hose failure.

**Boom Extension:** Incorporates a 2-stage hydraulic extension cylinder, attached to the largest boom section, with a proportional cable extension system driving the outermost sections.

**Hoses:** All high pressure hoses are wire braid reinforced with a minimum safety factor of 4 to 1.

**Cylinders:** All cylinders use microhoned cylinder tubing, chrome shafts, top grade packing and protective rod wipers. Cylinder-mounted holding valves provided on all load-holding cylinders.

**Hydraulic System:** Equipped with air-shift PTO, piston pump, SAE O-ring face seals on pressure lines, and a 10-micron return line filter. The control valve distributes all flow to hoist system, swing circuit, and other crane functions. System is closed center type.

**Oil Tank Capacity:** 120 gallon mounted to truck frame on roadside.

**Cab Equipment:** PTO switch with indicator lights installed in truck cab. U/L approved 5:BC dry chemical fire extinguisher installed in truck cab.

**Operators Manual & Video:** Two CD copies and one hard copy of operation, maintenance, safety and parts manual provided with each unit. Operational and safety video provided at delivery.

**Installation:** Unit installed on chassis, painted, system and tank filled with oil, tested, inspected, and ready to operate.

**Standard Paint:** Paint turret and boom white, outriggers red, and bed and boxes black. Top of bed painted with black nonskid surface.

**Bumper:** Bureau of Motor Carrier Safety rear bumper.

**Weight:** Approximately 30,800 lbs. with 18' steel-floor bed less truck.

**Truck Chassis Required:** Approx. 204" C.A. RBM 3,300,000 in-lb. per rail, 20,000 lb. front axle and 60,000 lb. GVWR required. Trucks must have front frame extension, 12V electrical system with high capacity alternator, cab clearance stop/tail/backup lights, and I.D. lamps. Recommended GVWR is minimum for BoomTruck with flatbed only. Contact factory when additional equipment is to be added.

**Options:**

24' Fixed Jib.

Radio Remote Controls.

Gravity-Leveled and Rotating Steel Basket.

Tool Box Configurations.

Front Jack for 360 Degree Crane Operation.

Enclosed Control Cab with Heating and Air Conditioning.

Winch Drum Rotation Indicator.

Work Area Definition System (WADS).

Much More...

**LOAD CHART - MAIN BOOM, FULL-SPAN OUTRIGGERS**

DO NOT PAINT OVER ANY LABELS 1097740 101705



**MODEL 3200 117-ft BOOM**

**MAIN BOOM LOAD RATINGS WITH FULLY EXTENDED OUTRIGGERS**

**MAIN BOOM LOAD RATINGS**

**JIB LOAD RATINGS**

LOAD RATINGS IN lbs WITH OUTRIGGERS AND STABILIZERS EXTENDED

LOAD RATINGS IN lbs WITH OUTRIGGERS AND STABILIZERS EXTENDED

LOAD RADIUS IN FEET	LOADED BOOM ANGLE	28-ft	LOADED BOOM ANGLE	A	LOADED BOOM ANGLE	B	LOADED BOOM ANGLE	C	LOADED BOOM ANGLE	D	LOADED BOOM ANGLE	E	LOADED BOOM ANGLE	F
		42-ft		42-ft		57-ft		72-ft		87-ft		102-ft		117-ft
5	80	64,000												
6	78	54,000												
8	73.5	42,000												
10	69	35,000	76.5	28,000										
12	64	30,000	73.5	27,500	78.5	25,000								
14	59	26,500	70.5	25,000	76.5	23,600	80	20,000						
16	53.5	23,600	67.5	22,800	74.5	22,200	78.5	19,000						
18	47.5	20,000	64.5	20,400	72.5	20,600	77	18,200	80	16,100				
20	41	16,500	61	18,000	70	19,100	75	17,000	78	14,500				
25			52	14,000	64.5	14,300	71	14,000	75	13,000	78	11,800	79	7,200
30			42	10,000	58	10,950	66	11,000	71.5	11,200	75	10,200	77	7,200
35					52	8,650	62	8,800	68	8,850	72	8,900	75	7,200
40					45	7,000	57	7,100	64	7,200	69	7,250	72.5	7,200
45					36.5	5,600	52	5,800	60	5,900	65.5	5,950	69.5	6,000
50							46	4,750	56	4,850	62.5	4,900	67	4,950
55							40	3,900	55.5	4,000	59	4,000	64	4,100
60							32	2,800	47	3,200	55.5	3,250	61	3,250
65							22.5	2,400	42	2,600	51.5	2,750	58	2,750
70									36	2,000	47.5	2,150	54.5	2,150
75									29.5	1,400	43	1,600	51.5	1,650
80											38.5	1,000	47.5	1,200
85											33.5	800	44	800
90													40	500
0		8,500	0	4,700	0	2,600								

24-ft FIXED LENGTH JIB		
LOAD RADIUS IN FEET	LOADED BOOM ANGLE	24-ft JIB
30	79	4,000
35	77	3,900
40	75	3,750
45	73	3,450
50	71	3,050
55	68.5	2,650
60	66.5	2,350
65	64	2,050
70	62	1,850
75	59.5	1,650
80	57	1,450
85	54.5	1,150
90	51.5	800
95	48.5	500

**NOTICE**

- DO NOT DEADHEAD LINE BLOCK AGAINST BOOM TIP WHEN EXTENDING BOOM.
- KEEP AT LEAST 5 WRAPS OF LOADLINE ON THE WINCH DRUM AT ALL TIMES.
- USE ONLY 9/16" DIAMETER WIRE ROPE, AS SPECIFIED BELOW, WITH THE PROPER BREAKING STRENGTHS LISTED.
- ANTI-TWO-BLOCK SYSTEM MUST BE IN GOOD OPERATING CONDITION BEFORE OPERATING CRANE. SEE OPERATION & SAFETY MANUAL.

DEDUCTIONS FOR STOWED JIB (lbs)	550	350	300	250	200	150	100
---------------------------------	-----	-----	-----	-----	-----	-----	-----

DEDUCTIONS FOR STOWED FIXED LENGTH JIB (lbs)

1-PART LINE 	2-PART LINE 	3-PART LINE 	4-PART LINE 	5-PART LINE 	6-PART LINE 	7-PART LINE 
MAX PULL: 9,060 lbs	18,120 lbs	27,180 lbs	36,240 lbs	45,300 lbs	54,360 lbs	64,000 lbs

ELLIOTT EQUIPMENT CO. SUPPLIED LOADLINE EQUIPMENT DEDUCTIONS:  
 DOWNHAUL WEIGHT .....180 lbs  
 ONE SHEAVE BLOCK.....375 lbs  
 TWO SHEAVE BLOCK.....640 lbs  
 THREE SHEAVE BLOCK.....870 lbs  
 AUXILIARY SHEAVE.....100 lbs

9/16" - SPIN RESISTANT (5:1 S.F.)  
 45,300-lbs, BREAKING STRENGTH

CRANE MEETS ASME B30.5 REQUIREMENTS AT TIME OF MANUFACTURE



Elliott Equipment Company  
 3514 South 25th Street  
 Omaha, NE 68105  
 Phone: 402-592-4500  
 Fax: 402-592-4553  
 Email: sales@elliottequip.com

**Built for You.**  
 www.elliottequip.com

**LOAD CHART - MAIN BOOM, MID-SPAN OUTRIGGERS**



**MODEL 3200 117-ft BOOM**

**MAIN BOOM LOAD RATINGS WITH OUTRIGGERS AT MID-SPAN POSITION**

**MAIN BOOM LOAD RATINGS**

**JIB LOAD RATINGS**

LOAD RATINGS IN lbs WITH OUTRIGGERS AND STABILIZERS EXTENDED

LOAD RATINGS IN lbs WITH OUTRIGGERS AND STABILIZERS EXTENDED

LOAD RADIUS IN FEET	LOADED BOOM ANGLE	28-ft	LOADED BOOM ANGLE	A 42-ft	LOADED BOOM ANGLE	B 57-ft	LOADED BOOM ANGLE	C 72-ft	LOADED BOOM ANGLE	D 87-ft	LOADED BOOM ANGLE	E 102-ft	LOADED BOOM ANGLE	F 117-ft
5	80	64,000												
6	78	54,000												
8	73.5	42,000												
10	69	35,000	76.5	28,000										
12	64	30,000	73.5	27,500	78.5	25,000								
14	59	26,500	70.5	25,000	76.5	23,600	80	20,000						
16	53.5	21,700	67.5	22,500	74.5	22,200	78.5	19,000						
18	47.5	16,800	64.5	17,500	72.5	18,000	77	18,200	80	16,100				
20	41	13,500	61	14,000	70	14,500	75	14,800	78	14,500				
25			52	8,800	64.5	9,200	71	9,400	75	9,500	78	9,500	79	7,200
30			42	5,800	58	6,150	66	6,300	71.5	6,400	75	6,450	77	6,500
35					52	4,200	62	4,350	68	4,450	72	4,500	75	4,550
40					45	2,850	57	3,000	64	3,100	69	3,150	72.5	3,150
45					36.5	1,800	52	2,000	60	2,100	65.5	2,100	69.5	2,150
50							46	1,200	56	1,300	62.5	1,350	67	1,350
	0	5,000	0	2,000										

24-ft FIXED LENGTH JIB		
LOAD RADIUS IN FEET	LOADED BOOM ANGLE	24-ft JIB
30	79	4,000
35	77	3,900
40	75	2,850
45	73	1,850
50	71	1,100
55	68.5	500

**NOTICE**

- DO NOT DEADHEAD LINE BLOCK AGAINST BOOM TIP WHEN EXTENDING BOOM.
- KEEP AT LEAST 5 WRAPS OF LOADLINE ON THE WINCH DRUM AT ALL TIMES.
- USE ONLY 9/16" DIAMETER WIRE ROPE, AS SPECIFIED BELOW, WITH THE PROPER BREAKING STRENGTHS LISTED.
- ANTI-TWO-BLOCK SYSTEM MUST BE IN GOOD OPERATING CONDITION BEFORE OPERATING CRANE. SEE OPERATION & SAFETY MANUAL.

DEDUCTIONS FOR STOWED JIB (lbs)	550	350	300	250	200	150	100
---------------------------------	-----	-----	-----	-----	-----	-----	-----

DEDUCTIONS FOR STOWED FIXED LENGTH JIB (lbs)

1-PART LINE	2-PART LINE	3-PART LINE	4-PART LINE	5-PART LINE	6-PART LINE	7-PART LINE
MAX PULL: 9,060 lbs	18,120 lbs	27,180 lbs	36,240 lbs	45,300 lbs	54,360 lbs	64,000 lbs

ELLIOTT EQUIPMENT CO. SUPPLIED LOADLINE EQUIPMENT DEDUCTIONS:  
 DOWNHAUL WEIGHT .....180 lbs  
 ONE SHEAVE BLOCK.....375 lbs  
 TWO SHEAVE BLOCK.....640 lbs  
 THREE SHEAVE BLOCK.....870 lbs  
 AUXILIARY SHEAVE.....100 lbs

9/16" - SPIN RESISTANT (6:1 S.F.)  
 45,300-lbs. BREAKING STRENGTH

CRANE MEETS ASME B30.5 REQUIREMENTS AT TIME OF MANUFACTURE

DO NOT PAINT OVER ANY LABELS 1097740 101705



Elliott Equipment Company  
 3514 South 25th Street  
 Omaha, NE 68105  
 Phone: 402-592-4500  
 Fax: 402-592-4553  
 Email: sales@elliottequip.com

**Built for You.**  
[www.elliottequip.com](http://www.elliottequip.com)

**RANGE CHART - MAIN BOOM + JIB, FULL-SPAN OUTRIGGERS**



**MODEL 3200**

**117-ft BOOM**

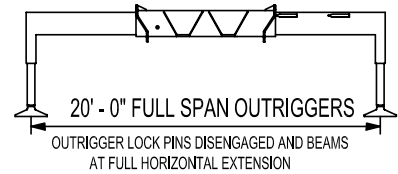
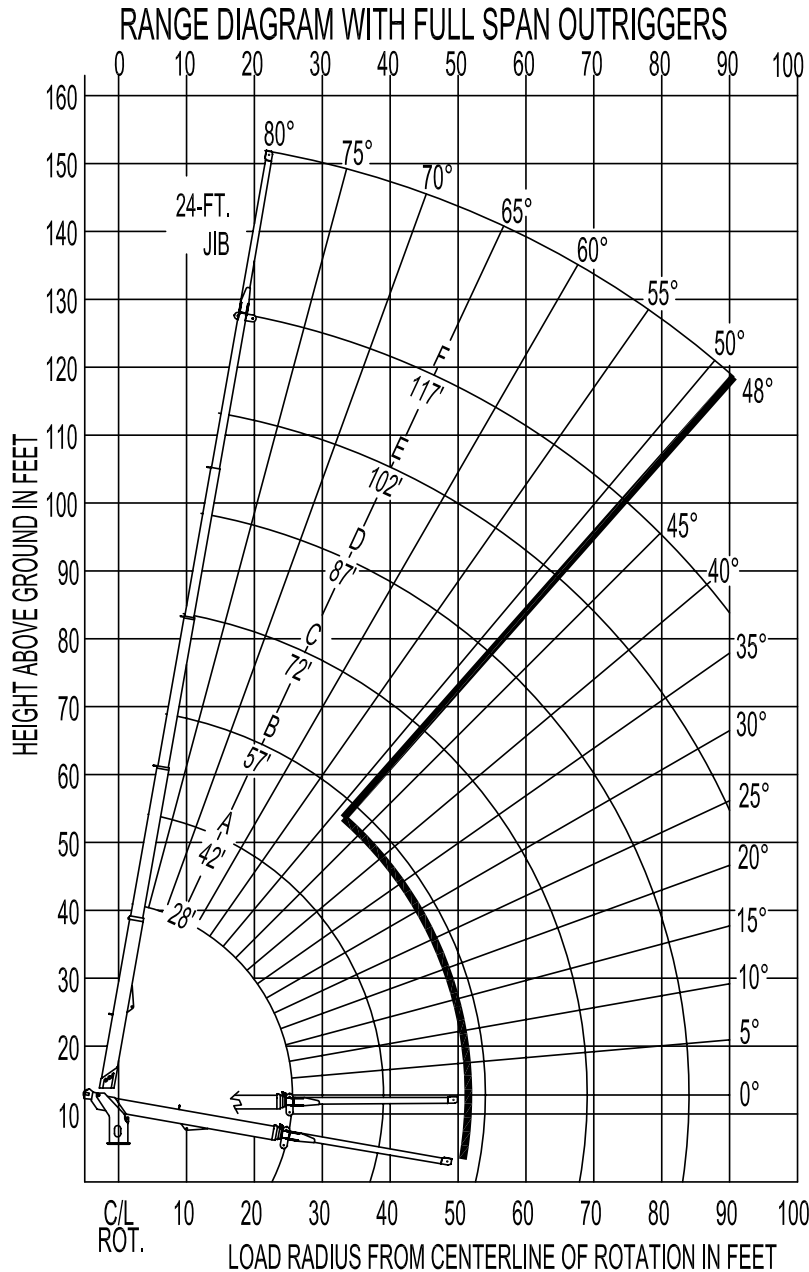

**NOTE:**

1. Operate jib by radius when main boom is fully extended. Increase boom angle if necessary to maintain load radius.
2. When boom is retracted, operate jib by boom angle. Do not exceed any rated jib capacities at reduced boom lengths.
3. Capacities do not exceed 85% stability.
4. Load ratings above bold line are structurally limited.
5. Personnel handling is allowed only with full span outriggers.
6. Boom load ratings are based on loaded boom radius. Loaded boom angles are given as reference only.

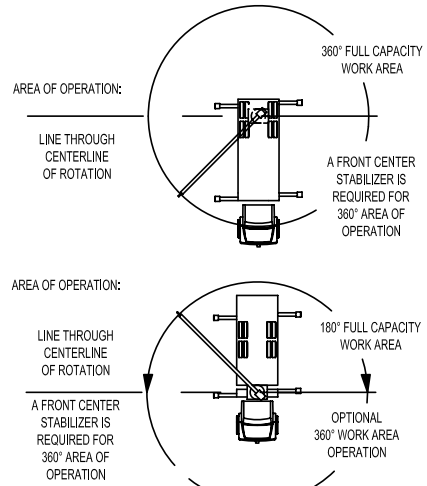

DO NOT PAINT OVER ANY LABELS 1097740 101705

**LOAD CHART - MAIN BOOM + JIB, MID-SPAN OUTRIGGERS**



**MODEL 3200 117-ft BOOM**

**RANGE DIAGRAM WITH MID-SPAN OUTRIGGERS**

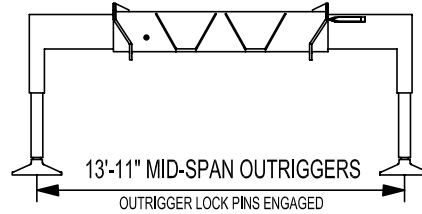
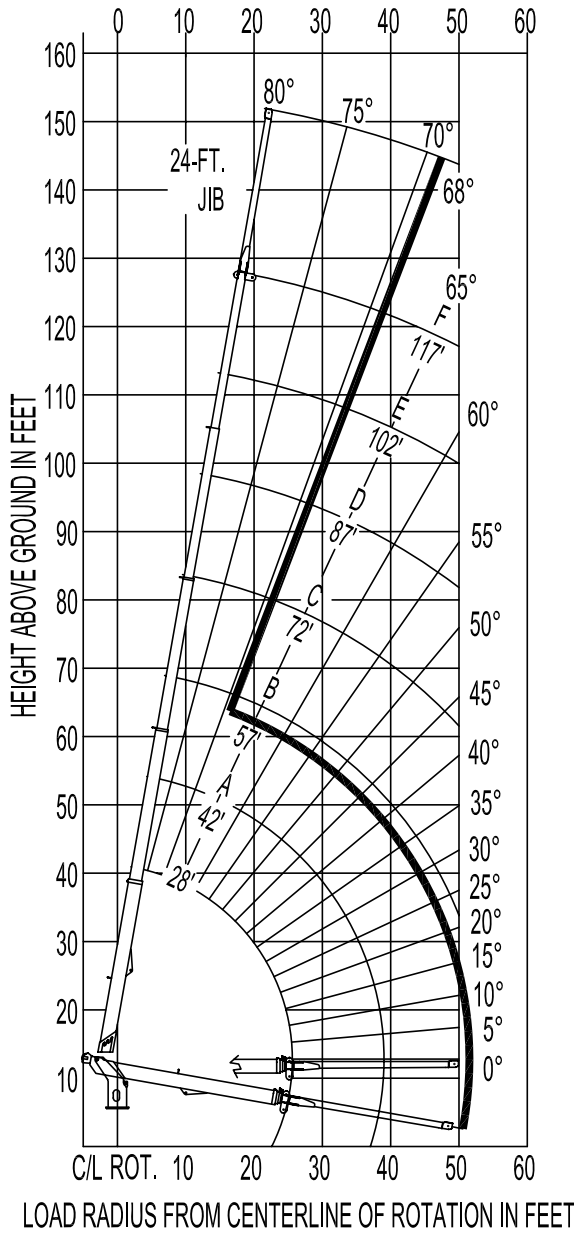

**NOTE:**

1. Operate jib by radius when main boom is full extended. Increase boom angle if necessary to maintain load radius.
2. When boom is retracted, operate jib by boom angles. Do not exceed any rated jib capacities at reduced boom lengths.
3. Capacities do not exceed 85% stability.
4. Load ratings above bold line are structurally limited.
5. Personnel handling is allowed only with full span outriggers.
6. Boom load ratings are based on loaded boom radius. Loaded boom angles are given as reference only.

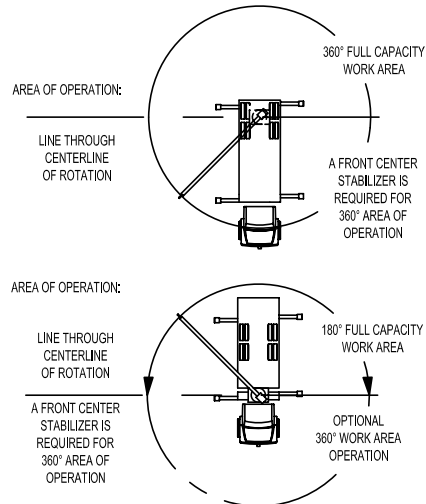

DO NOT PAINT OVER ANY LABELS

1097740 101705



Elliott Equipment Company  
 3514 South 25th Street  
 Omaha, NE 68105  
 Phone: 402-592-4500  
 Fax: 402-592-4553  
 Email: sales@elliottequip.com

**Built for You.**  
[www.elliottequip.com](http://www.elliottequip.com)

## TRUCK CHASSIS SPECIFICATIONS

	32117R BoomTruck
Wheelbase (WB)	256" / 650 cm
Cab to Trunnion CT)	192" / 487 cm
Cab to End of Frame (EOF)	286" / 726 cm
Frame Section Modulus	30.0 in3-110,000 psi / 492 cm3-758,428 kPa
Front Axle Gross Weight Rating	20,000 lb / 9071 kg
Rear Axle Gross Weight Rating	40,000 lb / 18 143 kg
Integral Front Frame Rails	Required for Front Stabilizer

Chassis data is minimum general requirements-not for engineering.  
 Actual dimensions and truck data will depend on truck selection and axle configuration.  
 \*Minimum chassis weight is required to meet 85% stability requirements.

## OPTIONS



### Radio Remote Control

Interference protected radio remotes let you get closer to your work and have full control over your machine.



### Pin-On Jib Attachment

One piece fixed jib that stow on the side of the boom for easy placement while on the worksite.

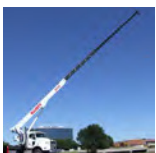

### 360 Degree Area of Operation

Add the convenience of 360 degree area of operation by adding a front stabilizer for increased flexibility on the jobsite.



### Hydraulic Oil Cooler

Add a bed-mounted hydraulic oil cooler and fan to assist with high duty cycle job applications. A "must" for hot weather environments



### Operator Cab

The enclosed crane operator cab includes windshield wipers, intuitive control systems, and optional heating and air conditioning.

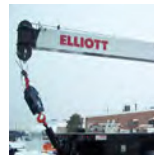

### Hook Block for Multi-Part Line

Elliott can install a range of hook blocks to improve lifting capabilities. The blocks can be stored at the rear of the bed in a special holder



### Gravity Levelled Work Platform

Elliott's pin-on work platform pins onto the boom for easy installation and removal. Gravity leveling and hydraulic yoke makes it a great accessory for multiple applications.

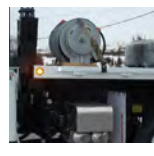

### Body Mounted Hose Reels and Circuits

Let us work with you to customize your tool compatability by adding hose reels or hydraulic circuits to the crane bed.

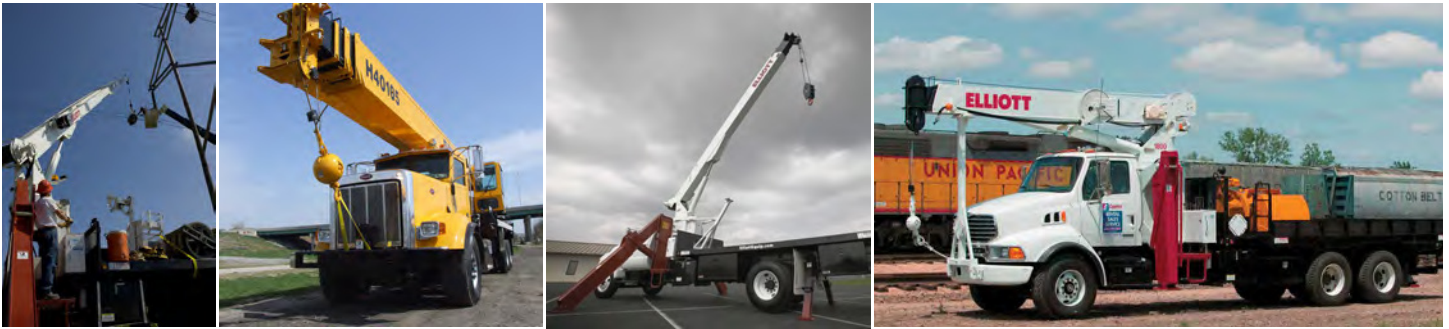

### 34127R SIDE VIEW DIAGRAM

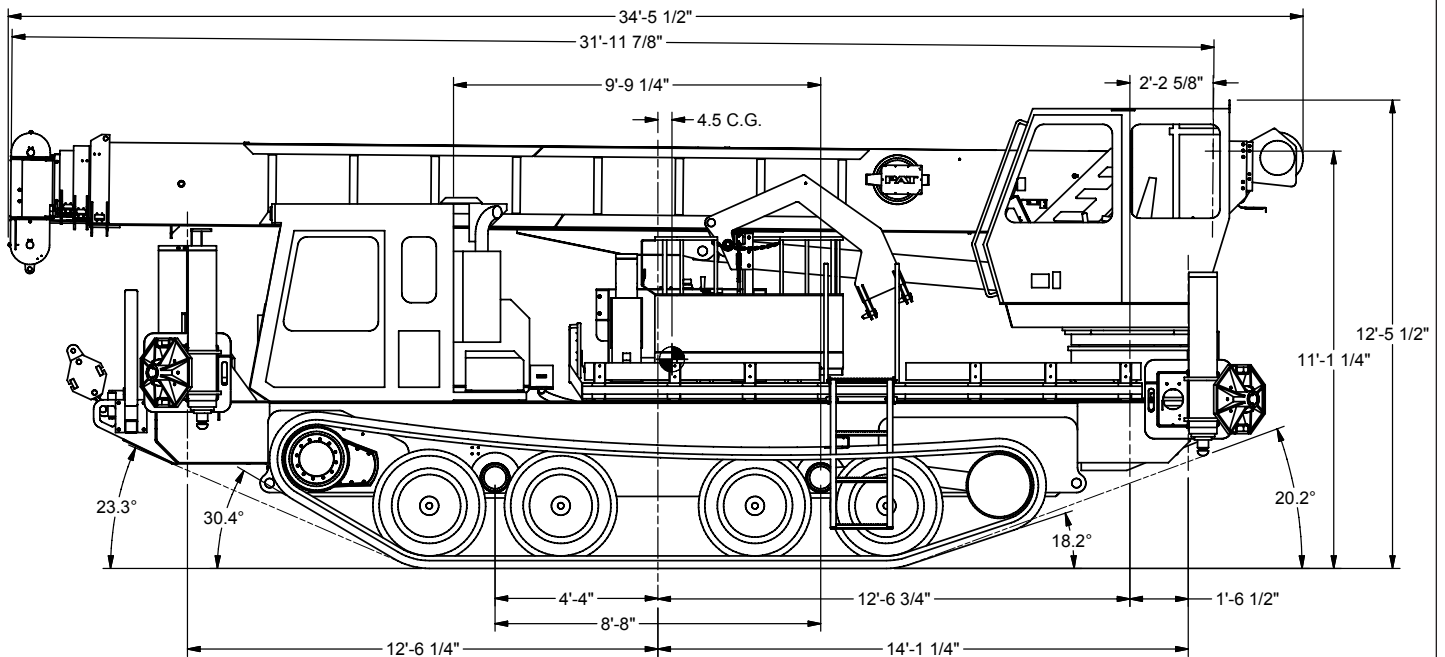

- |                                  |                      |                                 |                             |
|----------------------------------|----------------------|---------------------------------|-----------------------------|
| • <b>Maximum Vertical Reach</b>  | 186'/57 m            | • <b>Powered Boom Sections</b>  | 5                           |
| • <b>Working Area</b>            | 360 Degrees          | • <b>Overall Height</b>         | 12'6\"/>                    |
| • <b>Lifting Capacity</b>        | 68,000 lbs/30 844 kg | • <b>Operator Controls</b>      | Rotating Seated Crane Cabin |
| • <b>Boom Length</b>             | 127'/39m             | • <b>Outrigger Type Front</b>   | Out-Down                    |
| • <b>Crane Weight (Standard)</b> | 35,300 lbs/16 012 kg | • <b>Outrigger Spread Front</b> | 22'4\"/>                    |
| • <b>Jib Lengths</b>             | 49'/15 m             | • <b>Outrigger Type Rear</b>    | Out-Down                    |
| • <b>Winch Bare Drum Pull</b>    | 12,800 lbs/5806 kg   | • <b>Outrigger Spread Rear</b>  | 22'4\"/>                    |

## TECHNICAL SPECIFICATIONS

**Crane Capacity:** 68,000 lbs at 6' load radius.

**Maximum Tip Height:** 137' height (186' with optional 49' jib)

**Control Console:** Rotating open seated controls with deluxe operator seat, electric control levers in seat console, pressure gauge, LMI display, bubble level gauge, engine start/stop switch, signal horn button, variable speed throttle switch, lifting capacity chart, range diagram chart, boom angle indicator, system pressure gauge, 12V DC power source, and cup holder. Independent ground level electric operated outrigger controls.

**Boom:** Five-section fully proportional, high strength steel plated rectangular tube sections. A maximum boom tip height of 137'. The boom nose contains one floating upper sheave and three lower sheaves. Assembly includes heavy-duty cylinder fittings, pivot pins, and replaceable wear pads.

**Winch:** Mounted at the base of the boom for a long fleet angle and flat level spooling of cable. Winch is driven by a planetary reducer and powered by a hydraulic motor. Burst-of-speed winch provides increased line speed. The winch brake is spring applied, pressure release design. Supplied with 425' of 9/16" diameter rotation resistant wire rope with a single line pull of 9,060 pounds, and a downhaul ball with swivel hook for single part line.

**Load Moment Indicator System:**

System senses hoist cylinder pressures, boom length and boom angle with hydraulic function lockout. The display console is equipped with a bar graph showing crane utilization, boom angle or boom length, a mode select controls for main boom and jib operation, and an anti-two block with an audio/visual warning and shut-off functions to limit hook-boom point contact.

**Outriggers:** Two sets of two stage extended out and down overframe outriggers with 22'4" span. Outriggers are configured for full span operation. Outriggers equipped with ball socket aluminum removable pads that stow on vertical outrigger legs.

**Frame:** 4-plate design sub-frame inside track tub. Sub-frame allows for bolt-on addition of steel diamond plated bed with stake pockets.

**Turret:** Reverse offset turret is one-piece weldment. Turret rotates on large diameter ball bearing.

**Rotation:** Hydraulic motor drives turret through double reduction planetary swing drive for continuous rotation. The swing drive system has a spring applied, pressure release brake.

**Lift:** One double-acting long stroke cylinder provides smooth and stable boom elevation. Holding valve prevents boom from falling in event of hose failure.

**Boom Extension:** Incorporates a 2-stage hydraulic extension cylinder, attached to the largest boom section, with a proportional cable extension system driving the outermost sections.

**Hoses:** All high pressure hoses are wire braid reinforced with a minimum safety factor of 4 to 1.

**Cylinders:** All cylinders use microhoned cylinder tubing, chrome shafts, top grade packing and protective rod wipers. Cylinder-mounted holding valves provided on all load-holding cylinders.

**Hydraulic System:** Equipped with piston pump, SAE O-ring face seals on pressure lines, and a 10-micron return line filter. The control valve distributes all flow to hoist system, swing circuit, and other crane functions. System is closed center type.

**Oil Tank Capacity:** 120 gallon mounted on top of bed.

**Cab Equipment:** U/L approved 5:BC dry chemical fire extinguisher installed in truck cab.

**Operators Manual & Video:** Two CD copies and one hard copy of operation, maintenance, safety and parts manual provided with each unit. Operational and safety video provided at delivery.

**Installation:** Unit installed on track vehicle, painted, system and tank filled with oil, tested, inspected, and ready to operate.

**Standard Paint:** Paint turret and boom white, outriggers red, and bed and boxes black.

**Weight:** Approximately 35,300 lbs. (crane only).

**Track Vehicle Required:** 42,000 lb capacity, 12V electrical system with high capacity alternator. Contact factory for complete specification review.

**Options:**

Rotating Seated Controls with Enclosed Operator Cab

Air Conditioning for Crane Cab

32-49' Telescopic Jib for Basket

Two-Person Gravity-Levelled Basket

Radio Remote Controls

Front Brush Guard

Front or Rear Recovery Winch

Much More...

Elliott Equipment Company reserves the right to change the specification of any unit at any time without prior notice. This brochure is only a statement of general specifications on the date of this publication. For more detailed info on specific Elliott trucks go to [www.elliottequip.com](http://www.elliottequip.com)

**LOAD CHART - MAIN BOOM, FULL-SPAN OUTRIGGERS**









**LOAD RATINGS WITH FULLY EXTENDED OUTRIGGERS**

**MAIN BOOM LOAD RATINGS (lbs)**

LOAD RADJUS IN FEET	LOADED BOOM ANGLE	32-ft	LOADED BOOM ANGLE	A 52-ft	LOADED BOOM ANGLE	B 70-ft	LOADED BOOM ANGLE	C 90-ft	LOADED BOOM ANGLE	D 110-ft	LOADED BOOM ANGLE	E 127-ft		
6	75.0	68,000												
8	71.3	48,000												
10	67.5	41,000	74.2	33,000										
12	63.5	35,900	71.5	30,000										
15	57.4	28,000	67.4	26,000	75.7	22,600								
20	45.9	20,000	60.4	19,000	71.5	19,000	77.0	16,600						
25	31.6	15,000	52.7	14,300	67.1	15,400	73.5	14,200	78.0	12,300	81.0	8,300		
30			44.2	10,800	62.6	12,000	70.0	11,900	75.2	10,600	78.5	8,000		
35			34.1	8,600	57.8	9,700	66.0	9,700	72.0	9,100	76.0	7,800		
40			20.1	6,800	52.9	7,900	62.0	8,000	69.0	7,900	73.5	7,500		
45					47.5	6,400	58.3	6,500	66.0	6,600	71.0	6,700		
50					41.7	5,100	54.5	5,300	62.5	5,400	68.0	5,600		
55					35.1	4,000	50.5	4,200	59.5	4,300	65.5	4,700		
60					27.2	3,200	46.2	3,300	56.0	3,400	63.0	3,800		
65					16.1	2,400	41.6	2,600	52.3	2,700	60.5	3,000		
70							36.6	2,000	48.9	2,100	57.0	2,300		
75							30.9	1,500	45.4	1,600	54.5	1,800		
80							23.9	1,000	41.6	1,100	51.4	1,300		
85							14.2	700	37.5	800	47.4	900		
90											44.3	500		
	0	10,000	0	4,100	0	2,000								
DEDUCTIONS FOR STOWED JIB (lbs)		900		560		410		320		260		230		

ELLIOTT EQUIPMENT CO. SUPPLIED  
LOADLINE EQUIPMENT DEDUCTIONS:  
 DOWNHAUL WEIGHT .....180 lbs  
 ONE SHEAVE BLOCK.....236 lbs  
 TWO SHEAVE BLOCK.....291 lbs  
 THREE SHEAVE BLOCK.....639 lbs  
 FOUR SHEAVE BLOCK.....762 lbs  
 AUXILIARY SHEAVE.....100 lbs

DEDUCTIONS FOR STOWED EXTENDABLE JIB (lbs)

1-PART LINE	2-PART LINE	3-PART LINE	4-PART LINE	5-PART LINE	6-PART LINE	7-PART LINE	8-PART LINE	NOTICE
								- DO NOT DEADHEAD LINE BLOCK AGAINST BOOM TIP WHEN EXTENDING BOOM. - KEEP AT LEAST 5 WRAPS OF LOADLINE ON THE WINCH DRUM AT ALL TIMES. - USE ONLY 9/16" DIAMETER WIRE ROPE, AS SPECIFIED BELOW, WITH THE PROPER BREAKING STRENGTHS LISTED. - ANTI-TWO-BLOCK SYSTEM MUST BE IN GOOD OPERATING CONDITION BEFORE OPERATING CRANE. SEE OPERATION & SAFETY MANUAL.
MAX PULL: 9,600 lbs	19,200 lbs	28,800 lbs	38,400 lbs	48,000 lbs	57,600 lbs	67,200 lbs	68,000 lbs	9/16" - 6 x 37 IWRC (3.51 S.F.) 33,600-lbs. BREAKING STRENGTH
MAX PULL: 9,060 lbs	18,120 lbs	27,180 lbs	36,240 lbs	45,300 lbs	54,360 lbs	63,420 lbs	68,000 lbs	9/16" - SPIN RESISTANT (5:1 S.F.) 45,300-lbs. BREAKING STRENGTH

**RANGE CHART - MAIN BOOM, FULL-SPAN OUTRIGGERS**

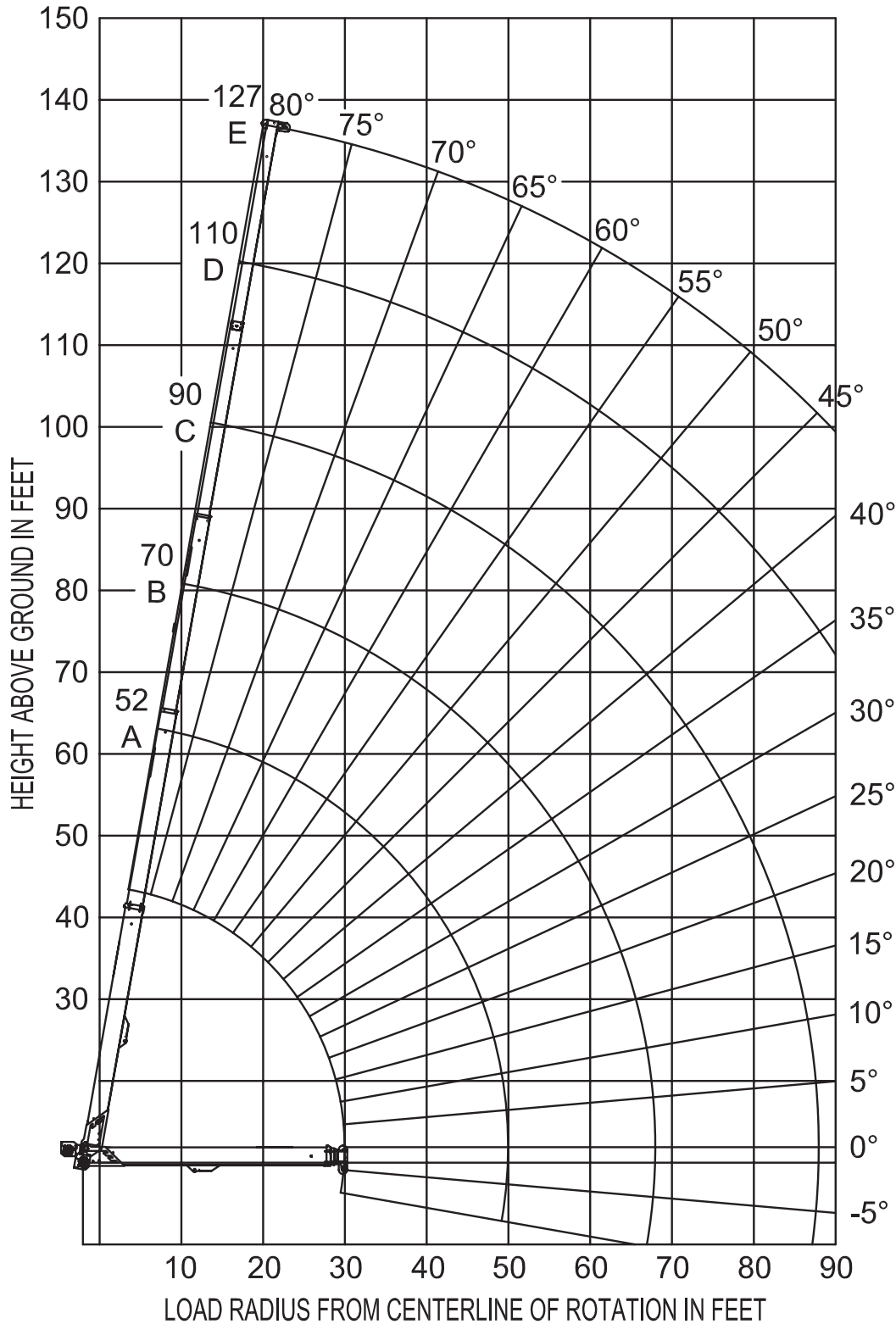

**RANGE CHART - JIB + WORK PLATFORM, FULL-SPAN OUTRIGGERS**

RANGE DIAGRAM WITH PLATFORM ATTACHED AND 32 / 49 FT PLATFORM EXTENSION

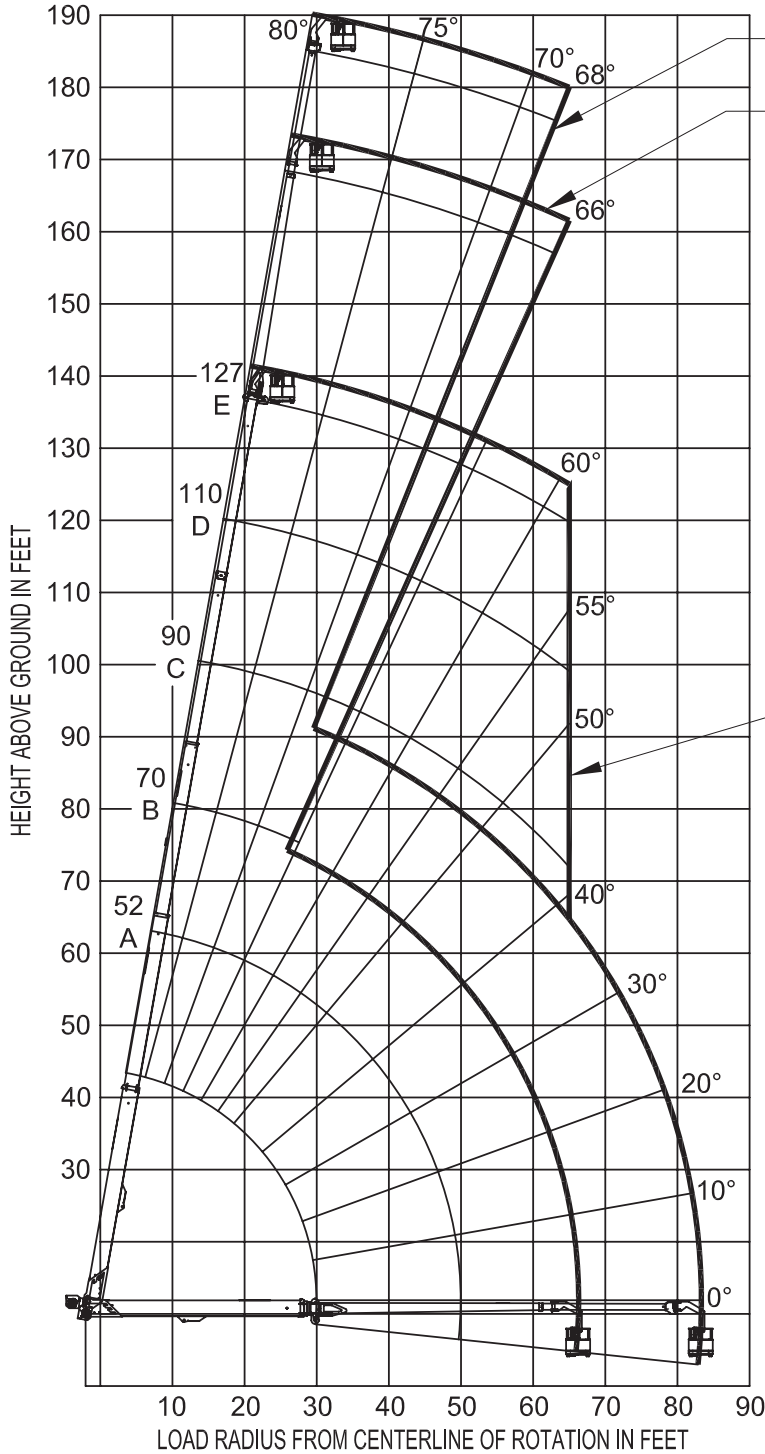

PLATFORM EXTENSION OUT (49')

PLATFORM EXTENSION IN (32')

**PERSONNEL HANDLING IS ALLOWED ONLY WITH FULL SPAN OUTRIGGERS**

**PLATFORM CAPACITY 600 LB**

**DO NOT OPERATE PLATFORM EXTENSION IN WINDS EXCEEDING 15 MPH**

PLATFORM ON MAIN BOOM

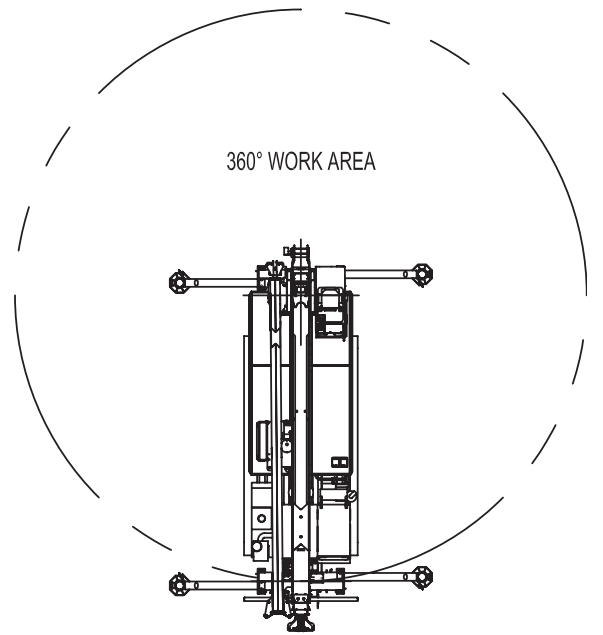

## TRACK VEHICLE SPECIFICATIONS

	34127R BoomTruck
Overall Length	330" / 838 cm
Overall Width	204" / 518 cm
Overall Height	334" / 848 cm
Payload Capacity	42,000 lbs / 19,051 kg
Electrical System	12 Volt
Drive System	Hydrostatic

Chassis data is minimum general requirements-not for engineering.  
 Actual dimensions and track vehicle data will depend on machine selection and configuration.  
 \*Minimum chassis weight is required to meet 85% stability requirements.

## OPTIONS



### Radio Remote Control

Interference protected radio remotes let you get closer to your work and have full control over your machine. Includes battery charging feature and optional LMI screen.

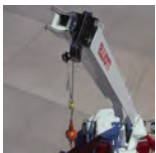

### Pin-On Jib Attachment

One piece & two piece telescoping or fixed jibs that stow on the side of the boom for easy placement while on the worksite.



### Brush Guard

Heavy-duty steel brush guard prevents tree limbs and other materials from damaging the BoomTruck or obscuring visibility.



### High-Power Recovery Winch

A front or rear mounted recovery winch makes it easy to pull equipment out of thick mud and rough terrain.



### Operator Cab

The enclosed crane operator cab includes windshield wipers, intuitive control systems, and optional heating and air conditioning.



### Hook Block for Multi-Part Line

Elliott can install a 2-3 part hook block or a 4 part-hook block to improve lifting capabilities. The block can store right on the rear of the bed.



### Gravity Levelled Basket

Elliott's work platform pins onto the boom for easy installation and removal. Gravity leveling and mechanical rotation makes it a great accessory for any worksite.

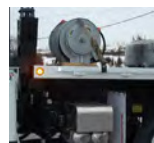

### Body Mounted Hose Reels and Circuits

Let us work with you to customize your tool compatibility by adding hose reels or hydraulic circuits to the crane bed.

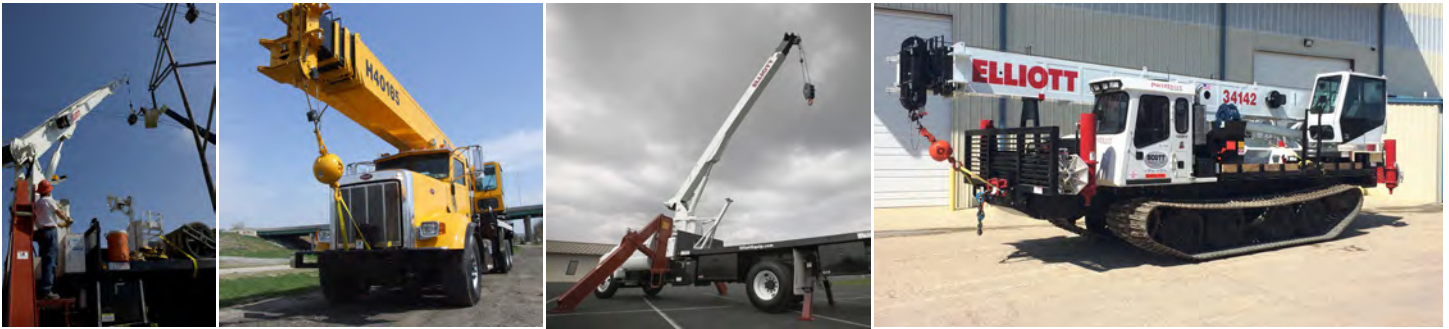

### 34142 SIDE VIEW DIAGRAM

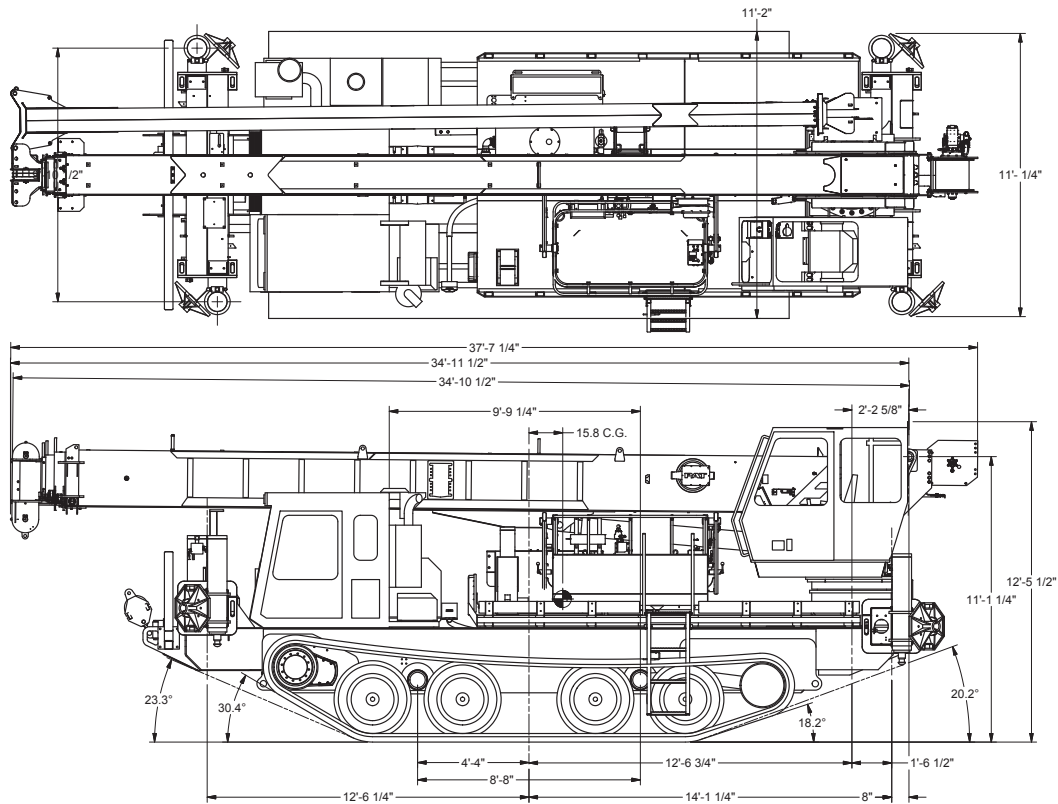

- |                                  |                      |                                 |                           |
|----------------------------------|----------------------|---------------------------------|---------------------------|
| • <b>Maximum Vertical Reach</b>  | 201'61,3 m           | • <b>Powered Boom Sections</b>  | 5                         |
| • <b>Working Area</b>            | 360 Degrees          | • <b>Overall Height</b>         | 12'6"/3,8 m               |
| • <b>Lifting Capacity</b>        | 68,000 lbs/30 844 kg | • <b>Operator Controls</b>      | Rotating Seated Crane Cab |
| • <b>Boom Length</b>             | 142'43,3 m           | • <b>Outrigger Type Front</b>   | Out-Down                  |
| • <b>Crane Weight (Standard)</b> | 38,600 lbs/17 508 kg | • <b>Outrigger Spread Front</b> | 22'4"/6,8 m               |
| • <b>Jib Lengths</b>             | 32'-49'9,7-15 m      | • <b>Outrigger Type Rear</b>    | Out-Down                  |
| • <b>Winch Bare Drum Pull</b>    | 12,800 lbs/5806 kg   | • <b>Outrigger Spread Rear</b>  | 22'4"/6,8 m               |

## TECHNICAL SPECIFICATIONS

**Crane Capacity:** 68,000 lbs at 6' load radius.

**Maximum Tip Height:** 152' height (201' with optional 32'-49' jib)

**Control Console:** Rotating open seated controls with deluxe operator seat, electric control levers in seat console, pressure gauge, LMI display, bubble level gauge, engine start/stop switch, signal horn button, variable speed throttle switch, lifting capacity chart, range diagram chart, boom angle indicator, system pressure gauge, 12V DC power source, and cup holder. Independent ground level electric operated outrigger controls.

**Boom:** Five-section fully proportional, high strength steel plated rectangular tube sections. A maximum boom tip height of 152'. The boom nose contains one floating upper sheave and three lower sheaves. Assembly includes heavy-duty cylinder fittings, pivot pins, and replaceable wear pads.

**Winch:** Mounted at the base of the boom for a long fleet angle and flat level spooling of cable. Winch is driven by a planetary reducer and powered by a hydraulic motor. Burst-of-speed winch provides increased line speed. The winch brake is spring applied, pressure release design. Supplied with 425' of 9/16" diameter rotation resistant wire rope with a single line pull of 9,060 pounds, and a downhaul ball with swivel hook for single part line.

**Load Moment Indicator System:**

System senses hoist cylinder pressures, boom length and boom angle with hydraulic function lockout. The display console is equipped with a bar graph showing crane utilization, boom angle or boom length, a mode select controls for main boom and jib operation, and an anti-two block with an audio/visual warning and shut-off functions to limit hook-boom point contact.

**Outriggers:** Two sets of two-stage extended out and down overframe outriggers with 22'4" span. Outriggers are configured for full span operation. Outriggers equipped with ball socket aluminum removable pads that stow on vertical outrigger legs.

**Frame:** 4-plate design sub-frame inside track tub. Sub-frame allows for bolt-on addition of steel diamond plated bed with stake pockets.

**Turret:** Reverse offset turret is one-piece weldment. Turret rotates on large diameter ball bearing.

**Rotation:** Hydraulic motor drives turret through double reduction planetary swing drive for continuous rotation. The swing drive system has a spring applied, pressure release brake.

**Lift:** One double-acting long stroke cylinder provides smooth and stable boom elevation. Holding valve prevents boom from falling in event of hose failure.

**Boom Extension:** Incorporates a 2-stage hydraulic extension cylinder, attached to the largest boom section, with a proportional cable extension system driving the outermost sections.

**Hoses:** All high pressure hoses are wire braid reinforced with a minimum safety factor of 4 to 1.

**Cylinders:** All cylinders use microhoned cylinder tubing, chrome shafts, top grade packing and protective rod wipers. Cylinder-mounted holding valves provided on all load-holding cylinders.

**Hydraulic System:** Equipped with piston pump, SAE O-ring face seals on pressure lines, and a 10-micron return line filter. The control valve distributes all flow to hoist system, swing circuit, and other crane functions. System is closed center type.

**Oil Tank Capacity:** 120 gallon mounted on top of bed.

**Cab Equipment:** U/L approved 5:BC dry chemical fire extinguisher installed in truck cab.

**Operators Manual & Video:** Two CD copies and one hard copy of operation, maintenance, safety and parts manual provided with each unit. Operational and safety video provided at delivery.

**Installation:** Unit installed on track vehicle, painted, system and tank filled with oil, tested, inspected, and ready to operate.

**Standard Paint:** Paint turret and boom white, outriggers red, and bed and boxes black.

**Weight:** Approximately 38,600 lbs.

**Track Vehicle Required:** 40,000 lb payload capacity, 12V electrical system with high capacity alternator. Contact factory for complete specification review.

**Options:**

Rotating Seated Controls with Enclosed Operator Cab

Air Conditioning for Crane Cab

32'-49' Telescopic Jib for Workplatform

Two-Person Hydraulic Dampening Yoke Workplatform

Radio Remote Controls

Front Brush Guard

Front or Rear Recovery Winch

Much More...

Elliott Equipment Company reserves the right to change the specification of any unit at any time without prior notice. This brochure is only a statement of general specifications on the date of this publication. For more detailed info on specific Elliott trucks go to [www.elliottequip.com](http://www.elliottequip.com)

**LOAD CHART - MAIN BOOM, FULL-SPAN OUTRIGGERS**



**MODEL 3400 142-ft BOOM**

LOAD RATINGS WITH FULLY EXTENDED OUTRIGGERS

**MAIN BOOM LOAD RATINGS (lbs)**

LOAD RADIUS IN FEET	LOADED BOOM ANGLE	35-ft	LOADED BOOM ANGLE	A	LOADED BOOM ANGLE	B	LOADED BOOM ANGLE	C	LOADED BOOM ANGLE	D	LOADED BOOM ANGLE	E	LOADED BOOM ANGLE	F	LOADED BOOM ANGLE	G	LOADED BOOM ANGLE	H
		47-ft		61-ft		74-ft		88-ft		101-ft		115-ft		128-ft		142-ft		
6	81.1	68,000																
8	77.7	48,000																
10	74.2	41,000	78.4	38,000														
12	70.6	35,900	75.9	33,000	79.1	30,000												
15	65	28,000	71.9	26,300	76.3	24,300	79.5	24,000										
20	54.9	20,000	65.1	19,500	71.4	19,000	75.7	17,300	78.7	16,600								
25	43	15,000	57.8	15,000	66.3	14,850	71.5	14,500	75.2	14,200	77.8	13,000	81	11,000				
30	26.3	11,000	49.8	11,800	60.6	11,400	67.2	11,900	71.7	11,900	75	11,100	77.5	9,800	79.3	8,000		
35			40.5	9,000	54.5	9,150	62.8	9,700	68.1	9,700	72	9,300	75	8,700	77	7,800	79.1	6,000
40			28.6	6,800	48	7,400	58	8,000	64.4	8,000	68.8	7,900	72.2	7,700	74.9	7,500	77	5,600
45					40.7	6,000	52.9	6,400	60.6	6,500	65.6	6,500	69.8	6,600	72.6	6,500	74.8	5,400
50					31.9	4,700	47.3	5,200	56.5	5,300	62.3	5,300	67	5,400	70.1	5,400	72.7	5,000
55					19.8	3,600	41.2	4,100	52.3	4,200	59.1	4,200	64.2	4,400	67.6	4,400	70.5	4,400
60							34.9	3,200	48	3,300	55.5	3,300	61.2	3,500	65	3,500	68.3	3,500
65							26.4	2,500	43	2,600	51.8	2,600	58.1	2,700	62.4	2,900	65.9	2,900
70							12.9	1,300	37.3	2,000	47.6	2,000	55	2,100	59.7	2,100	63.6	2,100
75									30.8	1,400	43.1	1,500	54.6	1,600	56.9	1,600	61.2	1,600
80									22.5	800	38.2	1,000	47.8	1,100	54	1,100	58.7	1,100
85											32.7	500	43.8	500	50.8	600	56.2	600
	0	10,000	0	6,000	0	3,000	0	1,000										
DEDUCTIONS FOR STOWED PLATFORM EXTENSION		900		650		500		400		350		300		250		250		200

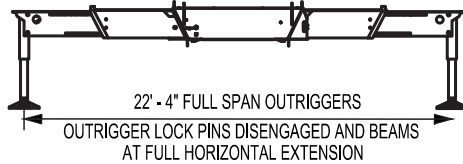

ELLIOTT EQUIPMENT CO. SUPPLIED LOADLINE EQUIPMENT DEDUCTIONS:  
 DOWNHAUL WEIGHT.....225 lbs  
 ONE SHEAVE BLOCK.....424 lbs  
 TWO SHEAVE BLOCK.....592 lbs  
 THREE SHEAVE BLOCK.....639 lbs  
 FOUR SHEAVE BLOCK.....762 lbs  
 AUXILIARY SHEAVE.....100 lbs

CRANE MEETS ASME B30.5 REQUIREMENTS AT TIME OF MANUFACTURE

1204090 111914

**RANGE CHART - MAIN BOOM, FULL-SPAN OUTRIGGERS**



**MODEL 3400 142-ft BOOM**

**RANGE DIAGRAM WITH FULL SPAN OUTRIGGERS**

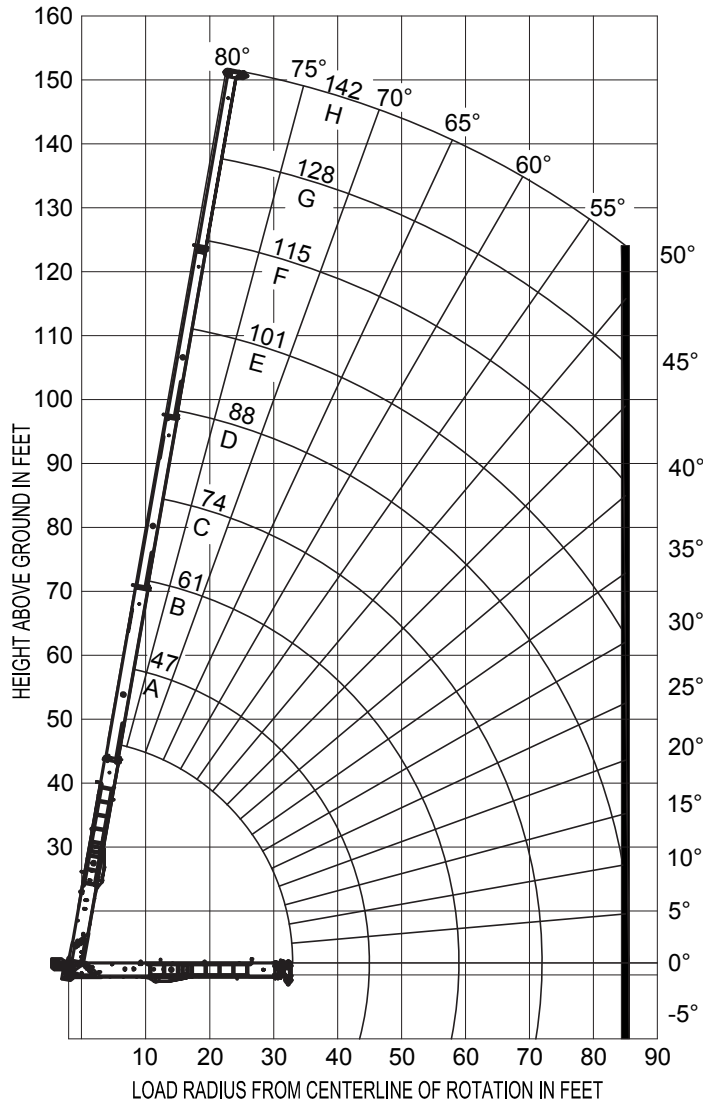

- NOTE:**
1. Boom load ratings are based on loaded boom radius. Loaded boom angles are given as reference only.
  2. Capacities do not exceed 85% stability.
  3. Personnel handling is allowed only with full span outriggers.

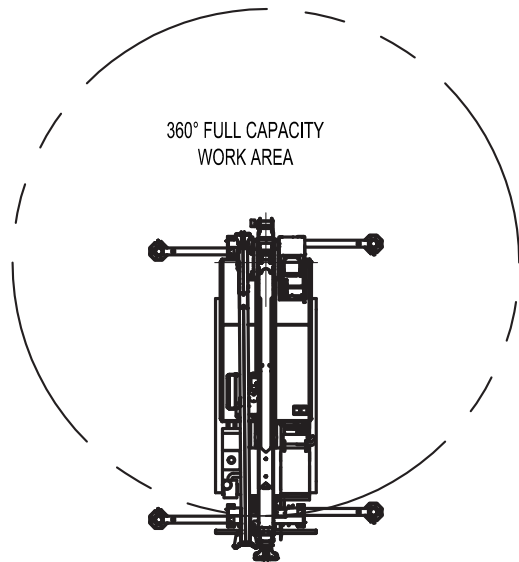

CRANE MEETS ASME B30.5 REQUIREMENTS AT TIME OF MANUFACTURE

1204090 111914

**RANGE CHART - JIB + WORK PLATFORM, FULL-SPAN OUTRIGGERS**



**MODEL 3400 142-ft BOOM**

**RANGE DIAGRAM WITH PLATFORM ATTACHED AND 32 / 49 FT PLATFORM EXTENSION**

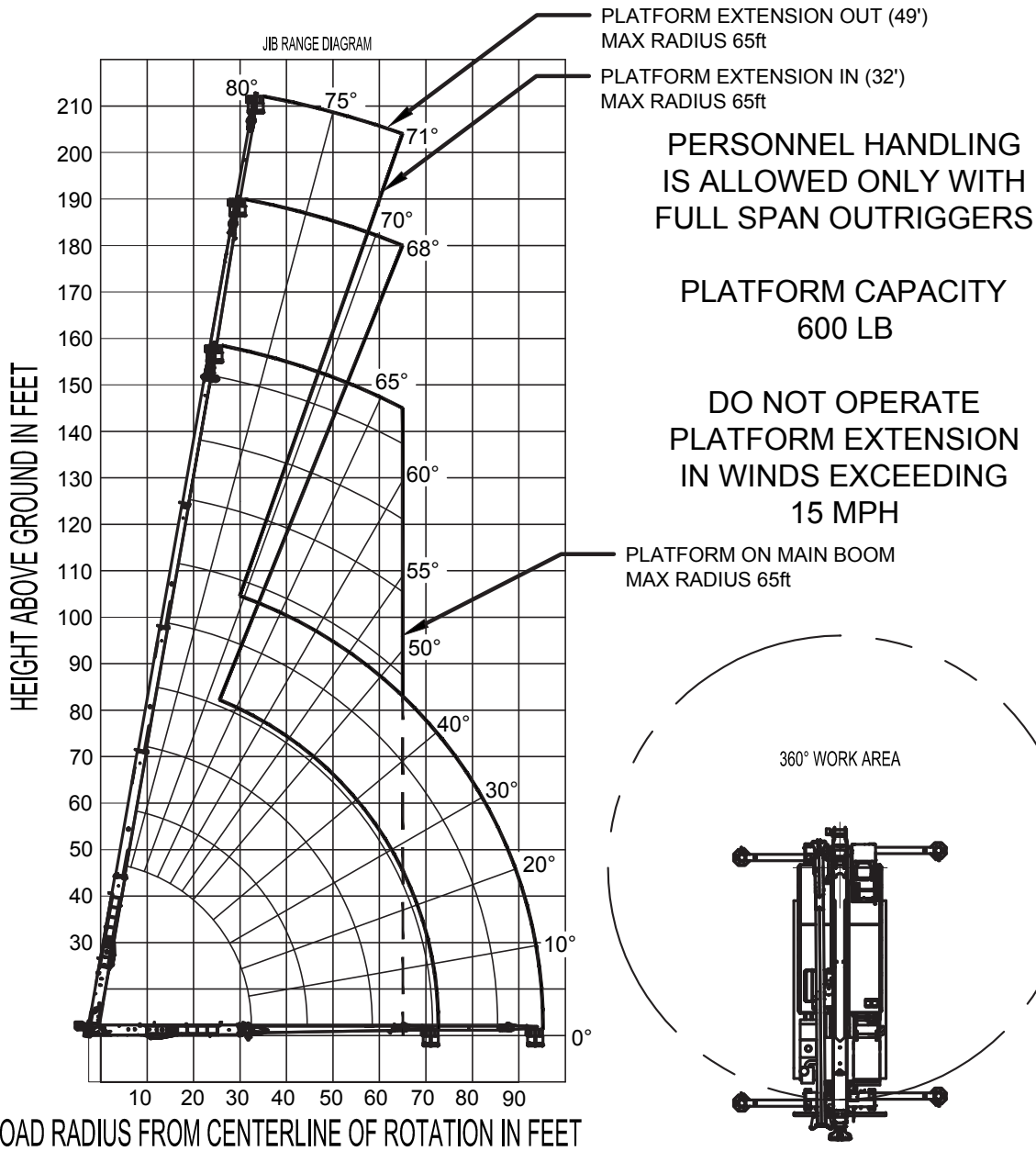

CRANE MEETS ASME B30.5 REQUIREMENTS AT TIME OF MANUFACTURE

1204090 111914



Elliott Equipment Company  
 3514 South 25th Street  
 Omaha, NE 68105  
 Phone: 402-592-4500  
 Fax: 402-592-4553  
 Email: sales@elliottequip.com

**Built for You.**  
[www.elliottequip.com](http://www.elliottequip.com)

**WINCH DATA**



**MODEL 3400**

**142-ft BOOM**

**PARTS OF LINE**

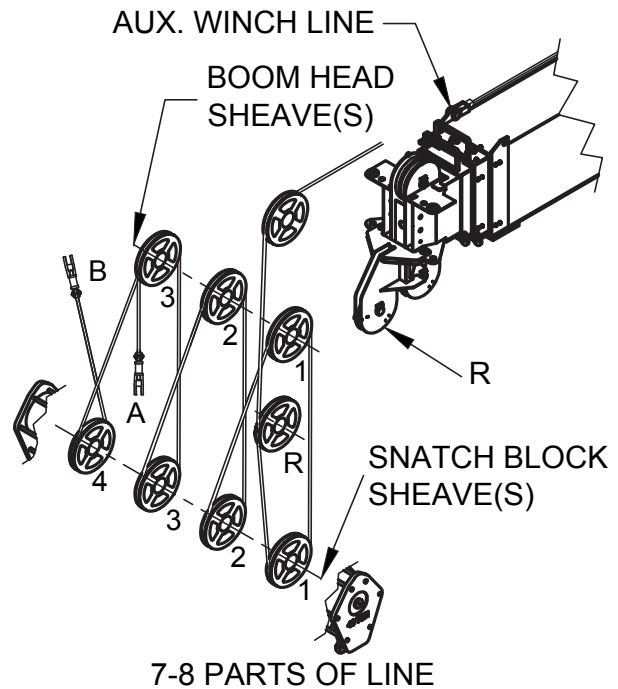
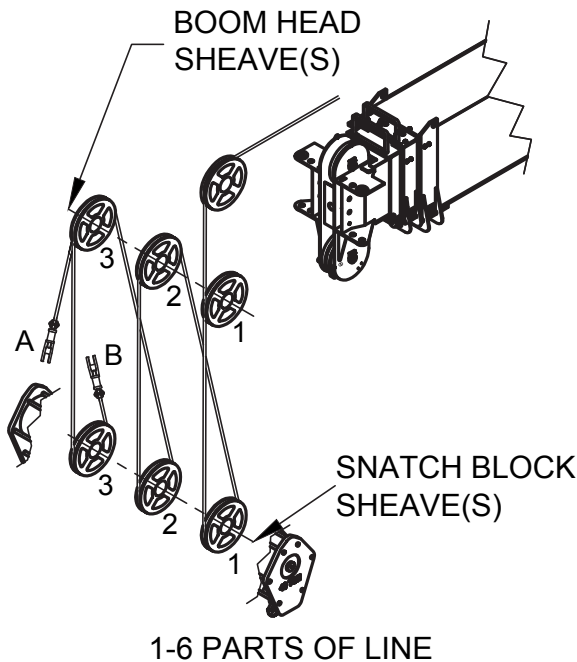

**NOTICE:**

- DO NOT DEADHEAD LINE BLOCK AGAINST BOOM TIP WHEN EXTENDING BOOM.
- KEEP AT LEAST 5 WRAPS OF LOADLINE ON THE WINCH DRUM AT ALL TIMES.
- USE ONLY 9/16" DIAMETER WIRE ROPE, AS SPECIFIED, WITH THE PROPER BREAKING STRENGTH LISTED.
- ANTI-TWO-BLOCK SYSTEM MUST BE IN GOOD OPERATING CONDITION BEFORE OPERATING CRANE. SEE OPERATION & SAFETY MANUAL.

PARTS OF LINE	SHEAVE(S) ON BOOM HEAD	SHEAVE(S) ON SNATCH BLOCK	9/16" - SPIN RESISTANT (5:1 S.F.) 45,300-lbs. BREAKING STRENGTH
1	1	A	9,060 lbs
2	1 B	1	18,120 lbs
3	12	1 A	27,180 lbs
4	12 B	12	36,240 lbs
5	123	12 A	45,300 lbs
6	123 B	123	54,360 lbs
7	R 123	123 A	63,420 lbs
8	R 123 B	1234	68,000 lbs

A-DEAD END FOR ODD PARTS OF LINE  
 B-DEAD END FOR EVEN PARTS OF LINE  
 R-ROOSTER SHEAVE REQUIRED WHEN USING 7 AND 8 PARTS OF LINE

CRANE MEETS ASME B30.5 REQUIREMENTS AT TIME OF MANUFACTURE

1204090 111914



Elliott Equipment Company  
 3514 South 25th Street  
 Omaha, NE 68105  
 Phone: 402-592-4500  
 Fax: 402-592-4553  
 Email: sales@elliottequip.com

**Built for You.**  
[www.elliottequip.com](http://www.elliottequip.com)

**TRACK VEHICLE SPECIFICATIONS**

	34142 BoomTruck
Overall Length	330" / 838 cm
Overall Width	134" / 340 cm
Overall Height	116" / 295cm
Payload Capacity	40,000 lbs / 18 144 kg
Electrical System	12 Volt
Drive System	Hydrostatic

Chassis data is minimum general requirements-not for engineering.  
 Actual dimensions and track vehicle data will depend on machine selection and configuration.  
 \*Minimum chassis weight is required to meet 85% stability requirements.

**OPTIONS**



**Radio Remote Control**

Interference protected radio remotes let you get closer to your work and have full control over your machine. Includes battery charging feature and optional LMI screen.

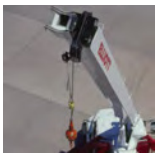

**Pin-On Jib Attachment**

Two piece telescoping jib that stows on the side of the boom for easy placement while on the job site.



**Brush Guard**

Heavy-duty steel brush guard prevents tree limbs and other materials from damaging the vehicle or obscuring visibility.



**High-Power Recovery Winch**

A front mounted recovery winch improves equipment recovery in extreme environments like mud, sand or swamp.



**Operator Cab**

The optional enclosed crane operator cab includes windshield wipers, intuitive control systems, and optional heating and air conditioning.



**Hook Block for Multi-Part Line**

Elliott can install up to a 7-part hook block to improve lifting capabilities. The block can stored on the bed for transport.



**2-Man Yoke Work Platform**

Elliott's new 1,200 lb capacity 2-man platform features a hydraulic yoke lifting system for easy attachment to the boom tip. Fully OSHA compliant and heavy duty.

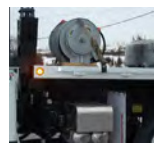

**Body Mounted Hose Reels and Circuits**

Let us work with you to customize your tool compatability by adding hose reels or hydraulic circuits to the crane bed.

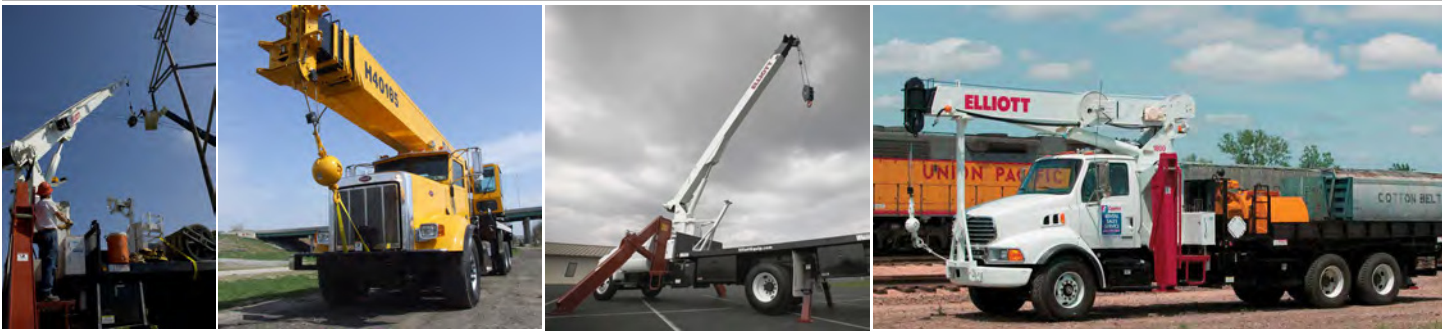

### 36127F SIDE VIEW DIAGRAM

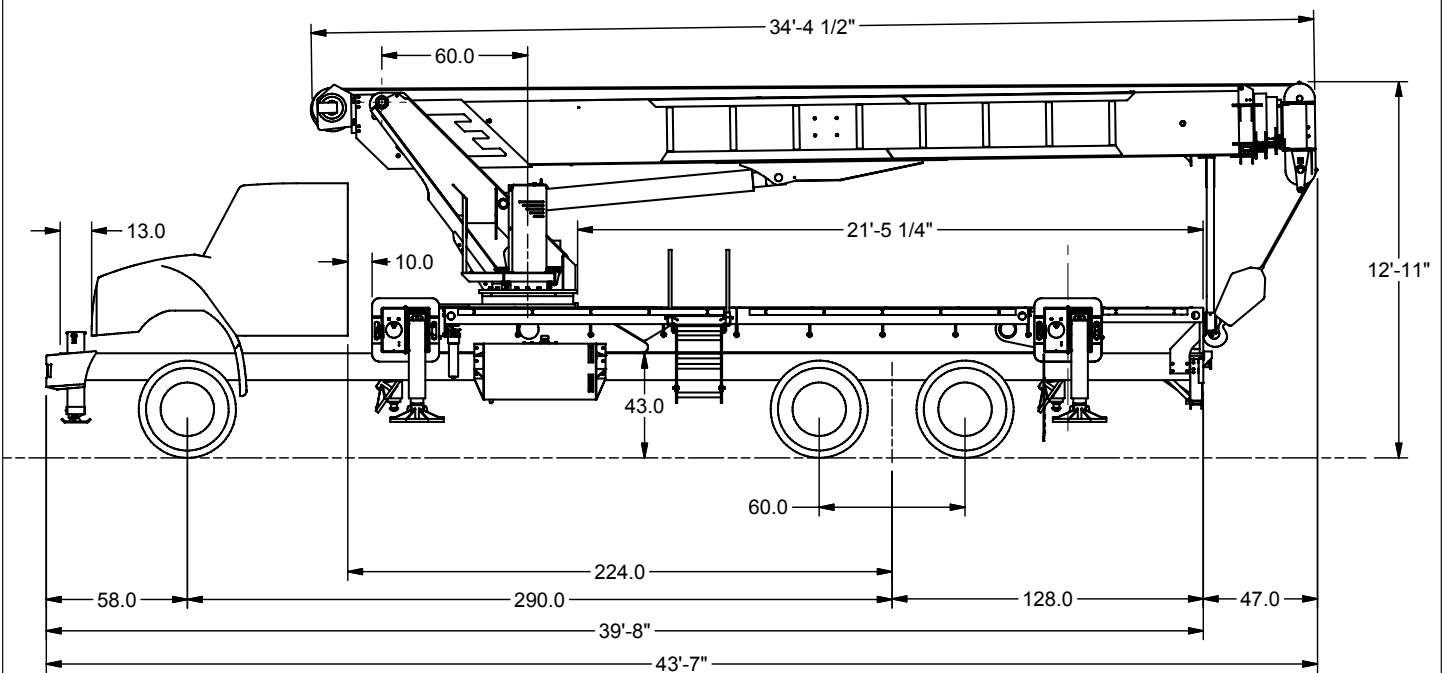

- |                                  |                                     |                                 |                  |
|----------------------------------|-------------------------------------|---------------------------------|------------------|
| • <b>Maximum Vertical Reach</b>  | 186'57 m                            | • <b>Powered Boom Sections</b>  | 5                |
| • <b>Working Area</b>            | 180 Degrees Standard (360 Optional) | • <b>Overall Height</b>         | 12'11"/3,9 m     |
| • <b>Lifting Capacity</b>        | 72,000 lbs/32 659 kg                | • <b>Operator Controls</b>      | Rotating Standup |
| • <b>Boom Length</b>             | 127'/39m                            | • <b>Outrigger Type Front</b>   | Out-Down         |
| • <b>Crane Weight (Standard)</b> | 33,585 lbs/15 234 kg                | • <b>Outrigger Spread Front</b> | 21'2"/6,4 m      |
| • <b>Jib Lengths</b>             | 32-49'/ 10-15 m                     | • <b>Outrigger Type Rear</b>    | Out-Down         |
| • <b>Winch Bare Drum Pull</b>    | 12,800 lbs/5806 kg                  | • <b>Outrigger Spread Rear</b>  | 21'2"/6,4 m      |

## TECHNICAL SPECIFICATIONS

**Crane Capacity:** 72,000 lbs at 5' load radius.

**Maximum Tip Height:** 137' height (186' with optional 49' jib)

**Control Console:** Rotating turret single operator standup control station equipped with four single axis control levers for the main crane controls. Operator station includes LMI display, bubble level gauge, engine start/stop switch, signal horn button, variable speed throttle switch, lifting capacity chart, range diagram chart, boom angle indicator, system pressure gauge, 12V DC power source, and cup holder. Independent ground level electric operated outrigger controls.

**Boom:** Five-section fully proportional, high strength steel plated rectangular tube sections. A maximum boom tip height of 137' mounted on a truck. The boom nose contains one floating upper sheave and three lower sheaves. Assembly includes heavy-duty cylinder fittings, pivot pins, and replaceable wear pads.

**Winch:** Mounted at the base of the boom for a long fleet angle and flat level spooling of cable. Winch is driven by a planetary reducer and powered by a hydraulic motor. Burst-of-speed winch provides increased line speed. The winch brake is spring applied, pressure release design. Supplied with 425' of 9/16" diameter rotation resistant wire rope with a single line pull of 9,060 pounds, and a downhaul ball with swivel hook for single part line.

**Load Moment Indicator System:** System senses hoist cylinder pressures, boom length and boom angle with hydraulic function lockout. The display console is equipped with a bar graph showing crane utilization, boom angle or boom length, a mode select controls for main boom and jib operation, and an anti-two block with an audio/visual warning and shut-off functions to limit

hook-boom point contact.

**Outriggers:** Two sets of out and down overframe outriggers with 21'2" span. Outriggers are configured for full span or mid span operation. Outriggers equipped with ball socket aluminum removable pads that stow on vertical outrigger legs.

**Frame:** Full length, all welded rigid 4-plate design sub-frame. Sub-frame allows for bolt-on addition of 21'5" aluminum bed wings, with top plate of subbase serving as a portion of the bed deck, to form a three-piece bed.

**Turret:** Reverse offset turret is one-piece weldment. Turret rotates on large diameter ball bearing.

**Rotation:** Hydraulic motor drives turret through double reduction planetary swing drive for continuous rotation. The swing drive system has a spring applied, pressure release brake.

**Lift:** One double-acting long stroke cylinder provides smooth and stable boom elevation. Holding valve prevents boom from falling in event of hose failure.

**Boom Extension:** Incorporates a 2-stage hydraulic extension cylinder, attached to the largest boom section, with a proportional cable extension system driving the outermost sections.

**Hoses:** All high pressure hoses are wire braid reinforced with a minimum safety factor of 4 to 1.

**Cylinders:** All cylinders use microhoned cylinder tubing, chrome shafts, top grade packing and protective rod wipers. Cylinder-mounted holding valves provided on all load-holding cylinders.

**Hydraulic System:** Equipped with air-shift PTO, piston pump, SAE O-ring face seals on pressure lines, and a 10-micron return line filter. The control valve distributes all flow to hoist system, swing circuit, and other crane functions.

System is closed center type.

**Oil Tank Capacity:** 120 gallon mounted to truck frame on roadside.

**Cab Equipment:** PTO with indicator lights installed in truck cab. U/L approved 5:BC dry chemical fire extinguisher installed in truck cab.

**Operators Manual & Video:** Two CD copies and one hard copy of operation, maintenance, safety and parts manual provided with each unit. Operational and safety video provided at delivery.

**Installation:** Unit installed on chassis, painted, system and tank filled with oil, tested, inspected, and ready to operate.

**Standard Paint:** Paint turret and boom white, outriggers red, and boxes black.

**Bumper:** Bureau of Motor Carrier Safety rear bumper.

**Weight:** Approximately 33,585 lbs. with 21'5" bed wings less truck.

**Truck Chassis Required:** Approx. 224" C.T. RBM 3,300,000 in-lb. per rail, 20,000 lb. front axle and 66,000 lb. GVWR required. Trucks must have front frame extension, 12V electrical system with high capacity alternator, cab clearance stop/tail/backup lights, and I.D. lamps. Recommended GVWR is minimum for BOOMTRUCK with flatbed only. Contact factory when additional equipment is to be added.

**Options:**

32' to 49' 2 Piece Telescopic Jib

Radio Remote Controls

Gravity-Leveled Steel Basket

Tool Box Configurations

Front Jack for 360 Degree Crane Operation

Line Blocks for Multi-Part Line

Hydraulic Oil Cooler

Much more....

Elliott Equipment Company reserves the right to change the specification of any unit at any time without prior notice. This brochure is only a statement of general specifications on the date of this publication. For more detailed info on specific Elliott trucks go to [www.elliottequip.com](http://www.elliottequip.com)

**LOAD CHART - MAIN BOOM, FULL-SPAN OUTRIGGERS**



**MODEL 3600 127-ft BOOM**  
LOAD RATINGS WITH FULLY EXTENDED OUTRIGGERS

**MAIN BOOM LOAD RATINGS (lbs)**

LOAD RADIUS IN FEET	LOADED BOOM ANGLE	MAIN BOOM LOAD RATINGS (lbs)										
		32-ft	A	B	C	D	E					
5	73.0	72,000										
8	67.0	54,000										
10	63.0	48,000	73.2	36,000								
12	60.0	43,000	70.9	36,000								
15	53.0	33,500	67.4	31,000	74.7	28,000						
20	40.0	23,550	61.3	24,300	69.5	23,000	76.0	18,000				
25	23.0	17,400	54.8	18,200	66.0	18,000	72.5	17,500	77.0	14,200	80.0	8,800
30			47.7	14,000	62.0	14,300	69.0	14,500	74.2	12,900	77.5	8,400
35			39.7	11,150	56.5	11,400	65.0	11,500	71.0	11,400	75.0	8,000
40			30.1	8,950	51.9	9,000	61.0	9,400	68.0	9,500	72.5	7,500
45			15.9	7,250	45.5	7,500	57.0	7,700	65.0	7,800	70.0	7,000
50					40.0	6,100	53.5	6,300	61.5	6,400	67.0	6,450
55						33.0	5,000	49.5	5,200	58.5	5,300	5,350
60						24.0	4,000	45.2	4,200	55.0	4,300	4,400
65								40.5	3,300	51.3	3,500	3,550
70								34.0	2,600	48.0	2,700	2,800
75								28.0	2,050	44.4	2,150	2,200
80								20.0	1,500	40.6	1,600	1,700
85										36.5	1,150	1,200
90										31.5	800	850
95											40.0	500
	0	15,550	0	6,900	0	3,200	0	1,100				
		1,000		650		450		400		300		250
									30.0		40.0	
									90°			

**JIB LOAD RATINGS (lbs)**

32-49 ft. EXTENDABLE JIB					
LOAD RADIUS (FT)	LOADED BOOM ANGLE	32ft. JIB RETRACTED	49-ft. JIB EXTENDED		
			LOAD RADIUS (FT)	LOADED BOOM ANGLE	49-ft. JIB EXTENDED
30	80.0	3,400			
46	75.0	3,200	33	80.0	2,200
60	70.0	2,700	50	75.0	2,200
73	65.0	2,100	65	70.0	1,600
85	60.0	1,700	80	65.0	1,000
95	55.0	1,200			

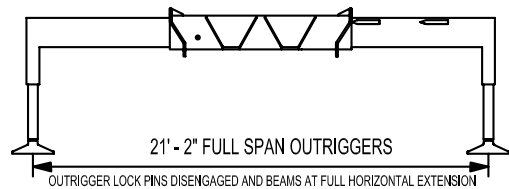

ELLIOTT EQUIPMENT CO. SUPPLIED  
LOADLINE EQUIPMENT DEDUCTIONS:  
DOWNHAUL WEIGHT ..... 180 lbs  
ONE SHEAVE BLOCK ..... 236 lbs  
TWO SHEAVE BLOCK ..... 291 lbs  
THREE SHEAVE BLOCK ..... 639 lbs  
FOUR SHEAVE BLOCK ..... 762 lbs  
AUXILIARY SHEAVE ..... 100 lbs

**DEDUCTIONS FOR STOWED EXTENDABLE JIB (lbs)**

MINIMUM BOOM ANGLE (°) FOR INDICATED LENGTH (NO LOAD)	30.0	40.0
MAXIMUM BOOM LENGTH (FT) AT 0° BOOM ANGLE (NO LOAD)		

**1-PART LINE 2-PART LINE 3-PART LINE 4-PART LINE 5-PART LINE 6-PART LINE 7-PART LINE 8-PART LINE**



**NOTICE**

- DO NOT DEADHEAD LINE BLOCK AGAINST BOOM TIP WHEN EXTENDING BOOM.
- KEEP AT LEAST 5 WRAPS OF LOADLINE ON THE WINCH DRUM AT ALL TIMES.
- USE ONLY 9/16" DIAMETER WIRE ROPE, AS SPECIFIED BELOW, WITH THE PROPER BREAKING STRENGTHS LISTED.
- ANTI-TWO-BLOCK SYSTEM MUST BE IN GOOD OPERATING CONDITION BEFORE OPERATING CRANE. SEE OPERATION & SAFETY MANUAL.

MAX PULL: 9,600 lbs	19,200 lbs	28,800 lbs	38,400 lbs	48,000 lbs	57,600 lbs	67,200 lbs	72,000 lbs
MAX PULL: 9,060 lbs	18,120 lbs	27,180 lbs	36,240 lbs	45,300 lbs	54,360 lbs	63,420 lbs	72,000 lbs

9/16" - 6 x 37 IWRC (3,51 S.F.)  
33,600-lbs. BREAKING STRENGTH  
9/16" - SPIN RESISTANT (S1 S.F.)  
45,300-lbs. BREAKING STRENGTH

CRANE MEETS ASME B30.5 REQUIREMENTS AT TIME OF MANUFACTURE

DO NOT PAINT OVER ANY LABELS 1172320 022311



Elliott Equipment Company  
3514 South 25th Street  
Omaha, NE 68105  
Phone: 402-592-4500  
Fax: 402-592-4553  
Email: sales@elliottequip.com

**Built for You.**  
www.elliottequip.com



**RANGE CHART - MAIN BOOM + JIB, FULL-SPAN OUTRIGGERS**



**MODEL 3600**

**127-ft BOOM**

**RANGE DIAGRAM WITH FULL SPAN OUTRIGGERS**

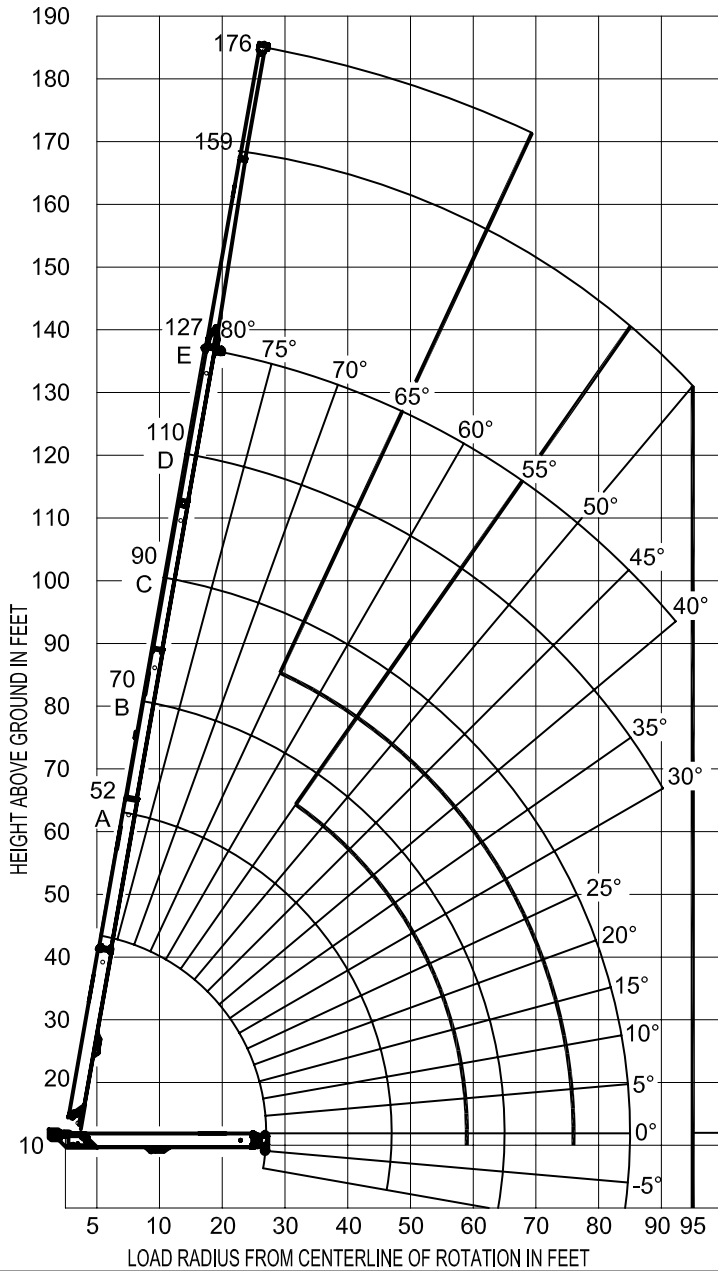

BOOM DEFLECTION NOT SHOWN

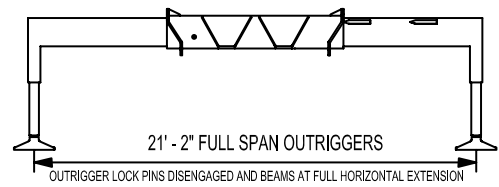

**NOTE:**

1. Operate jib by radius when main boom is fully extended. Increase boom angle if necessary to maintain load radius.
2. When boom is retracted, operate jib by boom angles. Do not exceed any rated jib capacities at reduced boom lengths.
3. Capacities do not exceed 85% stability.
4. Load ratings above bold line are structurally limited.
5. Personnel handling is allowed only with full span outriggers.
6. Boom load ratings are based on loaded boom radius. Loaded boom angles are given as reference only.

**AREA OF OPERATION:**

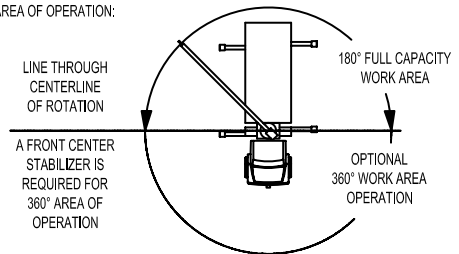

**STABILITY LIMIT LINE (NO LOAD)**

CRANE MEETS ASME B30.5 REQUIREMENTS AT TIME OF MANUFACTURE

DO NOT PAINT OVER ANY LABELS

1172320 022311



Elliott Equipment Company  
3514 South 25th Street  
Omaha, NE 68105  
Phone: 402-592-4500  
Fax: 402-592-4553  
Email: sales@elliottequip.com

**Built for You.**  
www.elliottequip.com

**RANGE CHART - MAIN BOOM + JIB, MID-SPAN OUTRIGGERS**



**MODEL 3600 127-ft BOOM**

**RANGE DIAGRAM WITH OUTRIGGERS IN MID-SPAN POSITION**

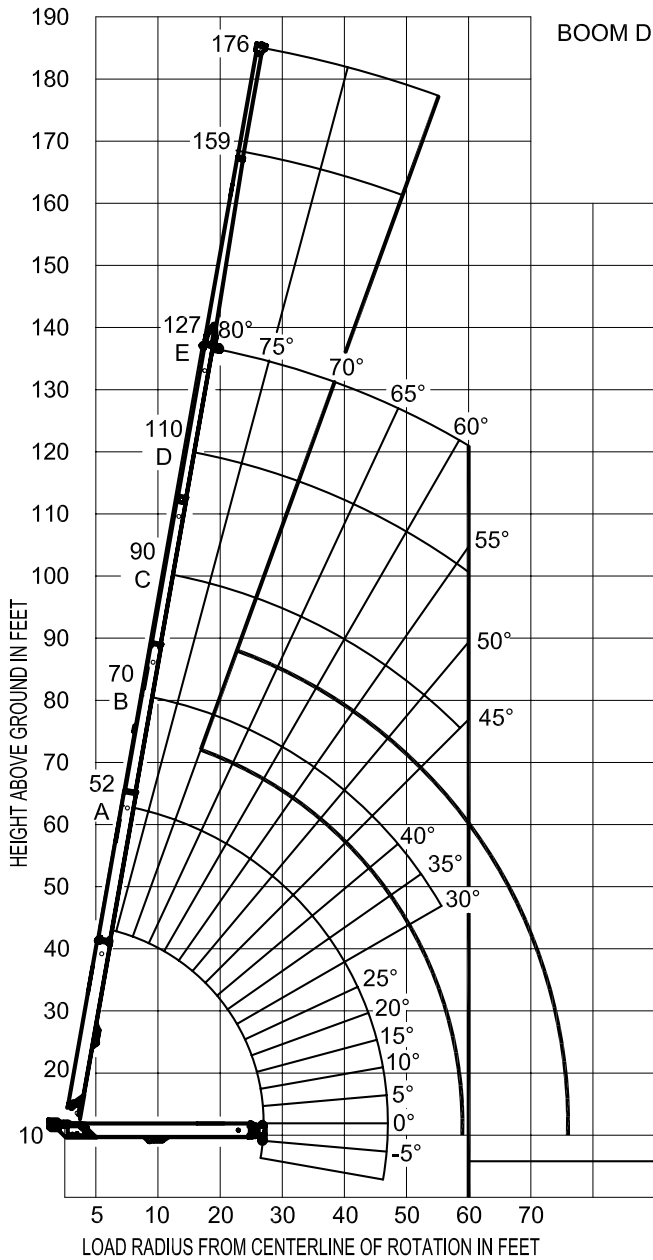

BOOM DEFLECTION NOT SHOWN

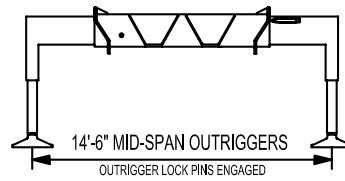

**NOTE:**

1. Operate jib by radius when main boom is fully extended. Increase boom angle if necessary to maintain load radius.
2. When boom is retracted, operate jib by boom angles. Do not exceed any rated jib capacities at reduced boom lengths.
3. Capacities do not exceed 85% stability.
4. Load ratings above bold line are structurally limited.
5. Personnel handling is allowed only with full span outriggers.
6. Boom load ratings are based on loaded boom radius. Loaded boom angles are given as reference only.

**AREA OF OPERATION:**

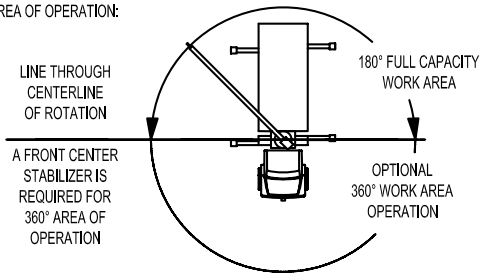

**STABILITY LIMIT LINE (NO LOAD)**

CRANE MEETS ASME B30.5 REQUIREMENTS AT TIME OF MANUFACTURE

DO NOT PAINT OVER ANY LABELS

1172320 022311



Elliott Equipment Company  
 3514 South 25th Street  
 Omaha, NE 68105  
 Phone: 402-592-4500  
 Fax: 402-592-4553  
 Email: sales@elliottequip.com

**Built for You.**  
 www.elliottequip.com

**TRUCK CHASSIS SPECIFICATIONS**

	36127F BoomTruck
Wheelbase (WB)	290" / 736 cm
Cab to Tandem (CT)	224" / 569 cm
Cab to End of Frame (EOF)	352" / 894 cm
Frame Section Modulus	30.0 in <sup>3</sup> -110,000 psi / 492 cm <sup>3</sup> -758,428 kPa
Front Axle Gross Weight Rating	20,000 lb / 9072 kg
Rear Axle Gross Weight Rating	53,200 lb / 24 131 kg (13,200 lb Pusher Axle)
Integral Front Frame Rails	Required for Front Stabilizer

Chassis data is minimum general requirements-not for engineering.  
 Actual dimensions and truck data will depend on truck selection and axle configuration.  
 \*Minimum chassis weight is required to meet 85% stability requirements.

**OPTIONS**



**Radio Remote Control**

Interference protected radio remotes let you get closer to your work and have full control over your machine. Includes battery charging feature and optional LMI screen.

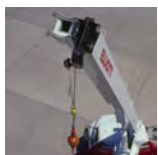

**Pin-On Jib Attachments**

Two piece telescoping jib with material handling and basket attachment capabilities. Stows on the side of the boom for easy placement while on the worksite.



**Hydraulic Oil Cooler**

Add a bed-mounted hydraulic oil cooler to assist with high duty cycle job applications.



**Automatic Safety Rotation Lockout**

“Short-jack” your BoomTruck by adding an automatic safety lockout to prevent boom movement over the side where outriggers are not fully extended.



**Tool Boxes**

Optional tool boxes and bed storage can accommodate any storage need for tools, work materials and more.

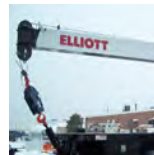

**Hook Block for Multi-Part Line**

Elliott can install a 2-3 part hook block or a 4 part-hook block to improve lifting capabilities. The block can store right on the rear of the bed.



**Gravity Levelled Work Platform**

Elliott’s new 600 lb capacity 2-man platform features a hydraulic yoke lifting system for easy attachment to the boom tip. Fully OSHA compliant and heavy duty.

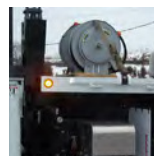

**Body Mounted Hose Reels and Circuits**

Let us work with you to customize your tool compatibility by adding hose reels or hydraulic circuits to the crane bed.

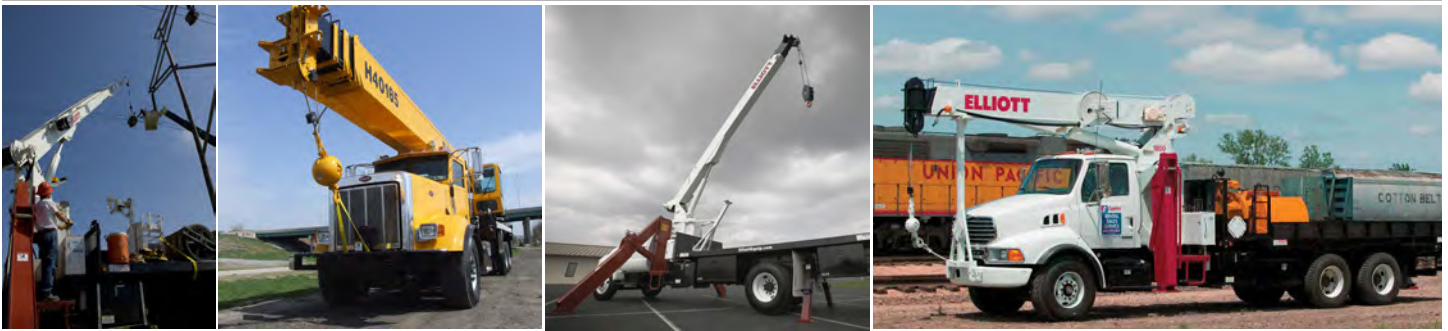

### 36127R SIDE VIEW DIAGRAM

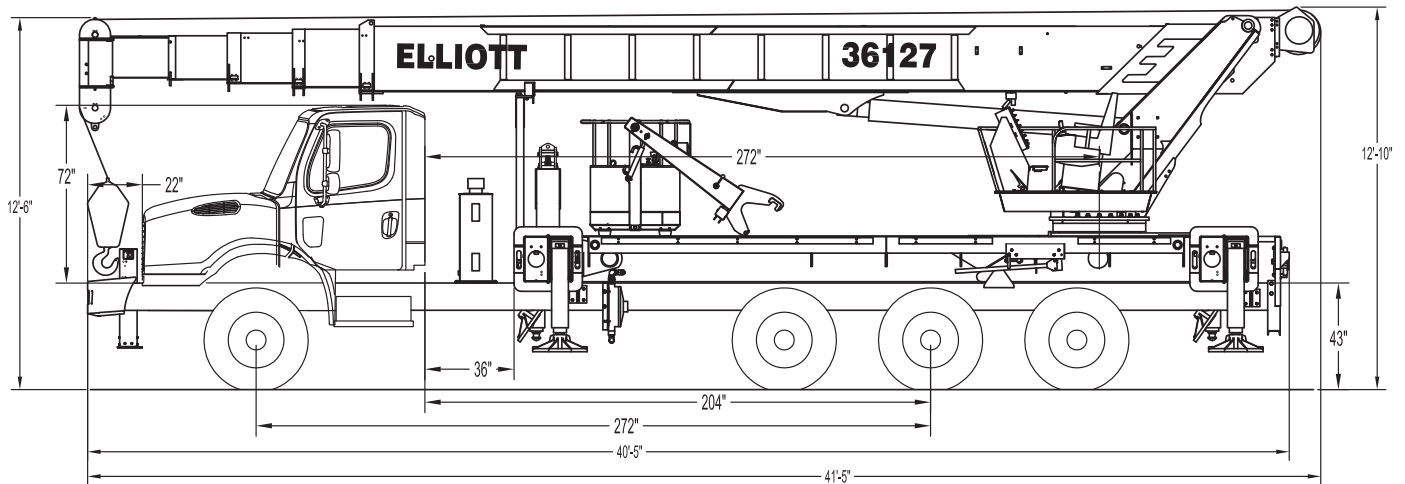

- |                                  |                      |                                 |                  |
|----------------------------------|----------------------|---------------------------------|------------------|
| • <b>Maximum Vertical Reach</b>  | 186'/56,7 m          | • <b>Powered Boom Sections</b>  | 5                |
| • <b>Working Area</b>            | 360 Degrees          | • <b>Overall Height</b>         | 12'10"/3,9 m     |
| • <b>Lifting Capacity</b>        | 72,000 lbs/32 659 kg | • <b>Operator Controls</b>      | Rotating Standup |
| • <b>Boom Length</b>             | 127'/39m             | • <b>Outrigger Type Front</b>   | Out-Down         |
| • <b>Crane Weight (Standard)</b> | 33,585 lbs/15 234 kg | • <b>Outrigger Spread Front</b> | 21'2"/6,4 m      |
| • <b>Jib Lengths</b>             | 32-49'/10-15 m       | • <b>Outrigger Type Rear</b>    | Out-Down         |
| • <b>Winch Bare Drum Pull</b>    | 12,800 lbs/5806 kg   | • <b>Outrigger Spread Rear</b>  | 21'2"/6,4 m      |

## TECHNICAL SPECIFICATIONS

**Crane Capacity:** 72,000 lbs at 5' load radius.

**Maximum Tip Height:** 137' height (186' with optional 49' jib)

**Control Console:** Rotating turret single operator standup control station equipped with four single axis control levers for the main crane controls. Operator station includes LMI display, bubble level gauge, engine start/stop switch, signal horn button, variable speed throttle switch, lifting capacity chart, range diagram chart, boom angle indicator, system pressure gauge, 12V DC power source, and cup holder. Independent ground level electric operated outrigger controls.

**Boom:** Five-section fully proportional, high strength steel plated rectangular tube sections. A maximum boom tip height of 137' mounted on a truck. The boom nose contains one floating upper sheave and three lower sheaves. Assembly includes heavy-duty cylinder fittings, pivot pins, and replaceable wear pads.

**Winch:** Mounted at the base of the boom for a long fleet angle and flat level spooling of cable. Winch is driven by a planetary reducer and powered by a hydraulic motor. Burst-of-speed winch provides increased line speed. The winch brake is spring applied, pressure release design. Supplied with 425' of 9/16" diameter rotation resistant wire rope with a single line pull of 9,060 pounds, and a downhaul ball with swivel hook for single part line.

**Load Moment Indicator System:** System senses hoist cylinder pressures, boom length and boom angle with hydraulic function lockout. The display console is equipped with a bar graph showing crane utilization, boom angle or boom length, a mode select controls for main boom and jib operation, and an anti-two block with an audio/visual warning and shut-off functions to limit

hook-boom point contact.

**Outriggers:** Two sets of out and down overframe outriggers with 21'2" span. Outriggers are configured for full span or mid span operation. Outriggers equipped with ball socket aluminum removable pads that stow on vertical outrigger legs. Single front bumper stabilizer.

**Frame:** Full length, all welded rigid 4-plate design sub-frame. Sub-frame allows for bolt-on addition of 20' aluminum bed wings, with top plate of subbase serving as a portion of the bed deck, to form a three-piece bed.

**Turret:** Reverse offset turret is one-piece weldment. Turret rotates on large diameter ball bearing.

**Rotation:** Hydraulic motor drives turret through double reduction planetary swing drive for continuous rotation. The swing drive system has a spring applied, pressure release brake.

**Lift:** One double-acting long stroke cylinder provides smooth and stable boom elevation. Holding valve prevents boom from falling in event of hose failure.

**Boom Extension:** Incorporates a 2-stage hydraulic extension cylinder, attached to the largest boom section, with a proportional cable extension system driving the outermost sections.

**Hoses:** All high pressure hoses are wire braid reinforced with a minimum safety factor of 4 to 1.

**Cylinders:** All cylinders use microhoned cylinder tubing, chrome shafts, top grade packing and protective rod wipers. Cylinder-mounted holding valves provided on all load-holding cylinders.

**Hydraulic System:** Equipped with air-shift PTO, piston pump, SAE O-ring face seals on pressure lines, and a 10-micron return line filter. The control valve distributes all flow to hoist system,

swing circuit, and other crane functions. System is closed center type.

**Oil Tank Capacity:** 143 gallon mounted on truck frame.

**Cab Equipment:** PTO switch with indicator lights installed in truck cab. U/L approved 5:BC dry chemical fire extinguisher installed in truck cab.

**Operators Manual & Video:** Two CD copies and one hard copy of operation, maintenance, safety and parts manual provided with each unit. Operational and safety video provided at delivery.

**Installation:** Unit installed on chassis, painted, system and tank filled with oil, tested, inspected, and ready to operate.

**Standard Paint:** Paint turret and boom white, outriggers red, and boxes black.

**Bumper:** Bureau of Motor Carrier Safety rear bumper.

**Weight:** Approximately 33,585 lbs. with 20' bed wings less truck.

**Truck Chassis Required:** Approx. 200" C.T. RBM 3,300,000 in-lb. per rail, 20,000 lb. front axle and 78,000 lb. GVWR recommended. Trucks must have 12V electrical system with high capacity alternator, cab clearance stop/tail/backup lights, and I.D. lamps. Contact factory when additional equipment is to be added.

**Options:**

Enclosed Operator Cab  
Open Seated Lower Controls  
32' to 49' Two-Piece Telescopic Jib  
Radio Remote Controls  
Gravity-Leveled Steel Basket  
Tool Box Configurations  
Line Blocks for Multi-Part Line  
Hydraulic Oil Cooler  
Much more....

Elliott Equipment Company reserves the right to change the specification of any unit at any time without prior notice. This brochure is only a statement of general specifications on the date of this publication. For more detailed info on specific Elliott trucks go to [www.elliottequip.com](http://www.elliottequip.com)

**LOAD CHART - MAIN BOOM, FULL-SPAN OUTRIGGERS**



**MODEL 3600 127-ft BOOM**  
LOAD RATINGS WITH FULLY EXTENDED OUTRIGGERS

**MAIN BOOM LOAD RATINGS (lbs)**

LOAD RADIUS IN FEET	LOADED BOOM ANGLE	MAIN BOOM LOAD RATINGS (lbs)												
		32-ft	A	B	C	D	E	30-ft	52-ft	70-ft	90-ft	110-ft	127-ft	
5	73.0	72,000												
8	67.0	54,000												
10	63.0	48,000	73.2	36,000										
12	60.0	43,000	70.9	36,000										
15	53.0	33,500	67.4	31,000	74.7	28,000								
20	40.0	23,550	61.3	24,300	69.5	23,000	76.0	18,000						
25	23.0	17,400	54.8	18,200	66.0	18,000	72.5	17,500	77.0	14,200	80.0	8,800		
30			47.7	14,000	62.0	14,300	69.0	14,500	74.2	12,900	77.5	8,400		
35			39.7	11,150	56.5	11,400	65.0	11,500	71.0	11,400	75.0	8,000		
40			30.1	8,950	51.9	9,000	61.0	9,400	68.0	9,500	72.5	7,500		
45			15.9	7,250	45.5	7,500	57.0	7,700	65.0	7,800	70.0	7,000		
50					40.0	6,100	53.5	6,300	61.5	6,400	67.0	6,450		
55					33.0	5,000	49.5	5,200	58.5	5,300	64.5	5,350		
60					24.0	4,000	45.2	4,200	55.0	4,300	62.0	4,400		
65							40.5	3,300	51.3	3,500	59.5	3,550		
70							34.0	2,600	48.0	2,700	56.0	2,800		
75							28.0	2,050	44.4	2,150	53.5	2,200		
80							20.0	1,500	40.6	1,600	50.0	1,700		
85									36.5	1,150	44.0	1,200		
90									31.5	800	44.3	850		
95											40.0	500		
	0	15,550	0	6,900	0	3,200	0	1,100						
		1,000		650		450		400		300		250		
									30.0		40.0			
									90'					

**JIB LOAD RATINGS (lbs)**

32-49 ft. EXTENDABLE JIB					
LOAD RADIUS (FT)	LOADED BOOM ANGLE	32ft. JIB RETRACTED	LOAD RADIUS (FT)	LOADED BOOM ANGLE	49-ft. JIB EXTENDED
30	80.0	3,400			
46	75.0	3,200	33	80.0	2,200
60	70.0	2,700	50	75.0	2,200
73	65.0	2,100	65	70.0	1,600
85	60.0	1,700	80	65.0	1,000
95	55.0	1,200			

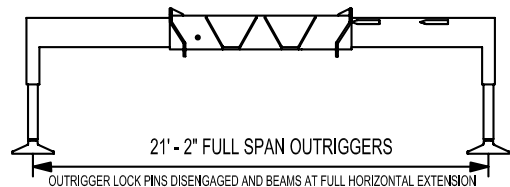

ELLIOTT EQUIPMENT CO. SUPPLIED  
LOADLINE EQUIPMENT DEDUCTIONS:  
DOWNHAUL WEIGHT .....180 lbs  
ONE SHEAVE BLOCK.....236 lbs  
TWO SHEAVE BLOCK.....291 lbs  
THREE SHEAVE BLOCK.....639 lbs  
FOUR SHEAVE BLOCK.....762 lbs  
AUXILIARY SHEAVE.....100 lbs

DEDUCTIONS FOR STOWED EXTENDABLE JIB (lbs)  
MINIMUM BOOM ANGLE (°) FOR INDICATED LENGTH (NO LOAD)  
MAXIMUM BOOM LENGTH (FT) AT 0° BOOM ANGLE (NO LOAD)

**1-PART LINE 2-PART LINE 3-PART LINE 4-PART LINE 5-PART LINE 6-PART LINE 7-PART LINE 8-PART LINE**

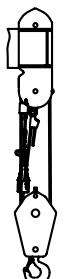

**NOTICE**

- DO NOT DEADHEAD LINE BLOCK AGAINST BOOM TIP WHEN EXTENDING BOOM.  
- KEEP AT LEAST 5 WRAPS OF LOADLINE ON THE WINCH DRUM AT ALL TIMES.  
- USE ONLY 9/16\"/>

MAX PULL: 9,600 lbs	19,200 lbs	28,800 lbs	38,400 lbs	48,000 lbs	57,600 lbs	67,200 lbs	72,000 lbs	9/16\"/>
MAX PULL: 9,060 lbs	18,120 lbs	27,180 lbs	36,240 lbs	45,300 lbs	54,360 lbs	63,420 lbs	72,000 lbs	

CRANE MEETS ASME B30.5 REQUIREMENTS AT TIME OF MANUFACTURE

DO NOT PAINT OVER ANY LABELS

1172320 022311



**RANGE CHART - MAIN BOOM + JIB, FULL-SPAN OUTRIGGERS**



**MODEL 3600**

**127-ft BOOM**

**RANGE DIAGRAM WITH FULL SPAN OUTRIGGERS**

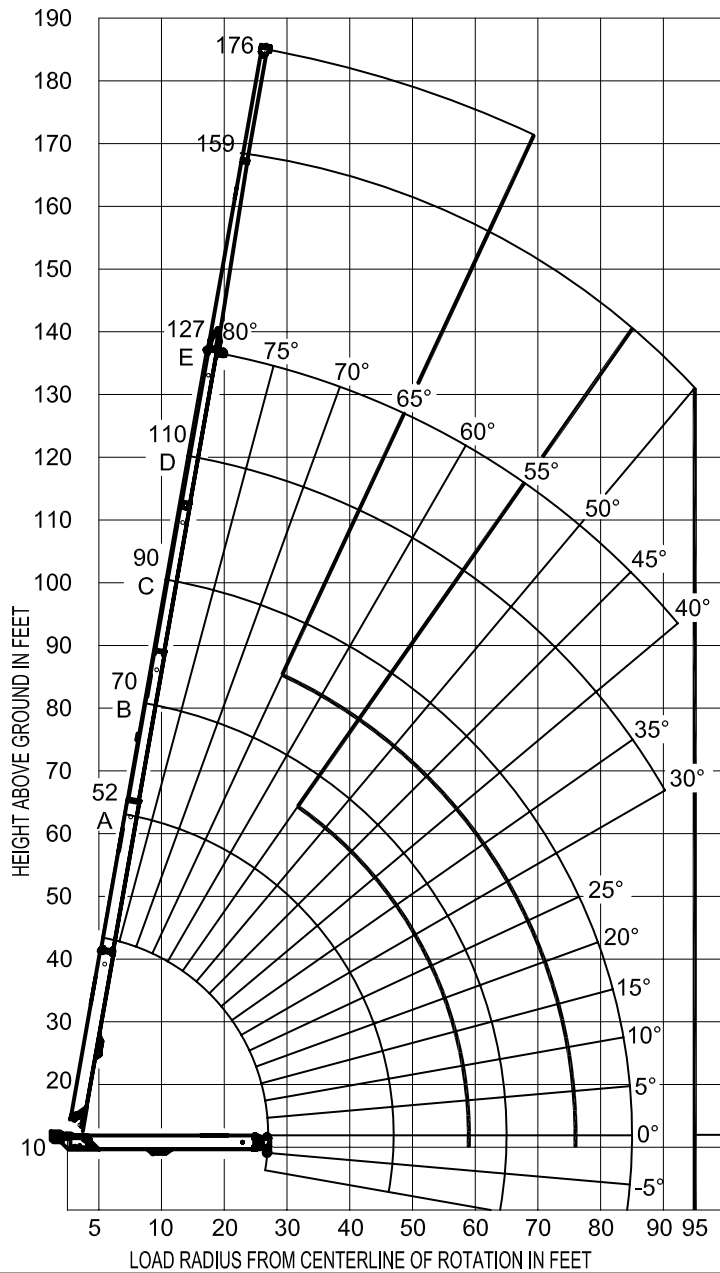

BOOM DEFLECTION NOT SHOWN

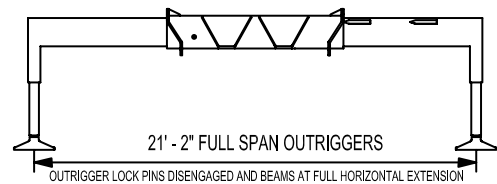

**NOTE:**

1. Operate jib by radius when main boom is fully extended. Increase boom angle if necessary to maintain load radius.
2. When boom is retracted, operate jib by boom angles. Do not exceed any rated jib capacities at reduced boom lengths.
3. Capacities do not exceed 85% stability.
4. Load ratings above bold line are structurally limited.
5. Personnel handling is allowed only with full span outriggers.
6. Boom load ratings are based on loaded boom radius. Loaded boom angles are given as reference only.

**AREA OF OPERATION:**

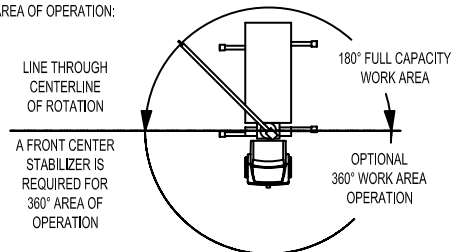

**STABILITY LIMIT LINE (NO LOAD)**

CRANE MEETS ASME B30.5 REQUIREMENTS AT TIME OF MANUFACTURE

DO NOT PAINT OVER ANY LABELS

1172320 022311



Elliott Equipment Company  
3514 South 25th Street  
Omaha, NE 68105  
Phone: 402-592-4500  
Fax: 402-592-4553  
Email: sales@elliottequip.com

**Built for You.**  
www.elliottequip.com

**RANGE CHART - MAIN BOOM + JIB, MID-SPAN OUTRIGGERS**



**MODEL 3600 127-ft BOOM**

**RANGE DIAGRAM WITH OUTRIGGERS IN MID-SPAN POSITION**

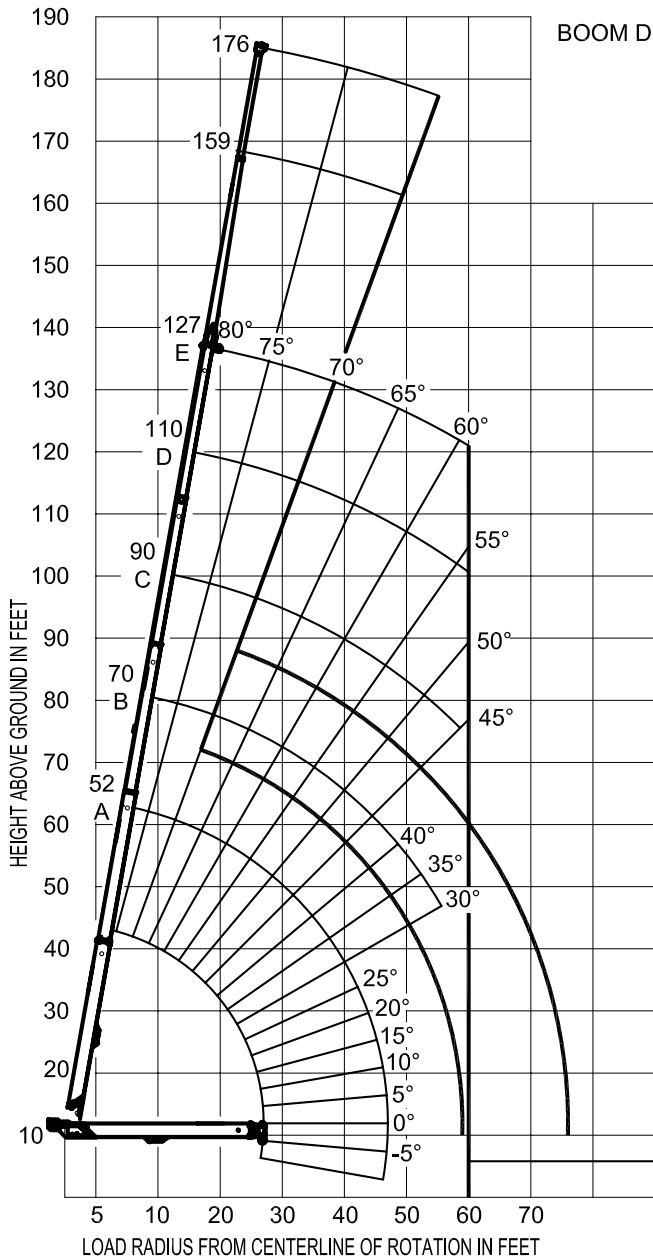

BOOM DEFLECTION NOT SHOWN

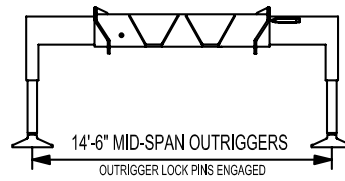

**NOTE:**

1. Operate jib by radius when main boom is fully extended. Increase boom angle if necessary to maintain load radius.
2. When boom is retracted, operate jib by boom angles. Do not exceed any rated jib capacities at reduced boom lengths.
3. Capacities do not exceed 85% stability.
4. Load ratings above bold line are structurally limited.
5. Personnel handling is allowed only with full span outriggers.
6. Boom load ratings are based on loaded boom radius. Loaded boom angles are given as reference only.

**AREA OF OPERATION:**

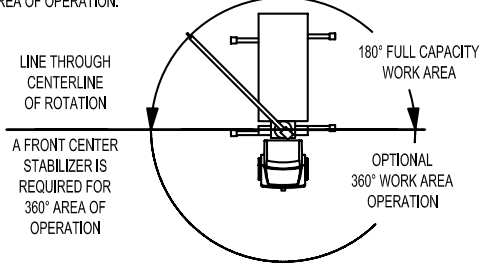

**STABILITY LIMIT LINE (NO LOAD)**

CRANE MEETS ASME B30.5 REQUIREMENTS AT TIME OF MANUFACTURE

DO NOT PAINT OVER ANY LABELS

1172320 022311



Elliott Equipment Company  
 3514 South 25th Street  
 Omaha, NE 68105  
 Phone: 402-592-4500  
 Fax: 402-592-4553  
 Email: sales@elliottequip.com

**Built for You.**  
[www.elliottequip.com](http://www.elliottequip.com)

**RECOMMENDED CHASSIS SPECIFICATIONS**

	36127R BoomTruck
Wheelbase (WB)	286" / 726 cm
Cab to Axle (CA)	200" / 508 cm
Cab to End of Frame (EOF)	320" / 813 cm
Frame Section Modulus	30.0 in <sup>3</sup> -110,000 psi / 492 cm <sup>3</sup> -758,428 kPa
Front Axle Gross Weight Rating	20,000 lb / 9072 kg
Rear Axle Gross Weight Rating	53,200 lb / 24 131 kg (13,200 lb Pusher Axle)
Integral Front Frame Rails	Required for Front Stabilizer

Chassis data is minimum general requirements-not for engineering.  
 Actual dimensions and truck data will depend on truck selection and axle configuration.  
 \*Minimum chassis weight is required to meet 85% stability requirements.

**OPTIONS**



**Radio Remote Control**

Interference protected radio remotes let you get closer to your work and have full control over your machine. Includes battery charging feature and optional LMI screen.

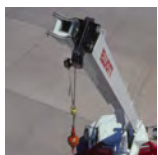

**Pin-On Jib Attachments**

Two piece telescoping jib with material handling and basket attachment capabilities. Stows on the side of the boom for easy placement while on the worksite.



**Hydraulic Oil Cooler**

Add a hydraulic oil cooler to assist with high duty cycle job applications.



**Automatic Safety Rotation Lockout**

“Short-jack” your BoomTruck by adding an automatic safety lockout to prevent boom movement over the side where outriggers are not fully extended.



**Tool Boxes**

Optional tool boxes and bed storage can accommodate any storage need for tools, work materials and more.

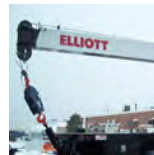

**Hook Block for Multi-Part Line**

Elliott can install a 2-3 part hook block or a 4 part-hook block to improve lifting capabilities. The block can be stored towards the front of the bed.



**Gravity Levelled Basket**

Elliott’s new 600 lb capacity 2-man platform features a hydraulic yoke lifting system for easy attachment to the boom tip. Fully OSHA compliant and heavy duty.

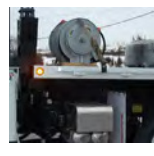

**Body Mounted Hose Reels and Circuits**

Let us work with you to customize your tool compatibility by adding hose reels or hydraulic circuits to the crane bed.

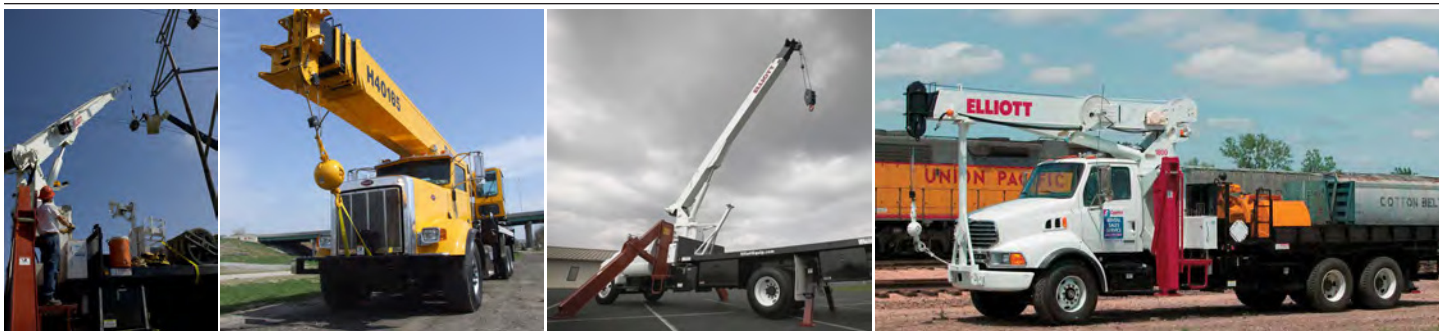

### 36142 SIDE VIEW DIAGRAM

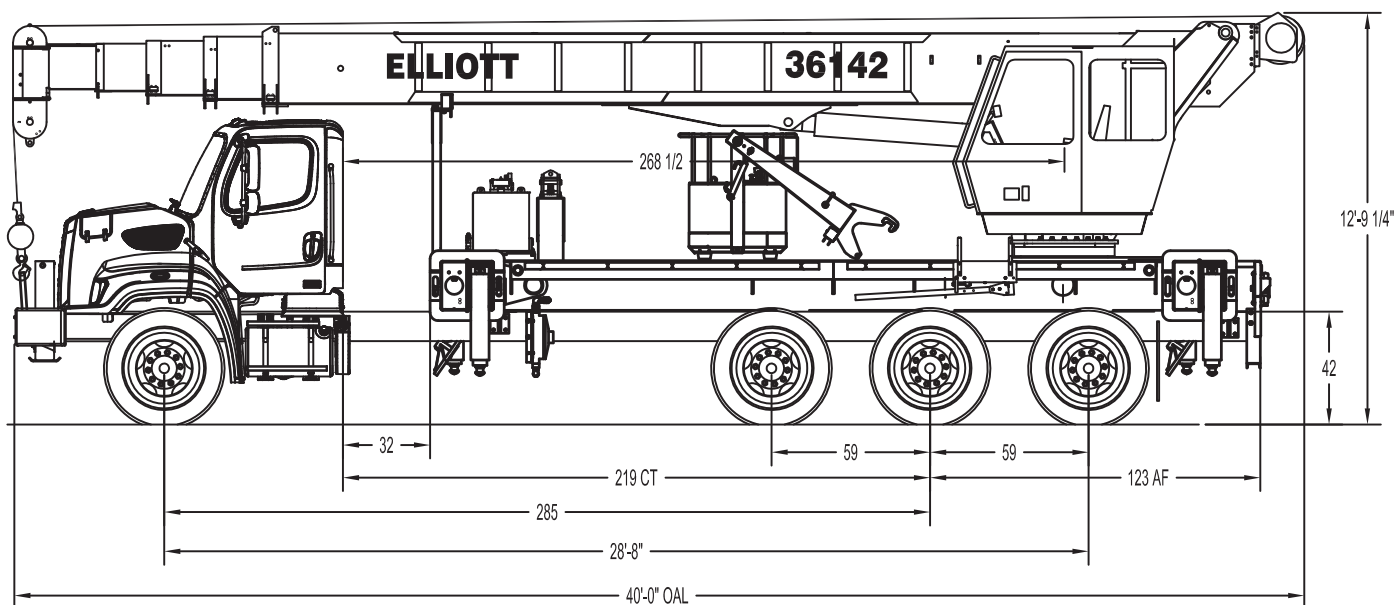

- |                                  |                      |                                       |                  |
|----------------------------------|----------------------|---------------------------------------|------------------|
| • <b>Maximum Vertical Reach</b>  | 201'61,3 m           | • <b>Powered Boom Sections</b>        | 5                |
| • <b>Working Area</b>            | 360 Degrees          | • <b>Overall Height</b>               | 12'10"/3,9 m     |
| • <b>Lifting Capacity</b>        | 72,000 lbs/32 659 kg | • <b>Operator Controls (Standard)</b> | Rotating Standup |
| • <b>Boom Length</b>             | 142'/43,3 m          | • <b>Outrigger Type Front</b>         | Out-Down         |
| • <b>Crane Weight (Standard)</b> | 35,210 lbs/15 971 kg | • <b>Outrigger Spread Front</b>       | 21'2"/6,4 m      |
| • <b>Jib Lengths</b>             | 32'-49'/10-15 m      | • <b>Outrigger Type Rear</b>          | Out-Down         |
| • <b>Winch Bare Drum Pull</b>    | 12,800 lbs/5806 kg   | • <b>Outrigger Spread Rear</b>        | 21'2"/6,4 m      |

## TECHNICAL SPECIFICATIONS

**Crane Capacity:** 72,000 lbs at 5' load radius.

**Maximum Tip Height:** 152' height (201' with optional 32'-49' jib)

**Control Console:** Rotating turret single operator standup control station equipped with four single axis control levers for the main crane controls. Operator station includes LMI display, bubble level gauge, engine start/stop switch, signal horn button, variable speed throttle switch, lifting capacity chart, range diagram chart, boom angle indicator, system pressure gauge, 12V DC power source, and cup holder. Independent ground level electric operated outrigger controls.

**Boom:** Five-section fully proportional, high strength steel plated rectangular tube sections. A maximum boom tip height of 152' mounted on a truck. The boom nose contains one floating upper sheave and three lower sheaves. Assembly includes heavy-duty cylinder fittings, pivot pins, and replaceable wear pads.

**Winch:** Mounted at the base of the boom for a long fleet angle and flat level spooling of cable. Winch is driven by a planetary reducer and powered by a hydraulic motor. Burst-of-speed winch provides increased line speed. The winch brake is spring applied, pressure release design. Supplied with 425' of 9/16" diameter rotation resistant wire rope with a single line pull of 9,060 pounds, and a downhaul ball with swivel hook for single part line.

**Load Moment Indicator System:** System senses hoist cylinder pressures, boom length and boom angle with hydraulic function lockout. The display console is equipped with a bar graph showing crane utilization, boom angle or boom length, a mode select controls for main boom and jib operation, and an anti-two block with an audio/visual warning and shut-off functions to limit

hook-boom point contact.

**Outriggers:** Two sets of out and down overframe outriggers with 21'2" span. Outriggers are configured for full span or mid span operation. Outriggers equipped with ball socket aluminum removable pads that stow on vertical outrigger legs. Single front bumper stabilizer.

**Frame:** Full length, all welded rigid 4-plate design sub-frame. Sub-frame allows for bolt-on addition of 20' aluminum bed wings, with top plate of subbase serving as a portion of the bed deck, to form a three-piece bed.

**Turret:** Reverse offset turret is one-piece weldment. Turret rotates on large diameter ball bearing.

**Rotation:** Hydraulic motor drives turret through double reduction planetary swing drive for continuous rotation. The swing drive system has a spring applied, pressure release brake.

**Lift:** One double-acting long stroke cylinder provides smooth and stable boom elevation. Holding valve prevents boom from falling in event of hose failure.

**Boom Extension:** Incorporates a 2-stage hydraulic extension cylinder, attached to the largest boom section, with a proportional cable extension system driving the outermost sections.

**Hoses:** All high pressure hoses are wire braid reinforced with a minimum safety factor of 4 to 1.

**Cylinders:** All cylinders use microhoned cylinder tubing, chrome shafts, top grade packing and protective rod wipers. Cylinder-mounted holding valves provided on all load-holding cylinders.

**Hydraulic System:** Equipped with air-shift or hot shift PTO, piston pump, SAE O-ring face seals on pressure lines, and a 10-micron return line filter. The control valve distributes all flow to hoist

system, swing circuit, and other crane functions. System is closed center type.

**Oil Tank Capacity:** 119 gallon aluminum reservoir mounted on outrigger or truck frame.

**Cab Equipment:** PTO with indicator lights installed in truck cab. U/L approved 5:BC dry chemical fire extinguisher installed in truck cab.

**Operators Manual & Video:** Two CD copies and one hard copy of operation, maintenance, safety and parts manual provided with each unit. Operational and safety video provided at delivery.

**Installation:** Unit installed on chassis, painted, system and tank filled with oil, tested, inspected, and ready to operate.

**Standard Paint:** Paint turret and boom white, outriggers red, and boxes black.

**Bumper:** Bureau of Motor Carrier Safety rear bumper.

**Weight:** Approximately 35,210 lbs. with 20' bed wings less truck.

**Truck Chassis Required:** Approx. 219" C.T., 3,200,000 in-lb RBM frame rails, 20,000 lb. front axle and 78,000 lb. GVWR recommended. Truck must have a front frame extension, 12V electrical system with high capacity alternator, cab clearance stop/tail/backup lights, and I.D. lamps. Contact factory when additional equipment is to be added.

**Options:**

Enclosed Operator Cab with Heater  
Open Seated Rotating Control Station  
32' to 49' Two-Piece Telescopic Jib  
Radio Remote Controls  
Gravity-Leveled Steel Basket  
Line Blocks for Multi-Part Line  
Hydraulic Oil Cooler  
Toolbox Storage Options  
Much more....

Elliott Equipment Company reserves the right to change the specification of any unit at any time without prior notice. This brochure is only a statement of general specifications on the date of this publication. For more detailed info on specific Elliott trucks go to [www.elliottequip.com](http://www.elliottequip.com)

**LOAD CHART - MAIN BOOM, FULL-SPAN OUTRIGGERS**



**MODEL 3600 142-ft BOOM**  
LOAD RATINGS WITH FULLY EXTENDED OUTRIGGERS

**MAIN BOOM LOAD RATINGS (LBS)**

LOAD RADIUS IN FEET	LOADED BOOM ANGLE	35-FT	A	LOADED BOOM ANGLE	47-FT	B	LOADED BOOM ANGLE	61-FT	C	LOADED BOOM ANGLE	74-FT	D	LOADED BOOM ANGLE	88-FT	E	LOADED BOOM ANGLE	101-FT	F	LOADED BOOM ANGLE	115-FT	G	LOADED BOOM ANGLE	128-FT	H	LOADED BOOM ANGLE	142-FT
5	71.7	72,000																								
8	68.2	48,000																								
10	64.6	41,000	71.4	40,000																						
12	60.9	35,900	68.8	34,000	73.8	30,000																				
15	55.2	28,000	64.8	26,500	70.9	24,500	74.3	24,000																		
20	44.4	20,000	57.9	20,000	65.8	20,000	70.3	17,500	73.5	17,000																
25	31.0	15,000	50.3	15,500	60.5	15,500	66.1	15,000	70.1	14,500	72.7	13,200	74.9	12,000												
30			41.9	12,000	55.0	12,000	61.8	12,400	66.6	12,400	69.7	11,300	72.3	10,500	74.1	8,500										
35			31.7	9,400	49.0	9,700	57.3	10,200	63.0	10,200	66.7	9,400	69.6	9,500	71.8	8,200	73.6	6,000								
40			16.8	7,200	42.5	8,000	52.5	8,400	59.2	8,400	63.5	8,200	67.0	8,300	69.4	7,700	71.5	5,700								
45					34.9	6,500	47.5	6,800	55.4	6,800	60.7	7,000	64.2	7,200	67.0	6,600	69.4	5,500								
50					25.6	5,100	42.0	5,500	51.3	5,500	57.0	5,500	61.4	5,600	64.6	5,600	67.2	5,200								
55					10.4	4,400	35.8	4,500	47.0	4,600	53.6	4,600	58.6	4,700	62.0	4,700	65.0	4,400								
60							28.6	3,600	42.4	3,700	49.9	3,700	55.6	3,800	59.5	3,800	62.8	3,600								
65							18.9	2,800	37.3	3,000	46.1	3,000	52.5	3,100	56.8	3,100	60.5	3,000								
70									31.5	2,200	42.0	2,200	49.3	2,400	54.1	2,400	58.1	2,200								
75									24.6	1,500	37.6	1,600	45.9	1,700	51.3	1,700	55.7	1,700								
80									15.0	800	32.7	1,150	42.3	1,150	48.4	1,200	53.2	1,250								
85											27.0	800	38.5	800	45.3	850	50.7	850								
90															42.1	600	48.0	600								
95																										
	0	11,500	0	6,500	0	4,000	0	1,300																		
		900		650		500		400		350		300		250		250		200								

**JIB LOAD RATINGS**

(LBS)		
32-49 FT EXTENDABLE JIB		
LOAD RADIUS (FT)	LOADED BOOM ANGLE	32 FT JIB RETRACTED
33	80.0	3,400
44	75.0	3,200
58	70.0	2,700
70	65.0	1,500
80	62.0	1,000
49-FT JIB EXTENDED		
LOAD RADIUS (FT)	LOADED BOOM ANGLE	49-FT JIB EXTENDED
35	80.0	2,200
50	75.0	2,200
70	70.0	1,600
80	65.0	1,000

DEDUCTIONS FOR STOWED EXTENDABLE JIB (LBS)

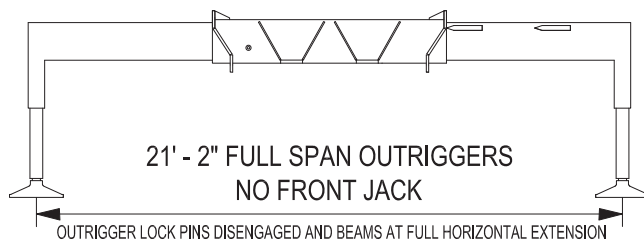

**ELLIOTT EQUIPMENT CO. SUPPLIED LOADLINE EQUIPMENT DEDUCTIONS:**  
 DOWNHAUL WEIGHT .....180 LBS  
 ONE SHEAVE BLOCK.....236 LBS  
 TWO SHEAVE BLOCK.....291 LBS  
 THREE SHEAVE BLOCK.....639 LBS  
 FOUR SHEAVE BLOCK.....762 LBS  
 AUXILIARY SHEAVE.....100 LBS

1-PART LINE	2-PART LINE	3-PART LINE	4-PART LINE	5-PART LINE	6-PART LINE	7-PART LINE	8-PART LINE
MAX PULL: 9,600 lbs	19,200 lbs	28,800 lbs	38,400 lbs	48,000 lbs	57,600 lbs	67,200 lbs	72,000 lbs
MAX PULL: 9,060 lbs	18,120 lbs	27,180 lbs	36,240 lbs	45,300 lbs	54,360 lbs	63,420 lbs	72,000 lbs

**NOTICE**  
 - DO NOT DEADHEAD LINE BLOCK AGAINST BOOM TIP WHEN EXTENDING BOOM.  
 - KEEP AT LEAST 5 WRAPS OF LOADLINE ON THE WINCH DRUM AT ALL TIMES.  
 - USE ONLY 9/16" DIAMETER WIRE ROPE, AS SPECIFIED BELOW, WITH THE PROPER BREAKING STRENGTHS LISTED.  
 - ANTI-TWO-BLOCK SYSTEM MUST BE IN GOOD OPERATING CONDITION BEFORE OPERATING CRANE. SEE OPERATION & SAFETY MANUAL.  
 9/16" - 6 x 37 IWRC (3.5:1 S.F.) 33,000-lbs. BREAKING STRENGTH  
 9/16" - SPIN RESISTANT (5:1 S.F.) 45,300-lbs. BREAKING STRENGTH  
 1214820 072216

CRANE MEETS ASME B30.5 REQUIREMENTS AT TIME OF MANUFACTURE



Elliott Equipment Company Phone: 402-592-4500  
 3514 South 25th Street Fax: 402-592-4553  
 Omaha, NE 68105 Email: sales@elliottequip.com

**Built for You.**  
 www.elliottequip.com

**LOAD CHART - MAIN BOOM, MID-SPAN OUTRIGGERS**



**MODEL 3600 142-FT BOOM**  
LOAD RATINGS WITH OUTRIGGERS AT MID-SPAN POSITION

MAIN BOOM LOAD RATINGS (LBS)														JIB LOAD RATINGS							
LOAD RADIUS IN FEET	LOADED BOOM ANGLE	35-FT	LOADED BOOM ANGLE	A 47-FT	LOADED BOOM ANGLE	B 61-FT	LOADED BOOM ANGLE	C 74-FT	LOADED BOOM ANGLE	D 88-FT	LOADED BOOM ANGLE	E 101-FT	LOADED BOOM ANGLE	F 115-FT	LOADED BOOM ANGLE	G 128-FT	LOADED BOOM ANGLE	H 142-FT	(LBS)		
5	71.7	72,000																	32-49 FT EXTENDABLE JIB		
8	68.2	48,000																	LOAD RADIUS (FT)	LOADED BOOM ANGLE	32 FT JIB RETRACTED
10	64.6	41,000	71.4	40,000														33	80.0	3,400	
12	60.9	35,900	68.8	34,000	73.8	30,000												44	75.0	3,200	
15	55.2	28,000	64.8	26,500	70.9	24,500	74.3	24,000										49-FT JIB EXTENDED			
20	44.4	18,000	57.9	18,800	65.8	19,000	70.3	17,500	73.5	17,000								LOAD RADIUS (FT)	LOADED BOOM ANGLE	49-FT JIB EXTENDED	
25	31.0	11,000	50.3	11,800	60.5	12,000	66.1	12,300	70.1	12,500	72.7	12,900	74.9	12,000				35	80.0	2,200	
30			41.9	7,800	55.0	8,100	61.8	8,400	66.6	8,600	69.7	8,800	72.3	8,900	74.1	8,500		50	75.0	2,200	
35			31.7	5,200	49.0	5,600	57.3	5,800	63.0	6,000	66.7	6,200	69.6	6,300	71.8	6,400	73.6	DEDUCTIONS FOR STOWED EXTENDABLE JIB (LBS)			
40			16.8	3,500	42.5	3,800	52.5	4,000	59.2	4,200	63.5	4,400	67.0	4,500	69.4	4,500	71.5	35	80.0	2,200	
45					34.9	2,500	47.5	2,700	55.4	2,800	60.7	3,000	64.2	3,100	67.0	3,200	69.4	30	75.0	2,200	
50					25.6	1,500	42.0	1,700	51.3	1,800	57.0	2,000	61.4	2,200	64.6	2,200	67.2	25	75.0	2,200	
55					10.4	700	35.8	900	47.0	1,000	53.6	1,200	58.6	1,300	62.0	1,400	65.0	20			
60											49.9	600	55.6	600	59.5	700	62.8	15			
65																		10			
70																		5			
75																		0			
80																					
85																					
90																					
95																					
	0	7,100	0	3,000	0	600	0														
		900		650		500		400		350		300		250		250		200			

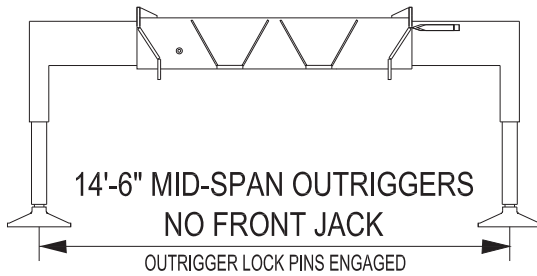

- ELLIOTT EQUIPMENT CO. SUPPLIED LOADLINE EQUIPMENT DEDUCTIONS:
- DOWNHAUL WEIGHT .....180 LBS
  - ONE SHEAVE BLOCK.....236 LBS
  - TWO SHEAVE BLOCK.....291 LBS
  - THREE SHEAVE BLOCK.....639 LBS
  - FOUR SHEAVE BLOCK.....762 LBS
  - AUXILIARY SHEAVE.....100 LBS

1-PART LINE	2-PART LINE	3-PART LINE	4-PART LINE	5-PART LINE	6-PART LINE	7-PART LINE	8-PART LINE	NOTICE
								<ul style="list-style-type: none"> <li>• DO NOT DEADHEAD LINE BLOCK AGAINST BOOM TIP WHEN EXTENDING BOOM.</li> <li>• KEEP AT LEAST 5 WRAPS OF LOADLINE ON THE WINCH DRUM AT ALL TIMES.</li> <li>• USE ONLY 9/16" DIAMETER WIRE ROPE, AS SPECIFIED BELOW, WITH THE PROPER BREAKING STRENGTHS LISTED.</li> <li>• ANTI-TWO-BLOCK SYSTEM MUST BE IN GOOD OPERATING CONDITION BEFORE OPERATING CRANE. SEE OPERATION &amp; SAFETY MANUAL.</li> </ul>
MAX PULL: 9,600 lbs	19,200 lbs	28,800 lbs	38,400 lbs	48,000 lbs	57,600 lbs	67,200 lbs	72,000 lbs	
MAX PULL: 9,060 lbs	18,120 lbs	27,180 lbs	36,240 lbs	45,300 lbs	54,360 lbs	63,420 lbs	72,000 lbs	9/16" - SPIN RESISTANT (5:1 S.F.) 45,300-lbs. BREAKING STRENGTH
CRANE MEETS ASME B30.5 REQUIREMENTS AT TIME OF MANUFACTURE								1214820 072216



Elliott Equipment Company  
3514 South 25th Street  
Omaha, NE 68105  
Phone: 402-592-4500  
Fax: 402-592-4553  
Email: sales@elliottequip.com

**Built for You.**  
www.elliottequip.com

**RANGE CHART - MAIN BOOM + JIB, FULL-SPAN OUTRIGGERS**



**MODEL 3600 142-FT BOOM**

RANGE DIAGRAM WITH FULL SPAN OUTRIGGERS

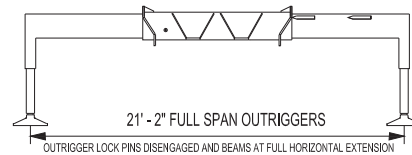
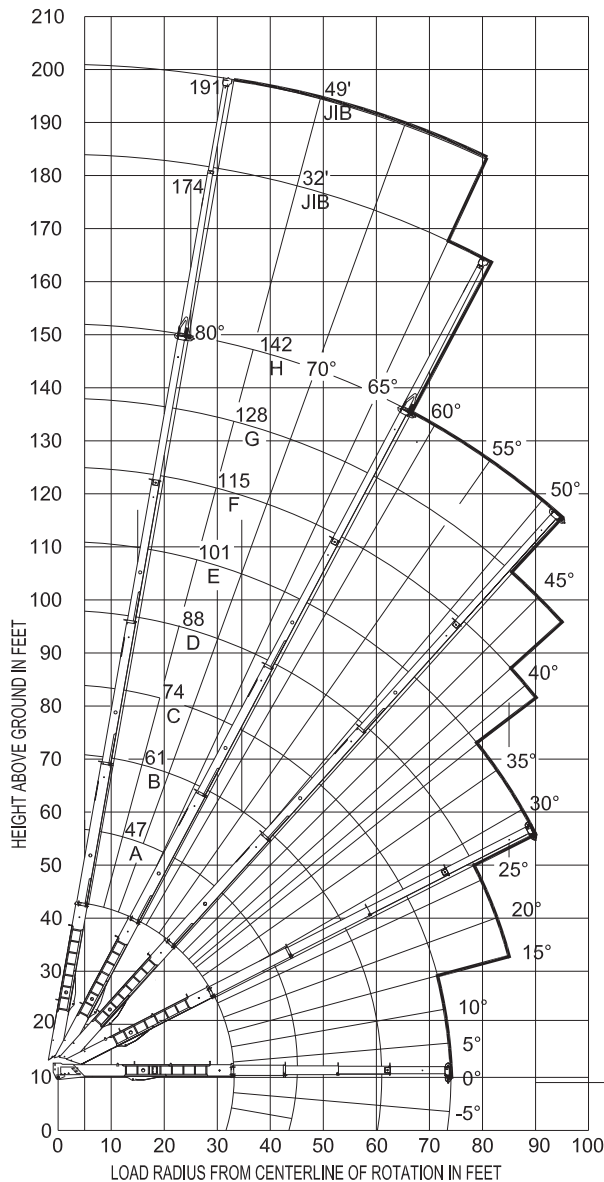

NOTE:

1. Operate jib by radius when main boom is fully extended. Increase boom angle if necessary to maintain load radius.
2. When boom is retracted, operate jib by boom angles. Do not exceed any rated jib capacities at reduced boom lengths.
3. Capacities do not exceed 85% stability.
4. Load ratings above bold line are structurally limited.
5. Personnel handling is allowed only with full span outriggers.
6. Boom load ratings are based on loaded boom radius. Loaded boom angles are given as reference only.

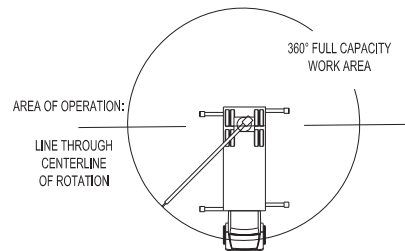

STABILITY LIMIT LINE (NO LOAD)

BOOM DEFLECTION NOT SHOWN

CRANE MEETS ASME B30.5 REQUIREMENTS AT TIME OF MANUFACTURE

1214820 072216

**RANGE CHART - MAIN BOOM + JIB, MID-SPAN OUTRIGGERS**



**MODEL 3600 142-FT BOOM**

RANGE DIAGRAM WITH OUTRIGGERS IN MID-SPAN POSITION

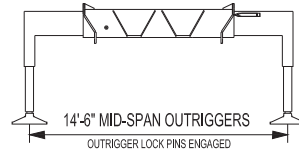
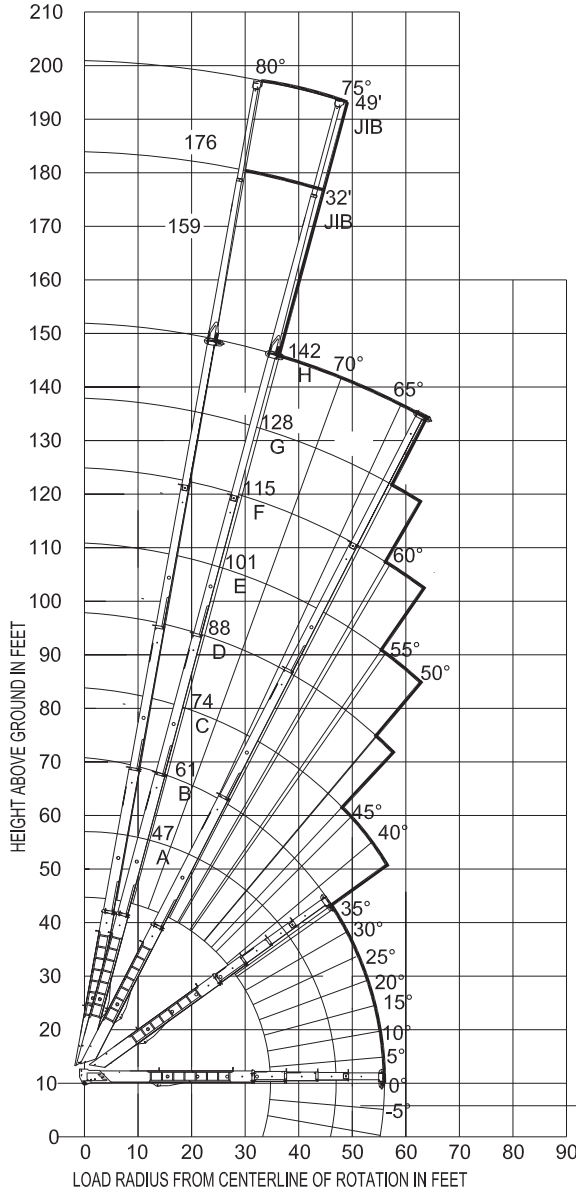

**NOTE:**

1. Operate jib by radius when main boom is fully extended. Increase boom angle if necessary to maintain load radius.
2. When boom is retracted, operate jib by boom angles. Do not exceed any rated jib capacities at reduced boom lengths.
3. Capacities do not exceed 85% stability.
4. Load ratings above bold line are structurally limited.
5. Personnel handling is allowed only with full span outriggers.
6. Boom load ratings are based on loaded boom radius. Loaded boom angles are given as reference only.

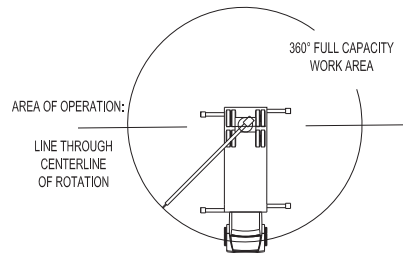

STABILITY LIMIT LINE (NO LOAD)

BOOM DEFLECTION NOT SHOWN

CRANE MEETS ASME B30.5 REQUIREMENTS AT TIME OF MANUFACTURE

1214820 072216

## RECOMMENDED CHASSIS SPECIFICATIONS

	36142 BoomTruck
Wheelbase (WB)	285" / 724 cm
Cab to Axle (CA)	219" / 556 cm
Cab to End of Frame (EOF)	344" / 874 cm
Frame Section Modulus	30.0 in <sup>3</sup> -110,000 psi / 492 cm <sup>3</sup> -758 MPa
Front Axle Gross Weight Rating	20,000 lb / 9072 kg
Rear Axle Gross Weight Rating	58,000 lb / 26 308 kg
Integral Front Frame Rails	Required for Front Stabilizer

Chassis data shows minimum general requirements-not for engineering.  
 Actual dimensions and truck data will depend on truck selection and axle configuration.  
 \*Minimum chassis weights are required to meet 85% stability requirements.

## OPTIONS



### Radio Remote Control

Interference protected radio remotes let you get closer to your work and have full control over your machine. Includes battery charging feature and optional LMI screen.

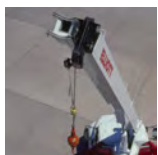

### Pin-On Jib Attachments

Two-piece telescoping jib with material handling and basket attachment capabilities. Stows on the side of the boom for transport to the jobsite.



### Hydraulic Oil Cooler

Add a hydraulic oil cooler to assist with high duty cycle job applications. Cooler activates automatically if the hydraulic oil temperature reaches a critical level.



### Automatic Safety Rotation Lockout

“Short-jack” your BoomTruck by adding an automatic safety lockout to prevent boom movement over the side where outriggers are not fully extended.



### Operator Cab

The enclosed steel operator cab includes an adjustable seat, windshield wipers, diesel heater, fan, and optional air conditioning.

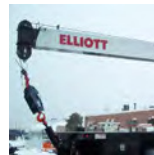

### Hook Block for Multi-Part Line

Choose from a range of available hook blocks for working with up to 8 parts of line. The block can be stored towards the front of the bed.



### 2-Man Yoke Work Platform

Elliott’s 600 lb capacity 2-man platform features a hydraulic yoke lifting system for easy attachment to the boom or jib tip. Fully OSHA compliant and heavy duty.

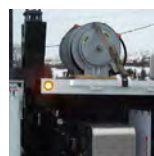

### Body Mounted Hose Reels and Circuits

Let us work with you to customize your tool compatibility by adding hose reels or hydraulic circuits to the crane bed.